

Installer manual

**By-alarm Plus burglar alarm system**

Installation Manual



**BY-ALARM PLUS**



## Index

<b>1. General characteristics</b> .....	4
1.1 Main components of the By-alarm Plus system .....	4
<b>2. How to create a system</b> .....	6
2.1 Off-line installation .....	6
2.2 On-site installation and routing of wired and radio peripherals/devices using the By-alarm Plus manager software .....	6
2.3 On-site installation and routing of wired peripherals without software .....	6
<b>3. The control unit</b> .....	7
3.1 Electrical and mechanical characteristics .....	7
3.2 Type of SD and current distribution .....	7
3.3 Maximum current output .....	8
3.4 System sizing criteria .....	9
3.5 Functional characteristics and manageable devices .....	11
3.6 Terminals and their use .....	11
3.7 Activity LEDs and what they mean .....	12
3.7.1 SERV/ENR LED .....	13
3.7.2 EXE LED .....	13
3.7.3 BUS LED .....	13
3.7.4 POWER LED .....	13
3.8 Push buttons .....	13
3.9 ATS categories .....	13
3.10 Voice synthesis card art. 03813 .....	13
3.11 Installing the control unit .....	14
3.12 Opening and closing the control unit .....	14
3.13 Connecting the PC .....	15
3.14 SERVICE/MAINTENANCE status .....	15
<b>4. Connecting the peripherals to the control unit bus</b> .....	16
4.1 Indications for terminals programmed as NO (norm. open) .....	17
<b>5. Connecting alarm sensors and balancing</b> .....	20
5.1 N.C./N.O. balancing .....	20
5.2 Single balancing .....	20
5.3 Double balancing .....	21
5.4 Triple balancing .....	21
5.5 Connecting roller shutter/inertia sensors and balancing .....	22
5.5.1 Roller shutter/inertia: normally closed (NC) .....	22
5.5.2 Roller shutter/inertia: single balancing (NC with EOL) .....	22
<b>6. Connecting sirens</b> .....	23
6.1 Connecting an outdoor siren and an indoor siren using a single relay .....	23
6.2 Connecting an outdoor siren and an indoor siren with separate control .....	24
6.3 Connecting an outdoor siren using “start” and “stop” and an indoor siren with separate control .....	25
6.4 Outdoor siren LED control .....	27
<b>7. Connecting outputs</b> .....	28
7.1 Auxiliary power supply terminals .....	28
7.2 Programmable, supervised auxiliary power supply terminals .....	28
7.3 Connecting open collector outputs .....	28
<b>8. Notifications</b> .....	29
<b>9. Routing peripherals</b> .....	30
<b>10. First power-up</b> .....	30
<b>11. Integration with the By-me Plus home automation system</b> .....	30
11.2 How to set up remote access using the View Pro App .....	30
11.2 Accessing the keypad as an Installer user .....	31
<b>12. Faults viewable on the keypad</b> .....	32
<b>13. Troubleshooting</b> .....	34

## General characteristics

### 1. General characteristics

The By-alarm Plus system is latest-generation hybrid burglar alarm system dedicated to protecting people and property from unauthorised access. It comprises a set of wired devices/peripherals (connected to the system by BUS) and a set of via-radio devices/peripherals.

The system stands out due to the following features:

- modular
- contextual
- flexible

#### Modular

A By-alarm Plus system is created by using solely the devices required for the needs of the end user. No peripheral is compulsory, the functions with greatest added value can be implemented by purchasing devices only where required and the system is expandable according to installation requirements. For instance, a system without keyboards can be created, even though this entails certain restrictions. The radio frequency part, which is also optional, comprises transceivers connected to the control unit via BUS and signal repeaters; the latter are used to extend the range of “coverage” and are connected via radio to the reference transceiver.

#### Contextual

Using the By-alarm Plus Manager programming software, the installer can only operate on the system elements that they are actually using, avoiding the display/editing of parameters or unnecessary functions. For instance, if the system envisages the use of 2 areas, the installer will be able to see and programme all the parameters consistent with just the 2 areas used even though the control unit manages 10 of them. When configuring a specific type of detector, the software shows the installer only those parameters and options that are consistent with the chosen article since it analyses the context and hides/shows only the parameters of interest.

For the end user the benefits are the same: a keypad will present the user with only those controls actually consistent with the current status of the system. If for instance all the areas are disabled, the keypad will never have a control available for disabling.

#### Flexible

The system operates in the same way as a PLC which activates, deactivates, enables, disables, notifies events and statuses that the control unit detects and all the interactions are programmable. The via-radio part, which is also completely optional, is managed with the same criteria, procedures and functions as wired peripherals/devices in order to standardise the interfaces for the installer and user. In addition to the classic functions of a burglar alarm system, it is for instance possible to create a simple access control, or to generate interlinked automations and it is also possible to set automatic activations/disconnections that the user can edit at their discretion. With the appropriate authorisations, a user can also create new users (operation usually permitted only for the installer in current burglar alarm systems).

#### 1.1 Main components of the By-alarm Plus system

- **Control unit**

It identifies the central processing unit. It consists of the main card, available in 3 versions and this component is necessary for the operation of the By-alarm Plus system.

- **BUS**

It is a communication channel consisting of a normal cable with 4 conductors, 2 for the power supply and 2 for data transfer. Each device (also referred to as a peripheral) can be connected to the BUS in star configuration without the need for end-of-line resistors; this makes it extremely easy to use since a peripheral can be connected wherever a BUS cable is present without the need to make in-out connections.

- **By-alarm Plus Manager Software**

This is the software intended for the installer on Microsoft PC. It is designed to configure the system, set all the parameters, save all the systems created and perform complete monitoring of the system to display, in dedicated sections, the status of peripherals, areas, detectors, outputs, battery levels, radio signal levels, voltages and absorptions.

- **Peripherals**

It identifies the various elements that can be connected to the control unit which allow the running of various functions, specific to each type of peripheral. They are connected to the control unit via BUS. The system allows the routing of each peripheral, both using the By-alarm Plus Manager software as well as using a procedure on the control unit, in order to assign it to the system configuration. Each peripheral has a unique QR-code in order to detect any unauthorised replacements. The peripherals which can be connected to the control unit via BUS are as follows:

- LCD keyboards
- Actuators
- Expansions
- LTE communicator
- Sirens
- Transceivers
- BUS isolators

- **LCD keyboards**

They are distinguished by an LCD graphic display, 5 signalling LEDs, a keypad and other parts which differ depending on the type of keyboard. Thanks to the display, LEDs and keypad, the user can completely control the system, observing its status and operating all the controls. The articles are:

- LCD keypad art. 03817
- LCD keypad with actuator and 2 I/O terminals art. 03818

- **Actuators**

They are equipped with 4 LEDs to display certain system statuses and to perform control operations. Using the transponder keys and with the aid of the LEDs, the user is in a position to select the control to send to the system. The art. is:

- Actuator art. 03824

- **Expansions**

These are peripherals with 5 completely programmable I/O terminals which can be connected to detectors (zones) and actuators (outputs). The articles are:

- Expansion in open enclosure art. 03808
- Expansion in closed enclosure art. 03819

## General characteristics

### • LTE communicators

They notify users and installers of system events via the mobile network operators. They operate in the 2G, 3G and 4G networks that the peripheral automatically selects (according to the best technology available in the location of the system installation) and send voice messages and text messages. The user may also send text messages to the peripheral to give the system controls. The articles are:

- LTE communicator art. 03810
- LTE communicator with buffer batteries art. 03820

### • Sirens

They carry out the optical-acoustic signalling generated by burglary events. They are equipped with piezoelectric elements that generate high sound power and have an illuminator/flashing lamp with high-efficiency LEDs. The articles are:

- BUS outdoor siren art. 03826
- Outdoor siren art. 03827
- Radio outdoor siren art. 03830

### • Radio interfaces

They are devices on BUS which allow the structure of the system to be extended using via-radio communications between various elements (detectors, remote controls, sirens). They operate in the dedicated frequency band centred on 868 MHz. The articles are:

- Transceiver in plastic enclosure art. 03831
- Transceiver on plastic bracket art. 03832

### • BUS isolators

They carry out the regeneration of BUS signals and allow the galvanic isolation between two BUS sections. It is the only peripheral for which the connection to the BUS occurs on 4 terminals dedicated to the incoming BUS and on another 4 terminals dedicated to the outgoing BUS. The articles are:

- Isolator art. 03822
- Isolator with 12V@1A power supply unit art. 03823

### RADIO FREQUENCY DEVICES

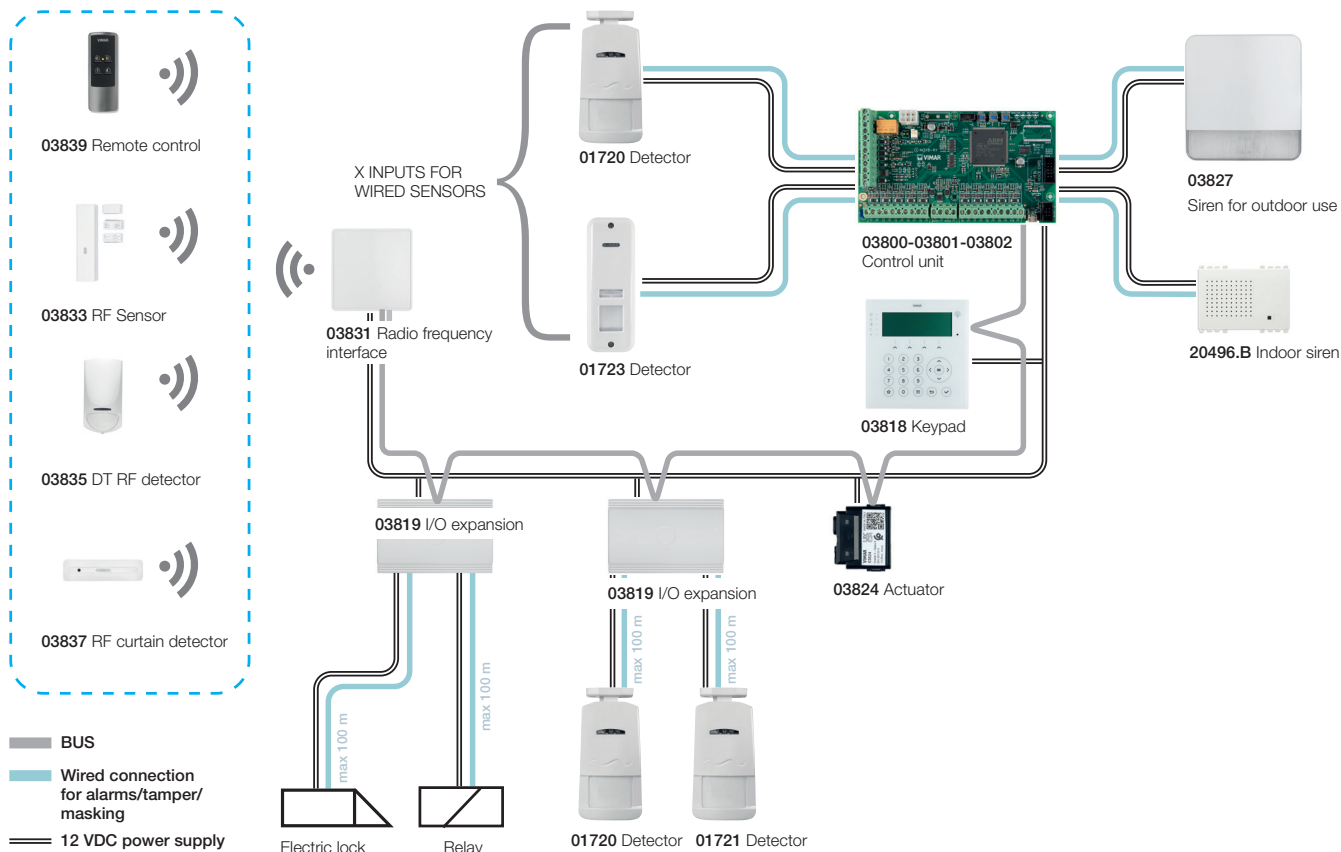

## How to create a system

### 2. How to create a system

Below is a description of the different ways a By-alarm Plus system can be created. In actual fact each method is not mutually exclusive from the next and so the installer will decide the most appropriate one to use.

**IMPORTANT: The By-alarm Plus Manager programming software is always indispensable.**

**CAUTION: The default PIN for the installer, which is necessary to access via the keypad or the software, is 9999.**

#### 2.1 Off-line installation

In this mode, after performing the appropriate surveys at the system installation site, the installer performs the entire configuration of the system on a bench using the software and so without the need to power the elements/peripherals/devices. The procedure is as follows:

1. The installer has everything they need, all the packs and the Qr-codes of all peripherals/devices
  2. None of the devices has been installed, all the peripherals/devices are on the bench
  3. Open the By-alarm Plus Manager software and create a new system
  4. Perform the configuration of all the wired peripherals using the QR-codes
  5. Where present, perform the configuration of all devices radio using the QR-codes
  6. Set the parameters for the whole system and save it in the PC, assigning it a name
  7. Perform the installation (fixings and wiring) of the control unit and of the peripherals/devices in the site the system is to be created in
  8. Power up the system
  9. Send the system created previously and saved in the software to the control unit.
- The system is now up and running.

#### 2.2 On-site installation and routing of wired and radio peripherals/devices using the By-alarm Plus manager software

In this mode, the installer has already installed (fixed and wired) all the peripherals/devices in the installation site. The procedure is as follows:

- 1) During installation of the wired peripherals on BUS and of the via-radio devices, keep all the Qr-codes and identify their respective position in the system (for instance, the keypad with QR-code **2C40000236F032** is the one at the entrance; the magnetic contact with QR-code **R03000AKB6F035** is the one for the kitchen window, etc.)
  - 2) Power up the system
  - 3) Open the By-alarm Plus Manager software and create a new system
  - 4) Use the QR-codes of each peripheral on BUS to assign it to the system
  - 5) Where present, use the QR-codes of each via-radio device to assign it to the system
  - 6) Use the software to set the parameters for the entire system and, as they are gradually defined, send them to the control unit
  - 7) When programming is complete, save the system in the PC and assign it a name
- The system is now up and running.

#### 2.3 On-site installation and routing of wired peripherals without software

In this mode, the installer has already installed (fixed and wired) all the peripherals/devices in the installation site.

Consider that the By-alarm Plus Manager software will still be necessary to complete the configuration of the entire system. The procedure described herein only performs rapid routing of the peripherals on BUS using push buttons and LEDs present on the control unit card.

The procedure is as follows:

- 1) During installation of the wired peripherals on BUS, keep all the QR-codes and identify their respective position in the system (for instance the keypad with QR-code **2C40000236F032** is the one installed at the entrance, etc.)
  - 2) Power up the system
  - 3) Go to the control unit and set it to ENROL status (device routing phase start): press and hold down (approximately 2 s) the SERV/ENR push button until the corresponding red SERV/ENR LED starts flashing
  - 4) In sequence, press the ENROL push button on each expansion (art. 03808 or 03819)
  - 5) In sequence, approach a transponder key to each actuator (art. 03824)
  - 6) In sequence, press the ENROL button on each keypad (art. 03817 or 03818)
  - 7) Press the ENROL button on the transceiver (art. 03831)
  - 8) In sequence, press the ENROL button on each BUS siren (art. 03826)
  - 9) At the end, briefly press the SERV/ENR push button on the control unit to exit the routing phase
    - i) N.B. Points **4**) to **8**) do not necessarily need to be performed in sequence; the operation described can be performed using any peripheral, for instance by pressing the ENROL push button on an expansion, then the ENROL button on a keypad, then the ENROL push button on a siren and so on.
    - ii) The peripherals are acquired by the control unit and routed via a progressive number (1, 2, 3, etc.) depending on how the installer performs the sequence.
    - iii) Keep in mind that each type of peripheral is routed starting with index 1 (so it is possible for you to have a keypad, an expansion, a siren and an actuator at the same logical address, but it is not possible for you to have two keypads at the same logical address).
  - 10) Open the By-alarm Plus Manager software and perform a system reading in order to transfer the programming stored in the control unit to the PC
  - 11) Since you marked the physical position of the peripherals, assign a description/label to each peripheral using the software
  - 12) Use the software to set the parameters for the entire system and, as they are gradually defined, send them to the control unit
  - 13) When programming is complete, save the system in the PC and assign it a name
- The system is now up and running.

## The control unit

### 3. The control unit

The microcontroller-based control unit, available in versions with 25, 65 and 125 zones (art. 03800, 03801 and 03802, respectively) has 10 expandable input/output lines and is managed through the LCD keypad art. 03817 and 03818 with actuator 03824; it has 1 programmable relay, 2 open-collector outputs and 3 auxiliary 12 V outputs. The voice synthesis card 03813 and the GSM transceiver module 03810-03820 can be connected to the control unit. The system is programmed via the By-alarm Plus Manager software running on the PC.

The tables below display the main characteristics of the three types of control unit.

#### 3.1 Electrical and mechanical characteristics

Control unit		03800	03801	03802
Voltage	power supply	230 V~ -15% +10% 50/60 Hz		
	rated output	13.8V ± 1%		
Maximum	absorption	<ul style="list-style-type: none"> <li>• 0.5 A @ 230 V~ with power supply unit 03805</li> <li>• 1.1 A @ 230 V~ with power supply unit 03806</li> </ul>		
	of control unit card	50 mA @ 13.8 V		
Installation		<ul style="list-style-type: none"> <li>• In plastic box art. 03814</li> <li>• In metal box art. 03815;</li> <li>• In control unit adapter box art. 03816 (**).</li> </ul>		
Failure voltage at the power supply outputs		9.8 V		
Protection trigger voltage	against deep discharges	9.5 V		
	against voltage surges	15.4 V		
Maximum ripple on supply voltage		140 mV		
Type of PS		A		
Maximum current on BUS		4A		
Type of alarm notification (EN 50131-1)		D (*)		
IP protection degree		30		
Safety class	EN50131-3	3		
	EN50131-6	3		

(\*) Notification types A, B and C are also possible according to the configuration of the control unit and system.

(\*\*) This configuration cannot be certified.

#### 3.2 Type of SD and current distribution

Control unit		03800	03801	03802
Type of SD (buffer battery)	rated voltage	12 V		
	maximum capacity	<ul style="list-style-type: none"> <li>• 7 Ah for plastic enclosure 03814</li> <li>• 7 Ah or 18 Ah for metal enclosure 03815</li> </ul>		
	maximum charge time	<ul style="list-style-type: none"> <li>• 4.7 h for 80% charge on 7 Ah battery</li> <li>• 12 h for 80% charge on 18 Ah battery</li> </ul>		
	maximum internal resistor (Ri max)	<ul style="list-style-type: none"> <li>• 2.7 Ω with power supply unit 03805</li> <li>• 1 Ω with power supply unit 03806</li> </ul>		
	low battery voltage	11 V		
	battery reset voltage	12 V		
Maximum delivery current @ 12V	Total	<ul style="list-style-type: none"> <li>• 3.2 A for plastic enclosure 03814 and power supply unit 03805</li> <li>• 3.2 A or 6.2 A for metal enclosure 03815 and power supply units 03805 or 03806</li> </ul>		
	For battery charge	1.2A		
Maximum current available on each +AUX terminal		1.5 A		
Maximum current delivered on the open collector outputs	T1, ..., T10	250 mA		
	OC1, OC2	500 mA		
Maximum delivery current		350 mA		

(a) The range of the system in the absence of the primary power source can be limited to 30h for a system with a degree of safety of 3 or 4, if an alarms reception centre or another remote centre is notified of a primary power source failure.

(b) If the system is decreased to degree 2, the range may be limited to 12h.

(c) For type A or B power supply units, if the system includes an additional primary power source with automatic switching between the primary power source and the additional primary power source, the range may be limited to 4h irrespective of the degree of safety of the system.

## The control unit

### 3.3 Maximum current output

Grade 2 Systems (12 h range)	
Load distribution with power supply unit 03805	Load distribution with power supply unit 03806
<ul style="list-style-type: none"> <li>• 0.05 A for self-consumption of the card</li> <li>• 1.2 A to charge the battery</li> <li>• 0.53 A for outdoor devices (7 Ah battery)</li> <li>• 1.45 A for outdoor devices (18 Ah battery)</li> </ul>	<ul style="list-style-type: none"> <li>• 0.05 A for self-consumption of the card</li> <li>• 1.2 A to charge the battery</li> <li>• 1.45 A for outdoor devices (18 Ah battery)</li> </ul>

Grade 3 Systems (30 h range)	
Load distribution with power supply unit 03805	Load distribution with power supply unit 03806
<ul style="list-style-type: none"> <li>• 0.05 A for self-consumption of the card</li> <li>• 1.2 A to charge the battery</li> <li>• 0.19 A for outdoor devices (7 Ah battery)</li> <li>• 0.55 A for outdoor devices (18 Ah battery)</li> </ul>	<ul style="list-style-type: none"> <li>• 0.05 A for self-consumption of the card</li> <li>• 1.2 A to charge the battery</li> <li>• 0.55 A for outdoor devices (18 Ah battery)</li> </ul>

Systems with 4 h range	
Load distribution with power supply unit 03805	Load distribution with power supply unit 03806
<ul style="list-style-type: none"> <li>• 0.05 A for self-consumption of the card</li> <li>• 1.2 A to charge the battery</li> <li>• 1.7 A for outdoor devices (7 Ah battery)</li> <li>• 1.95 A for outdoor devices (18 Ah battery)</li> </ul>	<ul style="list-style-type: none"> <li>• 0.05 A for self-consumption of the card</li> <li>• 1.2 A to charge the battery</li> <li>• 4.45 A for outdoor devices (18 Ah battery)</li> </ul>



## The control unit

### 3.4 System sizing criteria

This paragraph illustrates the flow diagram with the criteria to follow for the correct sizing of the system in relation to the desired range and to the consumption levels of the devices in the By-alarm Plus system.

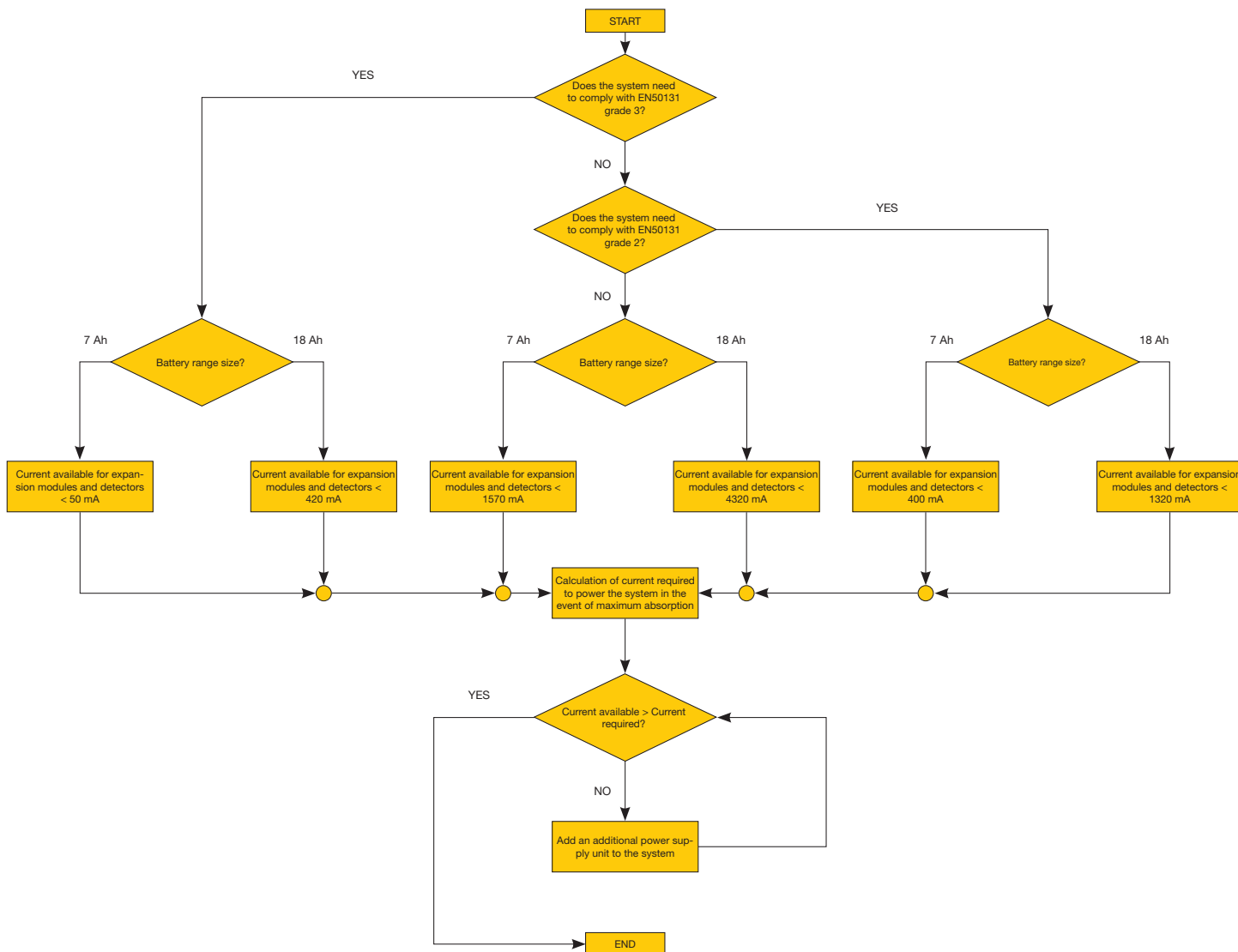

**CAUTION:** For the correct sizing of the system, always consider the maximum consumption condition; this condition varies according to the number of devices present in the system and to the configuration created.

Generally speaking, we recommend you pay attention to the condition of total enabling and the active alarm condition.

## The control unit

### Devices in the By-alarm Plus system and their consumption levels

Article	Description	Notes	Absorption
03808	5 In/Out expansion card		20 mA
03809	Relay interface card		30 mA
03810	GSM 4G communicator card	In transmission	540 mA
		Stand-by	70 mA
03813	Voice synthesis card		10 mA
03817	Keypad with display	Active display	80 mA
		Stand-by	20 mA
03818	Keypad with display and transponder	Active display	115 mA
		Stand-by	35 mA
03819	5 In/Out expansion		20 mA
03820	GSM 4G communicator	In transmission	540 mA
		Stand-by	70 mA
03822	BUS isolator		110 mA
03823	BUS isolator with power supply unit		130 mA
03824	1M flush mounting actuator	Key present	50 mA
		Key absent	20 mA
03826	BUS outdoor siren	Internal battery charging	150 mA
		Stand-by	20 mA
03827	Outdoor siren	Internal battery charging	150 mA
		Stand-by	20 mA
03831	Surface mounting RF interface (in closed plastic enclosure)		20 mA
03832	Surface mounting RF interface (on plastic bracket)		20 mA
03840	Radio signal repeater		30 mA
01720	Dual technology detector, anti-masking detection, PET immune	Max	40 mA
		Stand-by	30 mA
01721	Dual technology detector, anti-masking and anti-crawl detection	Max	40 mA
		Stand-by	30 mA
01722	Dual technology curtain detector	Max	40 mA
		Stand-by	-
01723	Dual technology IP54 outdoor curtain detector	Max	70 mA
		Stand-by	60 mA
01739	PET immune IP55 IR detector	Normal operation	28 mA
		Max	38 mA
01740	PET immune curtain IR detector		20 mA
30529-20479 19479-14479	By-alarm passive infrared and microwave presence detector	Max	28 mA
		Stand-by	15 mA
30526-20496 19496-14496	By-alarm siren for indoor use	In an alarm condition	110 mA
		Stand-by	18 mA

## The control unit

### 3.5 Functional characteristics and manageable devices

Control unit	03800	03801	03802
Areas	5	10	20
Total zones	25	65	125
Keyboards		20	
Expansions		50	
Readers		20	
BUS sirens		5	
Radio sirens		4	
Radio transceivers		1	
Radio repeaters		4	
Isolators		6	
GSM/LTE communicator		1	
User profiles		25	
Users	50	100	200
Possible user PIN combinations		1000000	
Electronic keys/remote controls	100	200	400
Possible key combinations		4294967296	
Possible remote control combinations		16777216	
Weekly automations		10	
Recordable events		10000	

### 3.6 Terminals and their use

Control unit	03800	03801	03802
Total terminals	25	65	125
Terminals in control unit	in total	10	
	for configuration as inputs	10	
	for configuration as roller shutters/ inertia	10	
	for configuration as outputs	10	
Terminals via radio	25	65	125
Terminals in the keyboards (art. 03818)		2 for each keypad	
Terminals in the expansions		5 for each expansion	
Outputs in the control unit	in total	16	
	Terminals T1, T10	10	
	relay	1	
	open collector (OC1, OC2)	2	
	auxiliary outputs (AUX1, AUX2, AUX3)	3	

#### CAUTION!

Do not tamper with or disconnect the cables as they are factory set. If the installer needs to replace one of the parts (for maintenance or repairs), we recommend these cables only be connected or disconnected once both the AC mains voltage and the battery have been disconnected.

## The control unit

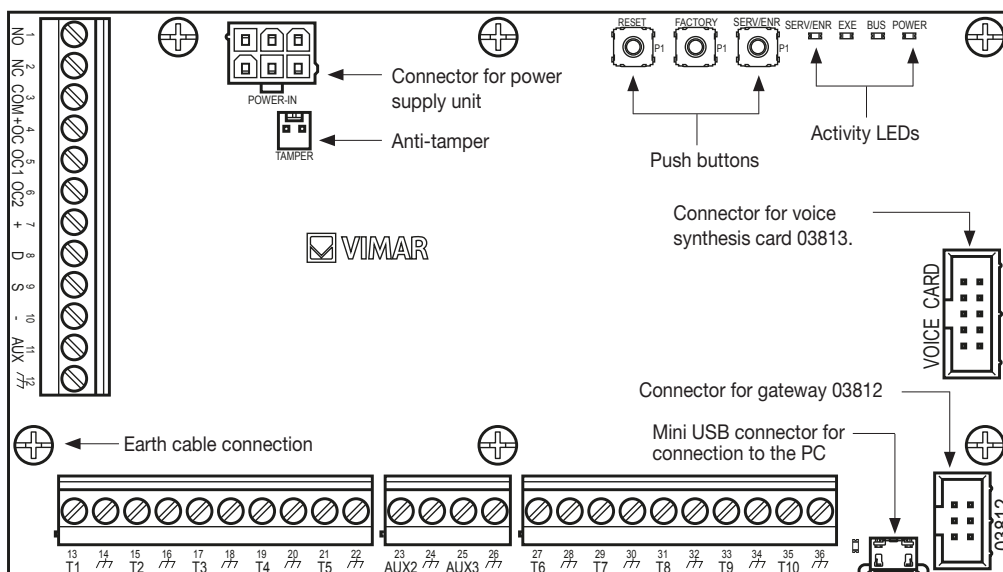

Terminal no.	Name	Function
1 - 2 - 3	NO NC COM	Relay volt-free changeover outputs
4	+OC	Auxiliary power supply - 13.8 V
5 - 6	OC1 OC2	Open Collector outputs
7 - 8 - 9 - 10	+ D S -	I-BUS connection
11 - 23 - 25	AUX1 AUX2 AUX3	Output terminals - 13.8V
12 - 14 - 16 - 18 - 20 - 22 - 24 - 26 - 28 - 30 - 32 - 34 - 36	⌚	Power supply negative (earth/GND)
13 - 15 - 17 - 19 - 21 - 27 - 29 - 31 - 33 - 35	T1-T2-T3-T4-T5-T6-T7-T8-T9-T10	Control unit input/output terminals

EN IEC 62368-1 table

Insulation class	I	
Type of terminals	AC input	ES3, PS3
	BAT-, BAT+	ES1, PS2
	+ D S -	ES1, PS2
	AUXn, +12V	ES1, PS2
	NO, NC, COM	ES1, PS2
	Tn, OCn	ES1, PS1
	OUTn (Flex5/R, Flex2R/2T)	ES3, PS3
	Cn, NO <sub>n</sub> , NC <sub>n</sub> (AUXREL32)	ES1, PS2
USB	ES1, PS1	

### 3.7 Activity LEDs and what they mean

The LEDs present on the control unit card provide information about the correct operation of the control unit and of the BUS.

LED	Colour	Indication	
SERV/ENR	Red	ON OFF FLASHING	= control unit under MAINTENANCE (**) = control unit operating = control unit performing peripheral learning
EXE	Blue	ON or OFF PULSING FLASHING	= control unit in abnormal blockage (*). Ask for assistance! = control unit operating = firmware update in progress
BUS	Yellow	OFF FLASHING	= no peripheral on BUS = BUS operating or waiting for peripheral learning
POWER	Green	ON OFF	= mains voltage on = no mains voltage

PULSING: the brightness varies gradually from OFF to ON and vice-versa.

FLASHING: the brightness switches neatly from ON to OFF and vice-versa without gradual changes.

## The control unit

### 3.7.1 SERV/ENR LED

The red LED indicates the following phases:

**on steady** = control unit under MAINTENANCE (\*\*, see the paragraph concerning the MAINTENANCE status hereunder); certain functions are forbidden, such as the processing of alarms and sabotages

**off** = control unit fully operating normally, all the processing is active

**flashing** = control unit in peripheral on BUS acquisition phase; the control unit waits for the installer to perform the enrolment procedure of keyboards, actuators, expansions, etc. which are connected to the BUS.

### 3.7.2 EXE LED

During normal control unit operation, the LED flashes blue, increasing and decreasing its brightness progressively. When exiting the installer menu or at the end of programming from a PC or during the factory resetting or during firmware reprogramming of the control unit and peripherals, the LED may take on the steady ON or OFF status for the duration of the operation in progress, at the end of which it should start to flash again. (\*) The LED on or off outside the above-mentioned situations is an indication of a blockage in the running of all the control unit functions (ask for assistance!).

### 3.7.3 BUS LED

During normal control unit operation and if the system has at least one peripheral on BUS, the LED flashes yellow irregularly, not periodically. When exiting the installer menu or at the end of programming from a PC or during the factory resetting or during firmware reprogramming of the control unit and peripherals, the LED may take on the steady ON or OFF status for the duration of the operation in progress, at the end of which it should start to flash again. If the system is completely devoid of peripherals on the BUS, the LED takes on the OFF status; this condition outside the above-mentioned situations is an indication of the blockage of the BUS, which can be confirmed by verifying the loss of interactivity with readers, expansions or keyboards.

### 3.7.4 POWER LED

The lit LED indicates the presence of the power supply. If the LED is off, the primary power supply is missing; the control unit will continue to operate until the flat battery disconnection threshold (9.5V) is reached.

## 3.8 Push buttons

The following push buttons are present on the control unit card:

- RESET to reset the control unit and restore the factory settings
- FACTORY to reset the control unit and restore the factory settings
- SERV/ENR to launch the learning phase

## 3.9 ATS categories

The By-alarm Plus controls constitute, either individually or in combination with devices/peripherals, an SPT (Supervised Premises Transceiver) usable to create an ATS (Alarm Transmission System) according to the definitions set out in standards EN 50136-1 and EN 50136-2.

The maximum categories of ATS achievable with the SPT configurations and the main communication channel used and the respective parameters are shown in the following table.

ATS category	Transmission time		Relation time	Safety in replacement	Safety in information	Operating mode	
	Classification	Maximum values					
Single Path	2	D2 (60s)	M2 (120s)	T2 (25h)	S0	I0	Pass-through
	6	D4 (10s)	M4 (20s)	T6 (20s)	S2	I3	
Dual Path	2	D3 (20s)	M3 (60s)	T3a (30min)	S0	I0	
	4	D4 (10s)	M4 (20s)	T5 (90s)	S2	I3	

## 3.10 Voice synthesis card art. 03813

This is an optional card and is only necessary if voice functions are required to send voice messages via phone calls.

The voice card is supplied with xxx pre-recorded messages. These messages are transmitted via vocal calls associated with the event which should each time occur.

To install the card, proceed as follows:

1. Cut off the power supply to the control unit by disconnecting both the lead battery and the primary power source.
2. Connect the card to the VOICE CARD connector on the control unit.
3. Power the control unit by first connecting the primary power source and then reconnecting the lead battery.

## The control unit

### 3.11 Installing the control unit

The control unit card can be installed together with other peripherals inside the following articles:

- Art. 03814  
By-alarm Plus plastic box for 25- or 65-zone control unit card, 2 slots available for 5 In/Out expansion card 03808, GSM communicator card 03810 or burglar alarm system gateway 03812, 1 slot available for radio module 03832, 1 3.2A power supply unit 03805, 1 housing for 7Ah battery, anti-removal and anti-tamper protection, surface mounting.
- Art. 03815  
By-alarm Plus metal box for 25-, 65- or 125-zone control unit card, 4 slots available for 5 In/Out expansion card 03808, GSM communicator card 03810 or burglar alarm system gateway 03812, 1 slot available for radio module 03832, 1 3.2A power supply unit 03805 (6.2 A 03806 for 125 zones), 1 housing for 7Ah battery (17Ah for 125 zones), anti-removal and anti-tamper protection, surface mounting.
- Art. 03816  
Adaptor mounting box for By-alarm Plus 24-module switchboard for 25-65 zone card, 3 slots for 5 In/Out expansion card 03808, GSM communicator card 03810 or burglar alarm system gateway 03812, 1 slot available for radio module 03832, 1 3.2A power supply 03805, 1 housing for 7Ah battery, anti-removal and anti-tamper, surface mounting.

All the details can be found in the instruction sheets for the above articles.

A separate line from the electrical distribution board is needed to power the control unit. This line must be protected by disconnection and protection devices.

**CAUTION: Take great care when connecting the primary source. Electric shock hazard.**

Install the disconnection device in an easily accessible place outside the equipment. The gap between contacts must be at least 3 mm. The recommended disconnection device is a circuit breaker with a C trip curve and maximum rated current of 16 A.

The site earthing system must comply with the current regulations.

1. Route the power supply cables through the cable outlet hole.
2. Connect the mains power supply to the corresponding terminals. To comply with the safety standards, the phase conductor must be connected to the “L” terminal and the neutral conductor must be connected to the “N” terminal.
3. Ensure that safety extra-low voltage or signal conductors cannot touch points at hazardous voltages. Use a cable tie to secure the conductors together and fasten them securely to one of the cable hooks on the bottom of the cabinet.  
**N.B.:** Do not strengthen the ends of stranded conductors with soft soldering at the points in which they are subject to contact pressure.
4. Crimp the earth conductor to the ring terminal provided.
5. Secure the cable with the ring terminal to the earthing stud using the nut provided.

#### Connecting the buffer battery

The plastic enclosure can house a 12V 7Ah lead battery (not provided).

Take great care to observe the battery polarity:

- black cable = negative
- red cable = positive

For the battery connection, use the dedicated connection cable supplied with the control unit card.

Connect the cable to the control unit through the corresponding connector on the power supply unit.

#### CAUTION!

The control unit recharges and supervises the status of the buffer battery. The battery efficiency is controlled by dedicated tests every 4 minutes. In the event that the battery is not efficient, in other words the control unit detects a voltage below 10.4V, the “Flat Battery” event is generated, which is restored in the event that the voltage exceeds 11.4V. In this case the yellow LED on the keyboards will light up. To display the failure on the keyboard display, press the *info* button, which will become available

#### Temperature probe

A temperature probe is available to adjust the battery charging voltage to compensate its temperature. Using this probe prevents the battery from overheating, which would damage it.

To connect the temperature probe, proceed as follows:

- Disconnect the battery.
- Connect the temperature probe to the connector on the power supply unit
- Secure the temperature probe to the battery in such a way as to ensure good heat transfer.

### 3.12 Opening and closing the control unit

To gain access to the control unit, proceed as follows:

- On a keypad, long press push button , enter the PIN and press OK: access to the installer menu prevents activation of the outputs and any notifications programmed in correspondence with the control unit opening.
- Open the cover on the enclosure or remove it.
- Perform any maintenance/other work
- Close the cover.
- Exit the installer menu.

## The control unit

---

### 3.13 Connecting the PC

This can be done in the following ways:

- **USB:** this is a direct connection to the control unit via the USB port.  
The connection operation depends on the installation of the drivers for communication via USB which are normally available on PCs where Microsoft® Windows® is installed.
- **LAN networks:** this type of connection occurs via the gateway art. 03812.  
Communication operation depends on the configuration of the network itself. You should therefore check with the network administrator.  
Refer to the By-alarm Plus Manager software manual for connection details.

### 3.14 SERVICE/MAINTENANCE status

The **SERVICE/MAINTENANCE** status is used during the system configuration phases. When the control unit is in SERVICE/MAINTENANCE mode, it is completely operational with the exception of the following functions:

- all the outputs and the recording of events activated in correspondence with the events listed below are forced to standby and, in the presence of such events, will not be activated;
  - alarm or zone and area sabotage
  - peripheral sabotage
  - control unit removal/tampering sabotage

To set the control unit to SERVICE/MAINTENANCE status, briefly press the SERV/ENR push button; the corresponding red LED will light up.

To exit the SERVICE/MAINTENANCE status, briefly press the SERV/ENR push button again; the corresponding red LED will turn off.

## Connecting the peripherals to the control unit bus

### 4. Connecting the peripherals to the control unit bus

Connection of peripherals to the control unit is with a 4-wire (or more) shielded cable.

**Caution:** Connect the shield to one of the earth (or GND) terminals at the control unit end only, and ensure that it follows the entire BUS without being connected to earth at any other point.

Connection to the BUS is done on the "+ D S -" terminals present on the peripherals.

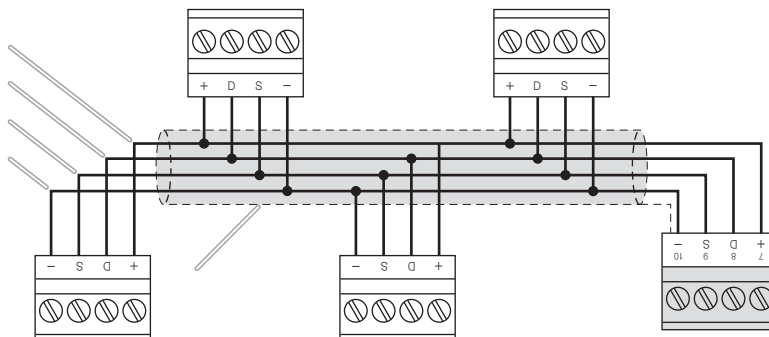

The sizing of the BUS line, in other words the distribution of the peripherals and the use of cables to connect them, should be done according to various design factors, in order to guarantee the correct transmission of signals of the "D" and "S" conductors and of the power supply provided by the "+" and "-" conductors.

These factors are:

- The current absorption of the connected devices.

In the event of insufficient power supply from the BUS line to the peripherals and sensors, it can also be provided by external power supply units.

- Type of cables.
- Speed of communication on the BUS.

This parameter can be set using the By-alarm Plus Manager software. The communication speeds are: 125kbs, 250kbs.

- Number and distribution of isolators (art.03822, 03823).

To increase the reliability and extension of the BUS, you need to use isolator devices.

The section of the cables used affects the dispersion of the conductor signals.

#### Recommended cables

CEI 20-22 II AF cable	no. of conductors	Section (mm <sup>2</sup> )	IBUS terminal
Cable with 4 conductors + shield + sheath	2	0.5	+ -
	2	0.22	D S
Cable with 6 conductors + shield + sheath	2	0.5	+ -
	2	0.22	D S
	2	0.22	available
Cable with 6 conductors + shield + sheath	2	0.75	+ -
	2	0.22	D S
	2	0.22	available

#### BUS sizing

BUS speed	Maximum length of the BUS
125kpbs	600m
250kpbs	300m

For correct isolator installation, the branch of the BUS where the isolator is located needs to be sized according to the number of peripherals connected to this branch and to their total current absorption. This absorption should therefore be compared to the "Maximum control unit absorption" value.

Another characteristic to take into account is the line length downstream of the isolator up to the next isolator or to the end of the line. The table below shows the indicative values of this length in relation to the BUS speed

#### Sizing of isolators 03822, 03823

BUS speed	Cable length downstream of the isolator (L)	Maximum number of cascaded isolators
125kpbs	350m	6
250kpbs	200m	2



## Connecting the peripherals to the control unit bus

The length (L) indicated here corresponds:

- in the case of a single line, to the length of the cables between an isolator and the subsequent peripherals or between two subsequent isolators.
- in the case of branched lines, to the sum of the lengths of all lines between an isolator and the subsequent isolators or that end with peripherals.

The figure below illustrates a sample system with BUS speed of 125kbps.

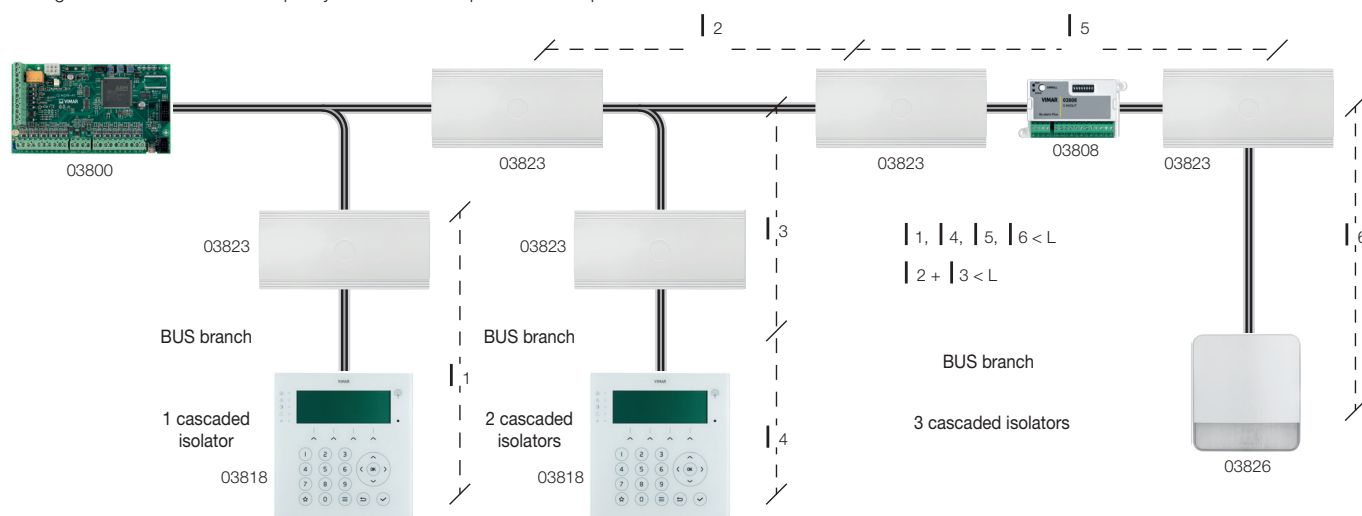

### Note

The distances indicated in the tables are obtained in optimum wiring conditions and respecting the above-mentioned points. We recommend fitting an isolator immediately after the control unit. Fit each isolator at a point where the BUS transmission quality is reduced.

### 4.1 Indications for terminals programmed as NO (normally open).

Terminal	Status	Terminal electric status	Current limit	Voltage limit	Notes
OC1 OC2	ON	GND	500 mA	13.8 V	-
	OFF	Open (i.e. disconnected)			
+AUX1 +AUX2 +AUX3	ON	+13.8	1.5 A	13.8 V	-
	OFF	float			
T	ON	GND	250 mA	13.8 V	Internal 120kΩ pull-up
	OFF	12 V (high impedance)			

T means terminals:

- T1, T2,.....T10 of the control unit (art. 03800, 03801 and 03802)
- T1, T2,.....T5 of the expansions (art. 03808 and 03819)
- T1 and T2 of the keypad with transponder (art. 03818).

## Connecting the peripherals to the control unit bus

### 4.2 Connecting isolators

The isolators have a dual purpose:

- to regenerate the electrical signals of the BUS which deteriorate in the presence of long sections or in the presence of multiple connected devices;
- isolate the BUS itself galvanically both to protect it from tampering and for the correct management of the additional auxiliary power supplies

The articles available in the range are:

art. 03822 basic isolator with the possibility of galvanic isolation of the power supply;

art. 03823 isolator with galvanic isolation of the power supply and regeneration of power supply 13.8V@1A.

#### BUS signal regeneration

The sole regeneration of the BUS signals is obtained using the wiring diagram shown below.

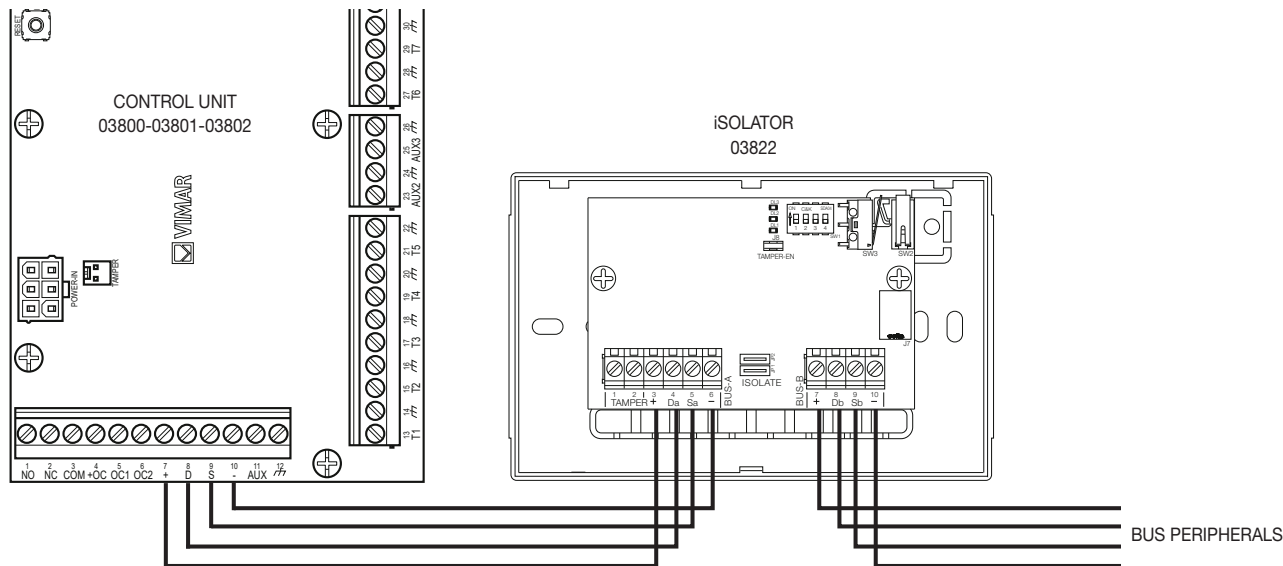

Simply use the isolator art. 03822 with the two connected jumpers (default). In this case, the BUS towards the field peripherals is regenerated and the power supply conductors + and - are the same as the control unit. The BUS signals are on the other hand regenerated, isolated and protected. Install the isolator in an enclosure which is in turn protected.

#### Additional auxiliary power supply unit and regeneration of BUS signals

If you are using an additional auxiliary power supply unit, the wiring diagram is as follows.

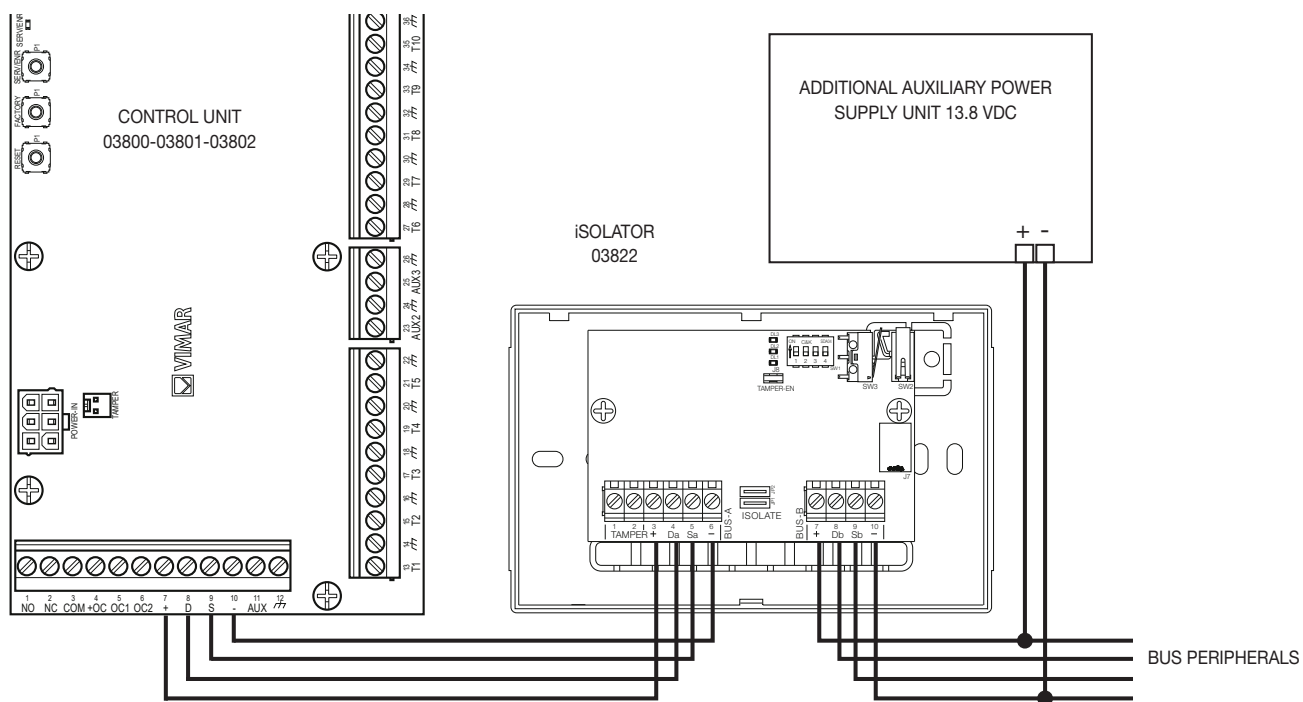

In this case, the isolator art. 03822 is still used but the two jumpers need to be cut. The power supply of the BUS peripherals is galvanically isolated from the control unit and is supplied by the auxiliary power supply unit. The maximum current available depends solely on the characteristics of the auxiliary power supply unit itself.

## Connecting the peripherals to the control unit bus

### Integrated regenerated power supply and regeneration of BUS signals

If the current required to power the BUS peripherals is less than 1A, then isolator art. 03823 can be used as it is equipped with an integrated switching power supply unit capable of supplying 13.8V@1A. The power supply of the BUS peripherals is always galvanically isolated from the control unit. The wiring diagram is as follows.

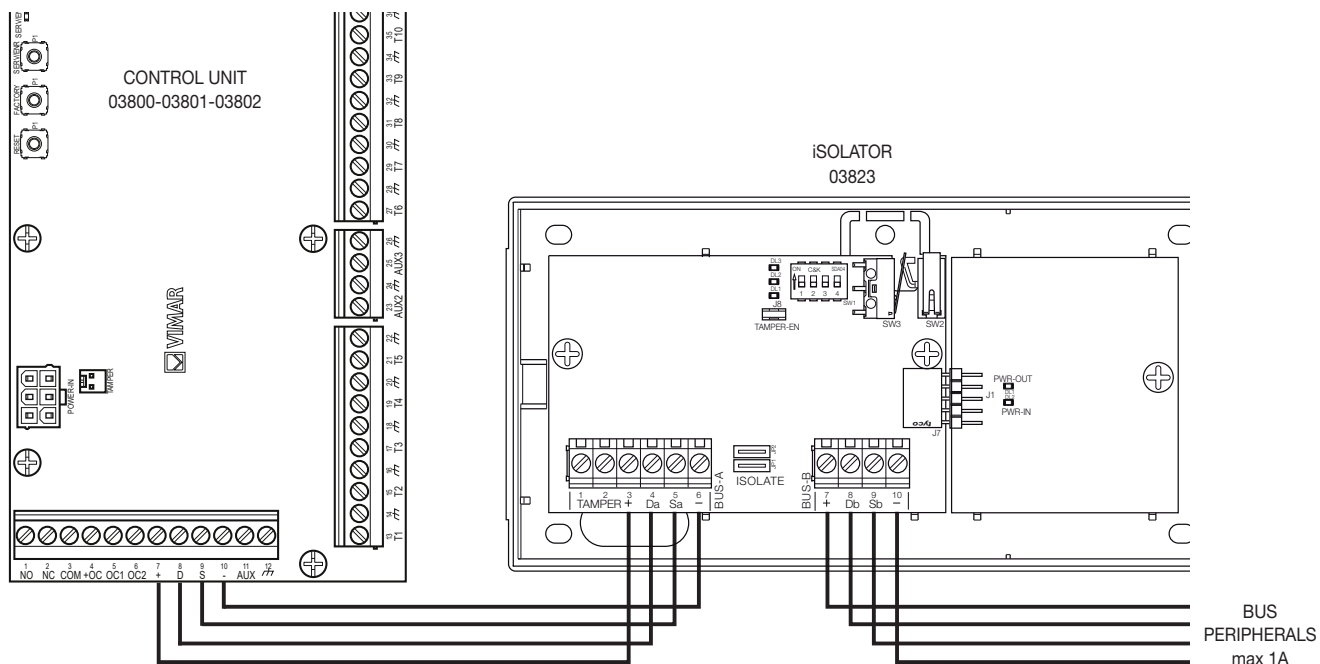

## Connecting alarm sensors and balancing

### 5. Connecting alarm sensors and balancing

Connecting sensors (detectors) and balancing them depends on their type and on the protection degree you wish to achieve. Sensors can be powered:

- by terminals [+AUX/12V] and [-/earth] present on the control unit
- by terminals [+AUX/12V] and [-/earth] present on the expansions, art. 03808 and 03819
- by terminal [+12V] and by terminals [-/mass] present on the keyboards, art. 03818
- by any source of 12V auxiliary power supply provided it has the earth reference (GND) in common with the earth reference of the control unit.

N.B. The terminals constantly provide 12 V but in the By-alarm Plus Manager software, they can be used as programmable outputs; in this case, they must NOT be used to power sensors.

The default resistors used and provided and the related colour bands are:

- 3.3k $\Omega$  1/4 W orange-orange-red gold
- 4.7k $\Omega$  1/4 W yellow-purple-red gold
- 15k $\Omega$  1/4 W brown-green-orange gold

#### CAUTION!

The resistors used must be connected directly to the terminals of the sensors, not to the terminals of the control unit or of the peripherals.

Generally speaking, the level of protection provided by the type of balancing used is shown in the following table

BALANCING	N.O. (norm. open)	N.C. (norm. closed)	Single balancing (one EOL resistor)	Double/triple balancing (two or three EOL resistors)
Level of protection	very low	low	medium	high

#### 5.1 N.C./N.O. balancing

The *Normally open* and *Normally closed* balancing is easy to achieve but are equally unavoidable. No resistors are used for which only two statuses of the terminal which they are connected to can be detected:

- standby
- alarm (violated/activated)

Below is an illustration of the connection structure for the N.C. /N.O. balancing This connection can typically be used for both the terminals of the alarm and sabotage/ tamper signals of the detector.

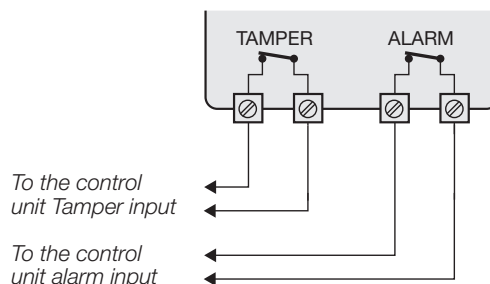

To detect sabotage/tampering, you need to connect the related signal to the terminal configured as MAINTENANCE type GENERAL ZONE

#### 5.2 Single balancing

Single balancing (often indicated as single end-of-line resistor or with single EOL) uses a single resistor for which three statuses of the terminal which it is connected to can be detected:

- standby
- alarm (violated/activated)
- sabotage (via short-circuit)

Below is an illustration of the connection structure for the single balancing.

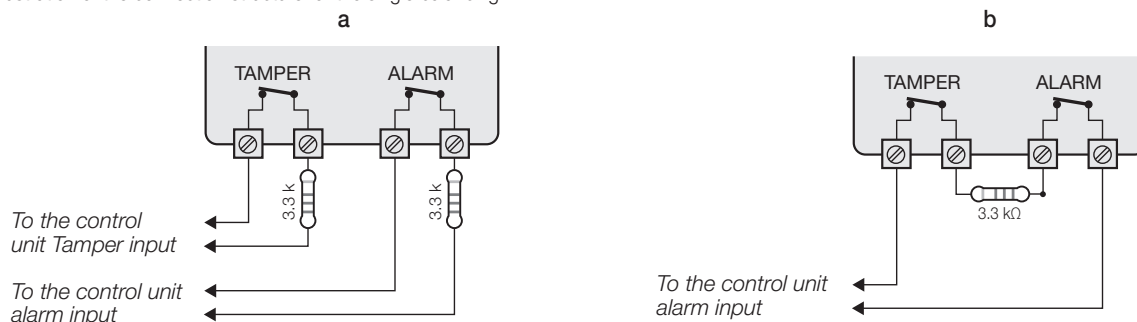

In case a, 2 separate terminals are used for the alarm and tamper signals.

In case b, a single terminal is sufficient for the alarm and tamper signals to be detected correctly.

This connection can typically be used for both the the alarm and sabotage/tamper signals of the detector.

As for the single balancing, for the detection of sabotage/tampering on a dedicated terminal, you need to connect the signal to a 24H input

## Connecting alarm sensors and balancing

### Note

The level of protection of the single balancing is as safe as the double balancing if the sabotage contact of the sensor is connected to a balanced input.

### 5.3 Double balancing

Double *balancing* (often indicated as *double end-of-line resistor* or *double EOL*) uses two resistors, for which four statuses of the terminal which they are connected to can be detected:

- standby
- alarm (violated/activated)
- sabotage (via short-circuit)
- sabotage (via wire cutting/detector opening)

Below is an illustration of the typical connection structure for double balancing.

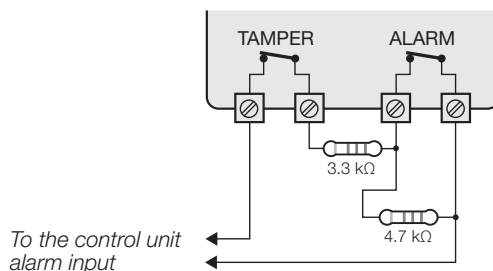

### 5.4 Triple balancing

Triple *balancing* (often indicated as *triple end-of-line resistor* or *triple EOL*) uses three resistors, for which six statuses of the terminal which they are connected to can be detected:

- standby
- alarm (violated/activated)
- anti-masking
- alarm + anti-masking
- sabotage (via short-circuit)
- sabotage (via wire cutting/detector opening)

This balancing is also used to manage two separate detectors on a single terminal; in this case the *anti-masking* signal is replaced by the alarm signal of the second detector.

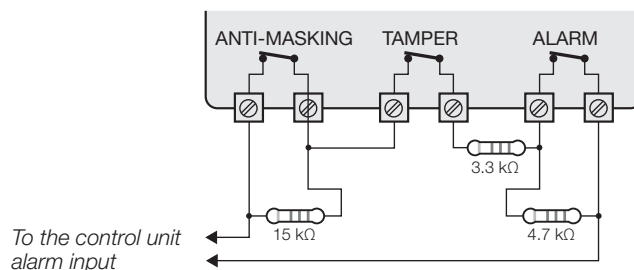

The table below shows the values (expressed in  $\Omega$ ) of the equivalent resistor read at the terminals according to the balancing and signal detected. The table applies to EOL resistors supplied by default, which are 3300 $\Omega$ , 4700 $\Omega$  and 15000 $\Omega$ .

balancing	standby	alarm	tamper (short-circuit)	tamper (cut wires)	anti-masking	Alarm + anti-masking
N.C.	0	> 2200	//	//	//	//
N.O.	> 2200	0	//	//	//	//
Single EOL	3300	> 4700	0	//	//	//
Double EOL	3300	8000	0	> 35000	//	//
Triple EOL	3300	8000	0	> 35000	18300	23000

## Connecting alarm sensors and balancing

### 5.5 Connecting roller shutter/inertia sensors and balancing

In the case of roller shutter or inertia detectors, you can choose between two balancing types:

- normally closed (NC)
- single balancing (similar to NC with EOL resistor).

The table below shows the relationship between the level of protection of roller shutter or inertia sensors with the two envisaged control unit balancing types:

BALANCING Roller shutters/inertia	N.C. (norm. closed)	Single balancing (one EOL resistor)
Level of protection	Very low	high

N.B.

- The roller shutter detection device must generate pulses which last between 500µs and 10 ms.
- If the roller shutter or inertia detection device is connected to a terminal of a radio device, the length of the connection cables must be under 2 m.

#### 5.5.1 Roller shutter/inertia: normally closed (NC)

In this case, the alarm condition is detected solely by counting the pulses detected by the control unit on the terminal.

Using this balancing, no sabotage will ever be detected via cutting of wires or due to short-circuits.

The statuses detected are therefore:

- standby
- alarm

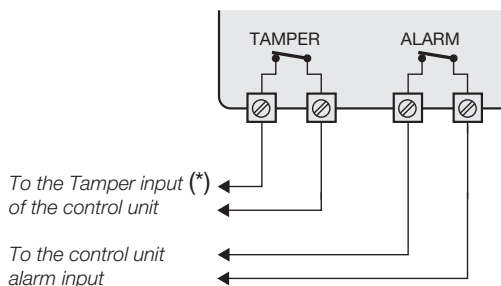

(\*) Generally speaking the roller shutter/inertia detectors do not have a terminal dedicated to sabotage/tampering.

#### 5.5.2 Roller shutter/inertia: single balancing (NC with EOL)

In this case the alarm condition is detected by counting the pulses detected by the control unit on the terminal and the sabotage conditions are detected according to the length of time the terminal remains short-circuited or for cut wires.

The statuses detected are therefore:

- standby
- alarm
- sabotage (cut wires)
- sabotage (short-circuit)

For each of these statuses, the control unit interprets the various values of equivalent resistor on the terminal.

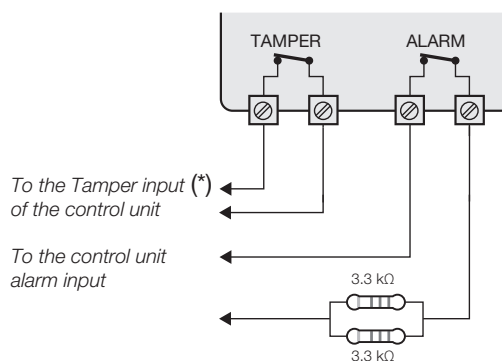

(\*) Generally speaking the roller shutter/inertia detectors do not have a terminal dedicated to sabotage/tampering.

## Connecting sirens

### 6. Connecting sirens

#### 6.1 Connecting an outdoor siren and an indoor siren using a single relay

The relay output of the control unit should be configured by default in other words as ACTIVATION CAUSE (BURGLAR ALARM – BURGLARY/SABOTAGE/SYSTEM SABOTAGE/PANIC – AREA 1).

The outdoor and indoor sirens ring and flash for the duration of the control unit alarm time or until the user performs a “STOP SIRENS” on the keypad.

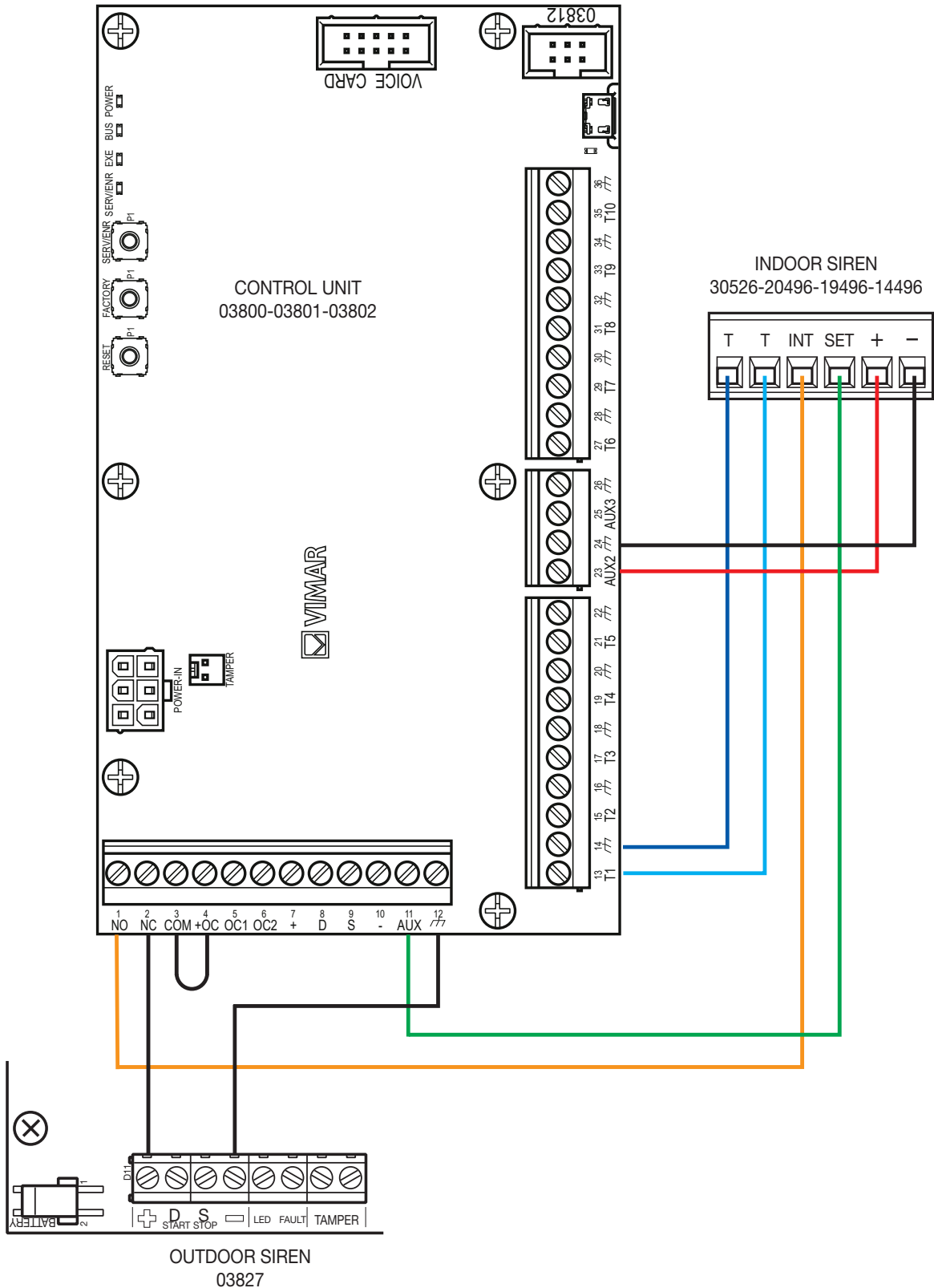

## Connecting sirens

### 6.2 Connecting an outdoor siren and an indoor siren with separate control

The OC1 output of the control unit should be configured as ACTIVATION CAUSE (BURGLAR ALARM – BURGLARY/SABOTAGE/SYSTEM SABOTAGE/PANIC – AREA 1).

The AUX1 output of the control unit should be configured as ACTIVATION CAUSE (BURGLAR ALARM – BURGLARY/SABOTAGE/SYSTEM SABOTAGE/PANIC – AREA 1-DO NOT PARTIALLY ACTIVATE).

The outdoor siren rings and flashes for the duration of the control unit alarm time or until the user performs a “STOP SIRENS” on the keypad.

The indoor siren is only activated if the control unit is TOTALLY ENABLED and it rings and flashes for the duration of the control unit alarm time or until the user performs a “STOP SIRENS” on the keypad.

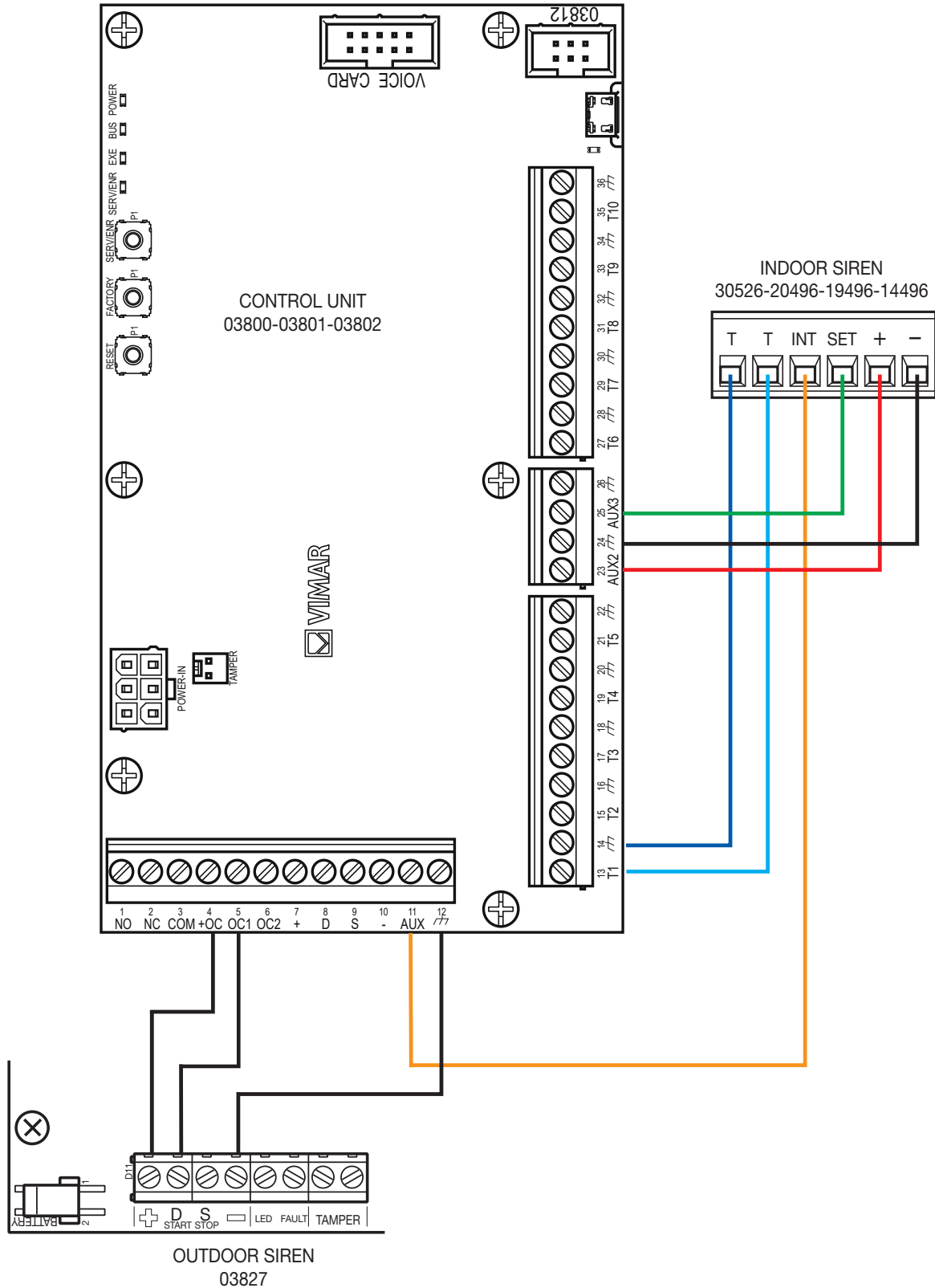



## Connecting sirens

### 6.3 Connecting an outdoor siren using “START” and “STOP” and an indoor siren with separate control

The outdoor siren should be kept at its default configuration.

A terminal of the control unit or of an In/Out expansion or of the keypad should be configured as an OUTPUT and as ACTIVATION CAUSE (BURGLAR ALARM – BURGLARY/SABOTAGE/SYSTEM SABOTAGE/PANIC – AREA 1) and then connected to the D/START terminal of the outdoor siren.

Another terminal of the control unit, or of an In/Out expansion or of the keypad should be configured as an OUTPUT and connected to the stop terminal of the outdoor siren; the latter should be configured as ACTIVATION CAUSE for a control unit event. For example:

- STATUS OF ZONES – ZONE REAL TIME – ZONE xxx : it allows the siren to stop using a push button or a mechanical key (CAUTION: as long as the status of the zones remains active, the siren will NOT perform any visual and sound signalling)
- SIGNALLING – PIN/KEY RECOGNISED: allows the siren to stop following access by a user to the system. In this case, since this is a one-position stable event, an IMPULSE TYPE OF ACTIVATION should be used (CAUTION: for the duration of the pulse at the output, the siren does NOT perform any visual and sound signalling; this pulse must last longer than the control unit alarm time to ensure the siren is fully silenced).

The AUX1 output of the control unit should be configured as ACTIVATION CAUSE (BURGLAR ALARM – BURGLARY/SABOTAGE/SYSTEM SABOTAGE/PANIC – AREA 1- DO NOT PARTIALLY ACTIVATE).

The outdoor siren rings and flashes for the duration of the control unit alarm time or until the user performs a “STOP SIRENS” on the keypad or using the event configured to pilot the stop terminal.

The indoor siren is only activated if the control unit is TOTALLY ENABLED and it rings and flashes for the duration of the control unit alarm time or until the user performs a “STOP SIRENS” on the keypad.

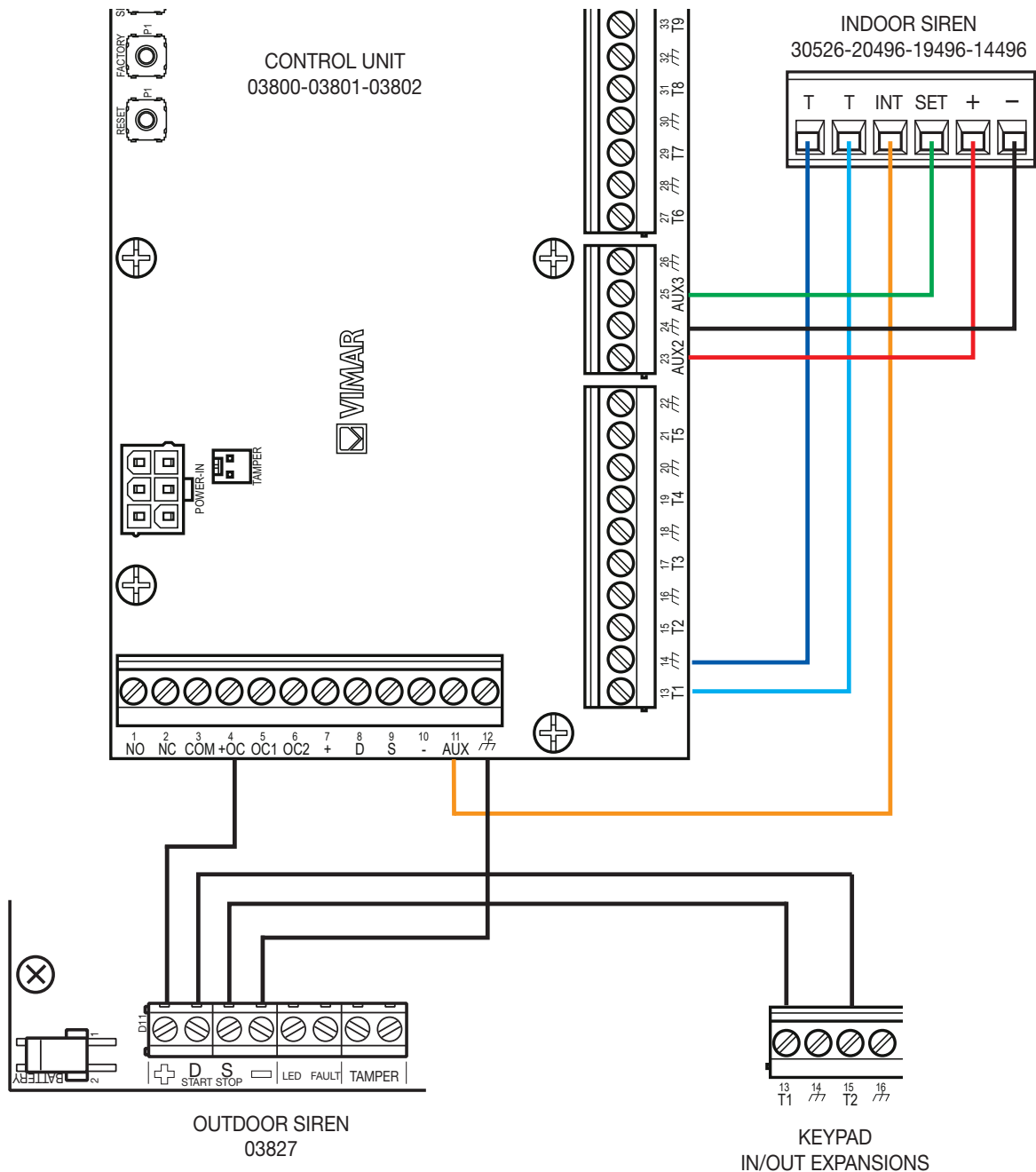

## Connecting sirens

### Characteristics of the START and STOP terminals

The START and STOP terminals operate in a static manner, in other words, depending on their on/off status, they determine the behaviour of the siren.

In practice, the operation of the siren is **NOT determined by pulses on START and STOP**.

Keep in mind that the on/off status of the START and STOP terminals is aligned with the configuration assigned to the "START Input" and "STOP Input" parameters.

The following table and graph illustrate the behaviour of the siren according to the status of the START and STOP terminals.

START	STOP	SIREN STATUS
on	off	ON
on	on	OFF
off	on	OFF
off	off	OFF

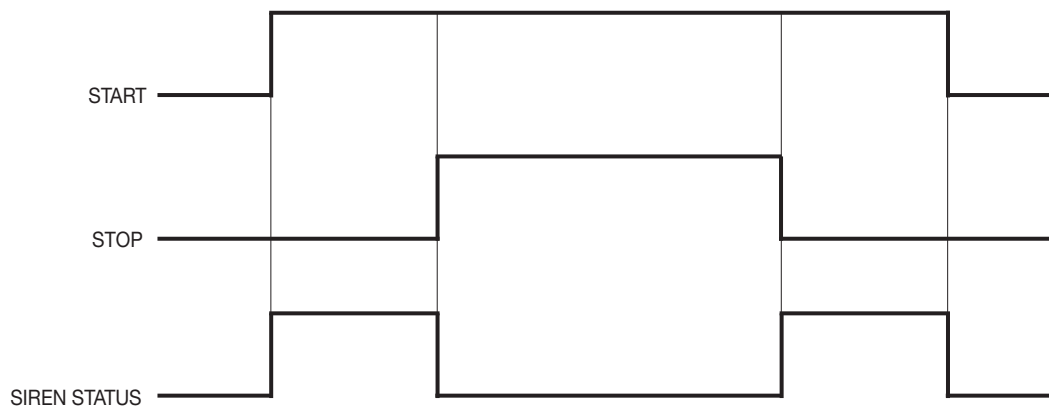

## Connecting sirens

### 6.4 Outdoor siren LED control

The outdoor siren should be kept at its default configuration.

A terminal of the control unit, or of an In/Out expansion or of the keypad should be configured as an OUTPUT and connected to the LED terminal of the outdoor siren; the latter should be configured as ACTIVATION CAUSE for a control unit event for which you wish to trigger the signalling on the LED of the outdoor siren.

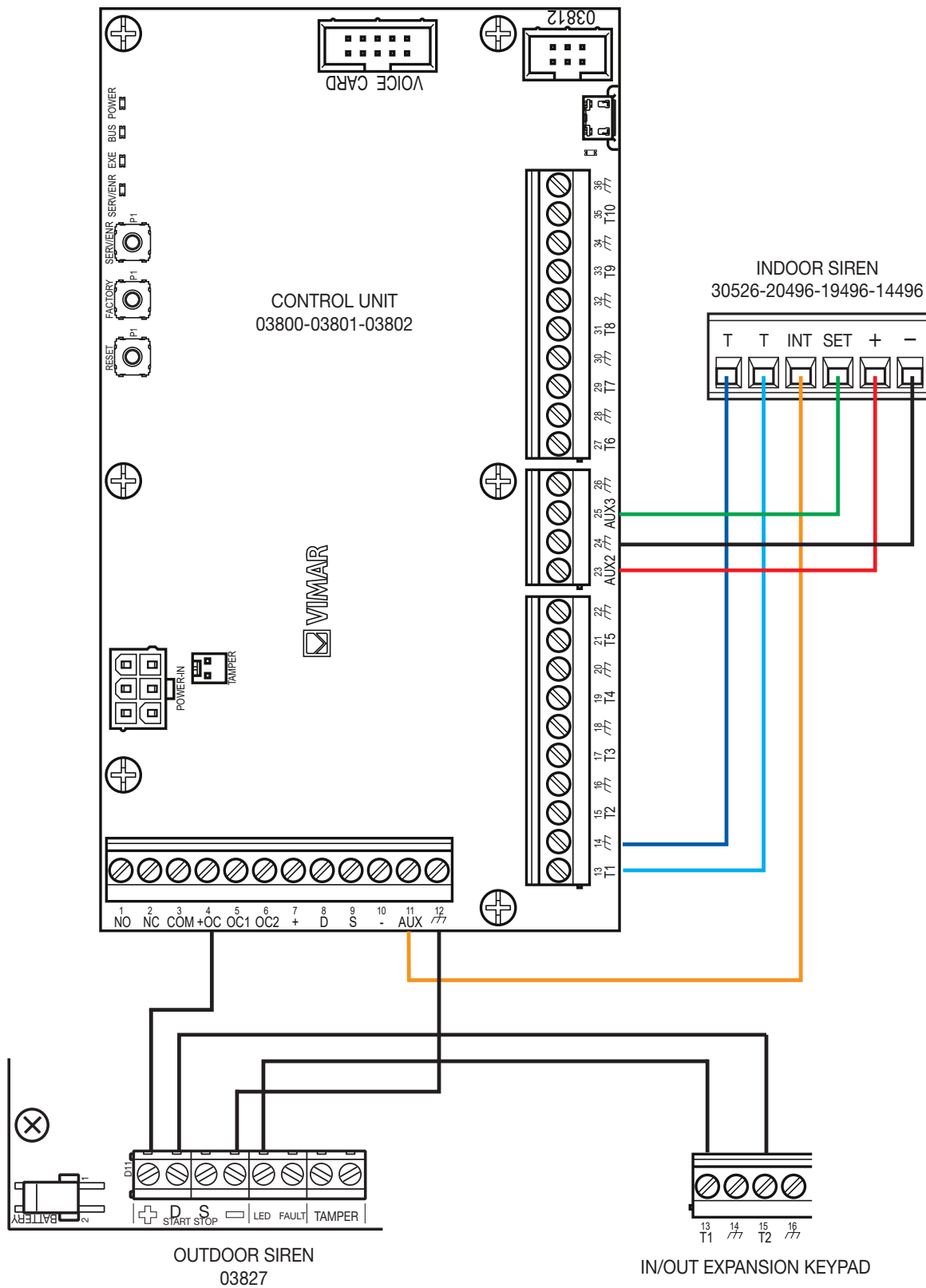

## Connecting outputs

### 7. Connecting outputs

#### 7.1 Auxiliary power supply terminals

The +OC terminal is an auxiliary 13.8 V power supply terminal with a maximum current of 350 mA.

#### 7.2 Programmable, supervised auxiliary power supply terminals

The AUX1, AUX2 and AUX3 terminals are programmable, supervised 13.8 V auxiliary power supply terminals with a maximum current of 1.5 A. They are protected against voltage and current surges and short circuits.

They can be referenced by control unit events.

#### 7.3 Connecting open collector outputs

OC1 and OC2 are open collector outputs designed to pilot maximum currents of 500 mA;

All the Tx terminals for configuration as outputs are open collector designed to pilot up to 250 mA.

The figure below illustrates a typical connection example for the activation of a load upon the earthing closing of a normally open (NO) output.

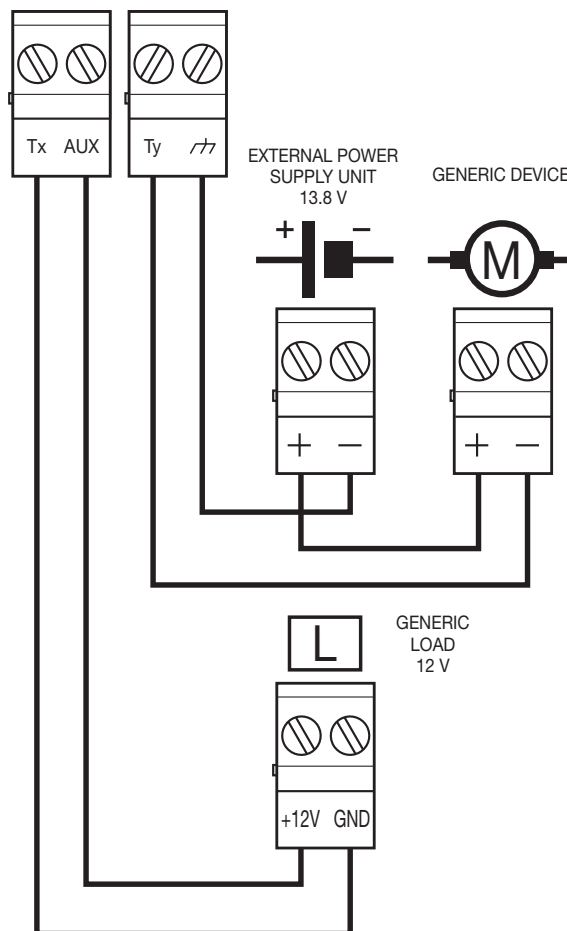

For the connection of the outputs to terminals T1 and T2 of the radio magnetic contact art. 03833 please refer to the related instruction sheet.

## Notifications

### 8. Notifications

The following tables contain system notifications in relation to the grades required by standard EN 50131-1.

Notification Device	A	B	C	D	E	F	Grade
Acoustic WD with remote power supply	2	-	-	-	-	-	2
Self-powered acoustic WD	-	1	-	-	1	-	2
ATS	SP2	SP2	DP1	SP2	-	DP2	2

Key:

SP2: GSM communicators art. 03810 and 03820 which use the voice protocol (signalling time 25 h)

SP3/6: GSM/GPRS/UMTS/HSPA/LTE communicators art. 03810 and 03820 which use SIA IP (signalling time 30 min or 20 s)

SP2/3: Burglar alarm system gateway art. 03812 which uses the Vimar Cloud (signalling time 25 h or 30 min)

DP1/2: GSM communicators art. 03810-03820 and Burglar alarm system gateway art 03812 which use the voice protocol (signalling time 25 h or 30 min)

Notification Device	A	B	C	D	E	Grade
Acoustic WD with remote power supply	2	-	-	-	-	3
Self-powered acoustic WD	-	1	-	-	-	3
ATS	SP3	SP3	DP2	SP4	-	3

Key:

SP3/6: GSM/GPRS/UMTS/HSPA/LTE communicators art. 03810 and 03820 which use SIA IP (signalling time 30 min or 20 s)

SP3: Burglar alarm system gateway art. 03812 which uses the Vimar Cloud (signalling time 25 h or 30 min)

DP2: GSM communicators art. 03810-03820 and Burglar alarm system gateway art 03812 which use the voice protocol (signalling time 25 h or 30 min)

SP4: Burglar alarm system gateway art. 03812 which uses the Vimar Cloud (signalling time 3 min)

## Routing peripherals - First power-up - Integration with the By-me Plus home automation system

### 9. Routing peripherals

All the peripherals connected to the BUS must have unequivocal logic addresses to be correctly identified by the control unit. Different types of peripherals can have the same address (for instance address 3 for a keypad and for an expansion), whereas two peripherals of the same type must under no circumstances have the same address.

Each peripheral has an unequivocal Qr-code . The QR-code is shown in both graphic and clear form. It is an alphanumeric text comprising 14 characters. It contains information required for the operation of the peripherals in the system and it determines their safety.

For example:

2C412345678032 

The first 3 characters 2C4 identify the product (in this case keypad art. 03818), the other digits determine its unequivocal nature.

**It is not possible to replace a peripheral with another simply by installing it with the same logic address; you always need the QR-code + logic address pair to be approved in the control unit.**

The control unit can only be connected with a single GSM/LTE communicator, so no procedure for assigning the address is envisaged.

### 10. First power-up

Upon first power-up of the control unit, all the parameters are initialised at the default values (factory settings).

To perform the first power-up of the system correctly, we recommend you follow the procedure set out below.

#### CAUTION!

**During wiring, never power the control unit and peripherals, using neither the mains voltage (230V~) nor the buffer battery.**

- 1) Install the control unit in the dedicated enclosure (art. 03814, 03815, 03816).
- 2) Wire all the peripherals on the BUS
- 3) Connect the BUS cables to the control unit
- 4) Balance and connect the sensors
- 5) Connect the sensors to the terminals
- 6) Connect the outputs to the control unit and to the peripheral terminals
- 7) Where available, connect the voice card art. 03813 to the dedicated connector
- 8) Connect the primary power supply (230V~)
- 9) Connect the buffer battery and the temperature probe
- 10) Perform the routing and system configuration using one of the procedures described in chap. 2.

### 11. Integration with the By-me Plus home automation system

For full details on the integration of the By-alarm Plus system with the By-me Plus home automation system, in other words on how to make gateway 03812 interact with gateway 01410-01411, please see the chapter entitled "By-alarm Plus burglar alarm system gateway art. 03812" in the VIEW IoT Smart System platform manual.

#### 11.1 How to set up remote access using the View Pro App.

Using the keypad and assigning the authorisations for remote access, the user should allow the installer to access the system:

Enter the PIN on the keypad → press the button  → select INSTALLER → AUTHORISATIONS: Remote SW access set to ON.

Then consult para. "Integration of By-alarm and video door entry devices with By-me Plus applications" in the By-me Plus system manual.

**Important:** When you connect gateway 03812 to the control unit, the latter registers its presence and adapts the procedures to include the gateway into its operation.

If the gateway is subsequently removed, the control unit does not reset normal operation without the gateway; this mode is used by certain installers who for the sake of convenience configure the system with gateway 03812 and then remove it to leave the customer with the stand-alone solution of the system.

In the event that gateway 03812 is removed from the system with the control unit already configured, after 60 s, the control unit will display the fault message "Gateway disappeared" on the keypad; in the presence of this message, select the following in the keypad installer menu:

"System reset" → "Delete disappeared gateway" and press 

gateway 03812 will be removed from the control unit configuration. The fault will nevertheless remain in the memory so simply delete it to remove all traces of the gateway you just removed.

#### NOTES:

- The events log will keep a trace of the disappearance and reset caused by the deletion operation performed by the installer.
- In the event of temporary communication problems between the control unit and gateway 03812 or if the "disappeared" gateway is disconnected and reconnected to the control unit after more than 60 s, the "Gateway disappeared" signalling will be displayed as fault memory. If this is the case, the "Delete disappeared gateway" sub-menu will not be available in the installer menu on the keypad.

## Integration with the By-me Plus home automation system

---

### 11.2 Accessing the keypad as an Installer user

Press and hold down button  at length then enter the Installer PIN (the default value is "9999").

The list of available menus is displayed:

- "Logout": allows you to quit the installation session and go back to the main page
- "Under maintenance": allows you to activate system maintenance (ON) or deactivate it (OFF)
- "Diagnostics": runs diagnostics on
  - "Control unit data": displays the S/N, size, FW and HW versions and battery level.
  - "Wired Peripherals": displays, divided by category, information about the S/N, FW and HW versions, operating status of each device in the system.
  - "Radio devices": displays, divided by category, information about the S/N, FW and HW versions, operating status, battery level of each radio device in the system.
  - "Zones": displays the description and allows you to exclude or inhibit the zone.
  - "Walk test": activates the function to check the sensor detection is working properly.
  - "Radio system": activates radio carrier attenuation.
- "Programming": allows you to enrol the transponder keys
- "System reset": allows you to delete the faults memory, alarms memory, notifications, silencing of sirens and restore the control unit to its factory settings
- "Events Log": allows you to display the events stored; you can filter which ones to display (ALL, ALARMS, FAULTS, ACTIVITIES)
- "PIN Code": allows you to request a new PIN
- "Authorisations": allows you to display the authorisations for Installer and User.

## Faults viewable on the keypad

### 12. Faults viewable on the keypad

FAULT on keypad	SUB-FAULT on keypad	ADDITIONAL DESCRIPTION on keypad	FAULT DESCRIPTION	SUB-FAULT DESCRIPTION
No primary power supply	-	-	Control unit AC mains power supply interruption	-
Problem with power supply unit	Overload	-	Control unit power supply unit fault	Maximum current exceeded
	Over-temperature	-		Over-temperature
	No Earth	-		Problem with earth cable
	No communication	-		Problem communicating with the control unit
Control unit battery low	-	-	Control unit battery level low	-
Problem with battery pack	Inefficiency	-	Control unit battery fault	Battery inefficient, needs replacing
	Short-circuit	-		Short-circuited battery
	Disconnected	-		Battery disconnected
Problem with the Bus	Voltage surge	-	Fault on peripheral BUS	Bus power supply DC voltage high
	Low voltage	-		Bus power supply DC voltage low
	Short-circuit	-		Bus power supply short-circuited
	Overload	-		Maximum bus power supply current exceeded
Problem with peripheral DC	Disconnected	<i>Name of the device</i>	Radio repeater device power supply fault	No DC power supply
Problem with peripheral battery	Disconnected	<i>Name of the device</i>	Radio device or GSM/LTE communicator battery fault	Battery disconnected
Touch screen anomaly	Touch screen disconnected	-	Touch screens configured but not connected to the system	-
	Alarm not notified	-	Alarm not notified on the Touch screens because they are not connected	-
Peripheral disappeared	-	<i>Name of the device</i>	Device on bus or radio disappeared	-
Peripheral battery low	-	<i>Name of the device</i>	Radio device or GSM/LTE communicator battery low	-
Malfunctioning outputs	-	<i>Name of output</i>	Output fault	-
Problem with AUX 1	Voltage surge	-	AUX 1 terminal fault	High DC voltage
	Low voltage	-		Low DC voltage
	Short-circuit	-		Short-circuited towards earth
	Overload	-		Maximum current exceeded
Problem with AUX 2	Voltage surge	-	AUX 2 terminal fault	High DC voltage
	Low voltage	-		Low DC voltage
	Short-circuit	-		Short-circuited towards earth
	Overload	-		Maximum current exceeded
Problem with AUX 3	Voltage surge	-	AUX 3 terminal fault	High DC voltage
	Low voltage	-		Low DC voltage
	Short-circuit	-		Short-circuited towards earth
	Overload	-		Maximum current exceeded



**Faults viewable on the keypad**

FAULT on keypad	SUB-FAULT on keypad	ADDITIONAL DESCRIPTION on keypad	FAULT DESCRIPTION	SUB-FAULT DESCRIPTION
Date and time lost	-	-	Date and time at factory settings	-
Radio channel black-out	1	-	Disturbance or jamming attempt on one of the via-radio channels	Channel 1 blacked out
	2	-		Channel 2 blacked out
	3	-		Channel 3 blacked out
	4	-		Channel 4 blacked out
Problem with mobile data link	-	-	GSM/LTE communicator not connected to data network (no operator data network or incorrect APN configured)	-
Problem with mobile voice link	-	-	GSM/LTE communicator not registered on the operator network or problem with the SIM	-
Gateway disappeared	-	-	Problem communicating with gateway 03812 or gateway disconnected	-
Problem with peripheral link	No communication	Name of the device	Device communication problem towards the panel or towards other peripheral devices	The transceiver has not received data from any radio device for at least 20 minutes

**13. Troubleshooting**

Connection via USB cable not working - User not recognised	<p>Make sure the Installer PIN entered is correct (9999 by default).</p> <p>Disconnect the connector and check the list of COM ports available. After re-connecting the USB connector a new COM port is displayed; select it and perform the connection check.</p> <p>if the problem persists, reset the control unit (see the instruction sheet for the control unit 03800-03801-03802).</p>
Connection via LAN not working - User not recognised	<p>Make sure you created the system using the View Pro App and that the By-alarm Plus gateway 03812 has been associated with the system.</p> <p>Make sure you have entered the IP address and the port provided by the View Pro App.</p> <p>Make sure the connection with the gateway 03812 has been made using the appropriate Ethernet cable.</p> <p>Make sure the Installer PIN entered is correct (9999 by default).</p> <p>if the problem persists, reset the control unit (see the instruction sheet for the control unit 03800-03801-03802).</p>
The View App does not work after adding gateway 03812	Make sure you have "delivered" the system using the View Pro App.
The keypad displays the "GSM Fault" message	The system generates this message when module 03810 or 03820 cannot find an operator or when the SIM hasn't been inserted.
"PIN revealed" alarm reset	<ol style="list-style-type: none"> <li>1. Enter the Installer PIN in the keyboard and press key  (or from any menu press the back key for around 2 s); select the INFO key.</li> <li>2. The "PIN code revealed" warning can be found in the "YELLOW" menu (with an indication of the user whose PIN has been revealed); scroll through the items, select the "PIN code revealed" warning and press OK</li> <li>3. The screen indicating "PIN code revealed - Reset" appears; wait for a few seconds and the warning will be deleted</li> </ol>





By-alarm Plus 04 2407