

Terminal for communications and displaying calls formed by display module and voice unit module, power supply 24 V d.c. SELV, complete with double base for semi-recessed installation on light walls, on boxes with 60 mm distance between centres or on 3-gang boxes.

The device, installed inside the single room, is composed of the display module and the voice unit module. The display module enables sending and managing calls made by patients and/or by medical and paramedical personnel and displaying the data relating to the calls (room number, bed number, call level, events memory, etc.).

The device, after a simple configuration, can be used without distinction as a room module or for control; it is equipped with 4 front buttons for assistance and emergency calls, presence and scrolling events list.

The device, after a simple configuration, can be used either as a room module or as a supervisor module; it features 4 front buttons for assistance and emergency calls, presence, events list scrolling and 5 configurable inputs. The display module moreover enables connecting the landing light 02084 to signal nurse present, bathroom call and room call. On stand-by (that is to say when no operations are carried out on the device), the display shows the current time if the system contains a PC.

The voice unit module enables hands-free communication between patient and nurse and between nurses; via the voice unit module it is moreover possible to make room, ward and general announcements and broadcast a music channel with the possibility of adjusting the listening volume. The device is equipped with 4 front buttons to activate voice communication, switch on and off and adjust the volume (decrease and increase) of the music channel.

The antibacterial treatment ensures full hygiene thanks to the action of the silver ions (AG+), which prevent the formation and spread of germs, bacteria, viruses and fungi. To maintain the hygiene and effectiveness of its antibacterial action, clean the product regularly.

CHARACTERISTICS.

- Supply voltage: 24 V d.c. SELV ±20%.
- Absorption: 70 mA.
- Lamp output absorption: 250 mA max.
- LED output absorption: 250 mA max.
- Tail call lead absorption: 3 x 30 mA (30 mA each).
- Speaker output power: 0.15 W/16 Ω.
- Speakers: 2 x 8 Ω -250 mW in series.
- Operating temperature: +5 °C - +40 °C (indoor).

FRONT VIEW.

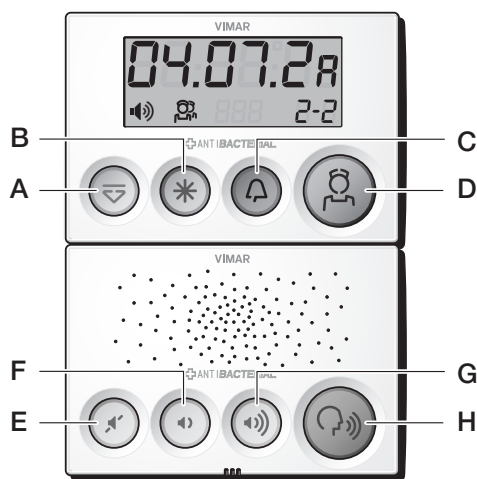

- **Push-button A:** Scrolling through events list (in the configuration phase: confirms operation).
- **Button B:** Emergency call
- **Button C:** Normal or assistance call (in the configuration phase: increase/decrease, yes/no).
- **Push-button D:** Nurse present (in the configuration phase: increase/decrease, yes/no).
- **Button E:** Switching music channel on/off and controlling voice direction (press to speak).
- **Button F:** Decrease volume (only music channel).
- **Button G:** Increase volume (only music channel).
- **Button H:** Voice communication.

DISPLAY.

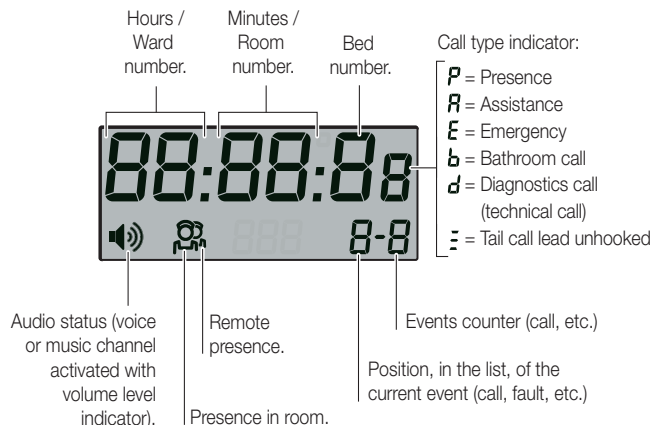

MAIN SCREENS

- 11:23** Rest
Display of time supplied by central unit (provided by the PC indicates that on-line mode or display of corridor).
- 11:23** Presence on or supervisor display (the time is given by the PC that indicates on-line mode or corridor display)
- 05.04** Normal call from same room:
• Ward 5 • Room 4
- 05.04.2E** Emergency call from same room:
• Ward 5 • Room 4 • Bed 2
- 05.04.2E** Remote emergency call:
• Ward 5 • Room 4 • Bed 2
Position 2 in a list of five events.
- 05.04. P** Remote presence display.
Position 1 in a list of four events.
- 23:11** Voice channel or music channel on with intermediate volume (at 23:11 hours).
- 05** Rest (in the absence of PC).
- 05** Presence inserted or control display (in the absence of PC).

CONNECTIONS.

POWER SUPPLY.

+ OUT (24 V d.c. SELV): connection for common power supply elements of bedroom/bathroom call units (14501.AB, 14503.AB), bathroom reset (14504.AB) and outdoor lamp (02084)

- : negative connection for passive unit when required.

BUS.

+, - : Power supply 24 V d.c. SELV.

D1, D2 : Data connection.

F1, F2 : Voice connection.

M1, M2 : Music speaker connection.

Local BUS voice unit connection (voice unit module).

JP1: terminals for connection to display module 02081.AB.

INPUTS/OUTPUTS.

- BUZ** : external buzzer piloting
- G** : outdoor lamp (nurse presence)
- W** : outdoor lamp (bed call)
- R** : outdoor lamp (room/bed call)
- G2** : outdoor lamp (emergency/diagnostics call)
- BED3L** : bed 3 reassurance LED
- BED3C** : bed 3 call (art. 14501.AB or 14342.AB or 14505.AB)
- BED2L** : bed 2 reassurance LED
- BED2C** : bed 2 call (art. 14501.AB or 14342.AB or 14505.AB)
- BED1L** : bed 1 reassurance LED
- BED1C** : bed 1 call (art. 14501.AB or 14342.AB or 14505.AB)
- WCCL** : bathroom reassurance LED
- WCC** : bathroom call (art. 14503.AB)
- WCRL** : bathroom reassurance LED
- WCR** : bathroom reset (art. 14504.AB)

Note: The communication terminal, via the inputs BED3C, BED2C, BED1C, WCC and WCR and by suitably configuring the management software, can be used in the following configurations:

- Traditional room**
- 3 bed calls, 1 bathroom call and 1 bathroom reset;
 - 2 bed calls, 2 diagnostics calls and 1 bathroom reset;
 - 2 bed calls, 2 diagnostics calls and 1 bathroom call;
 - 4 bed calls and 1 bathroom call;
 - 5 bed calls.

- Corridor bathroom**
- 4 cabins and one bathroom reset;
 - 5 cabins.

The unshielded Cat 3 telephone cable can be used for connecting the buttons and lights.

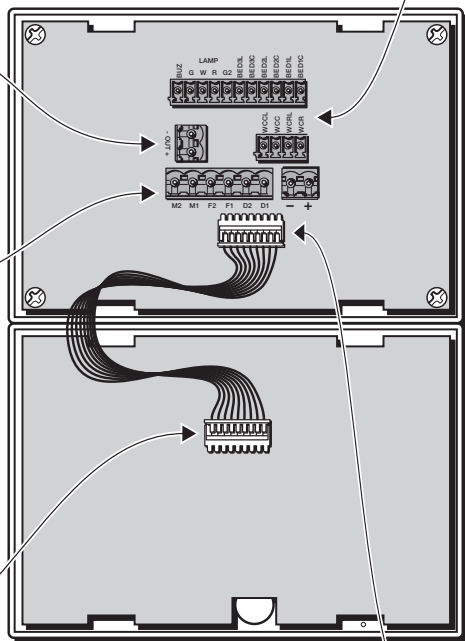

Local BUS voice unit connection (display module).

JP2: terminals for connection to voice unit module 02082.AB.

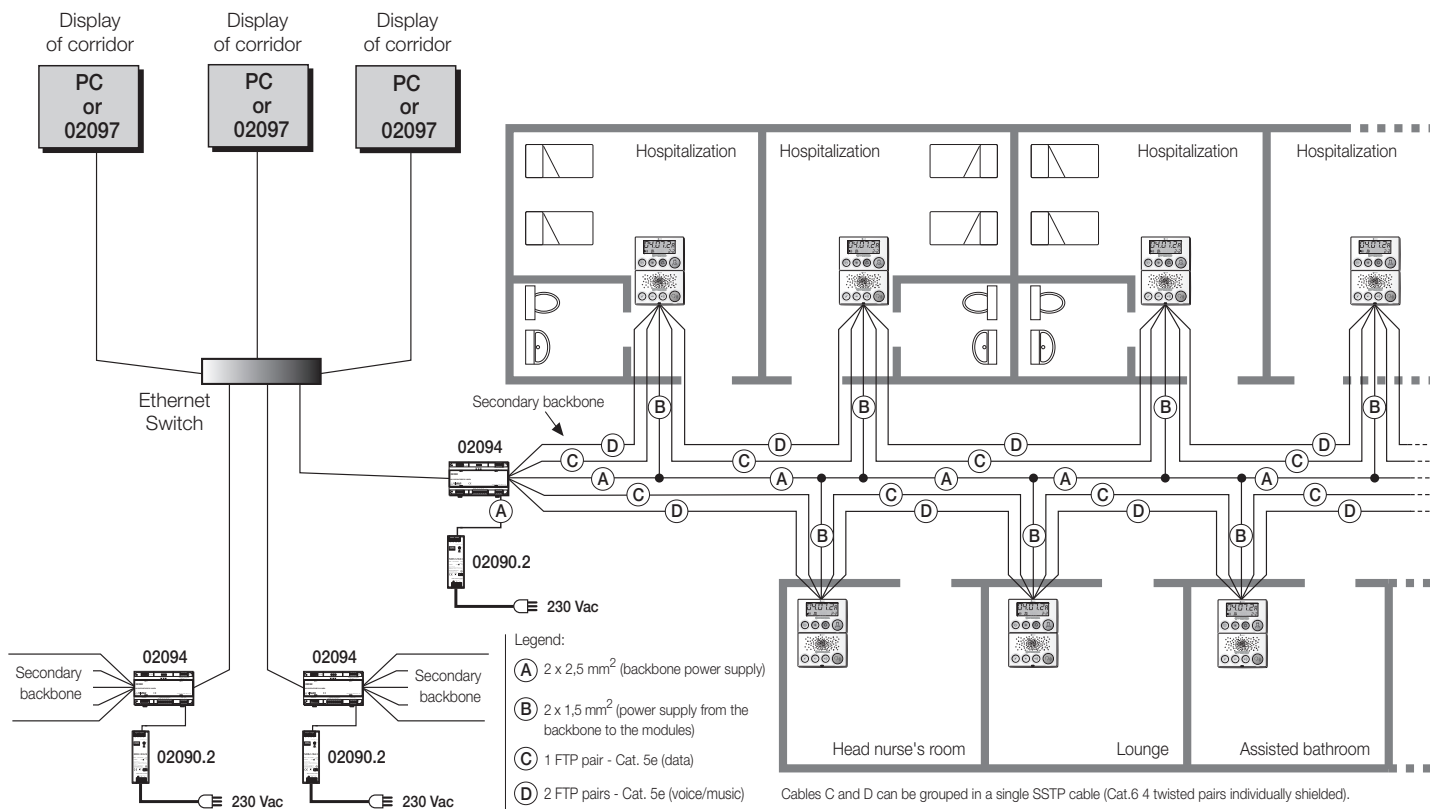

INSTALLATION ON LIGHT WALLS

INSTALLATION ON ROUND FLUSH-MOUNTING BOXES
WITH FIXING CENTRE DISTANCE 60 mm.

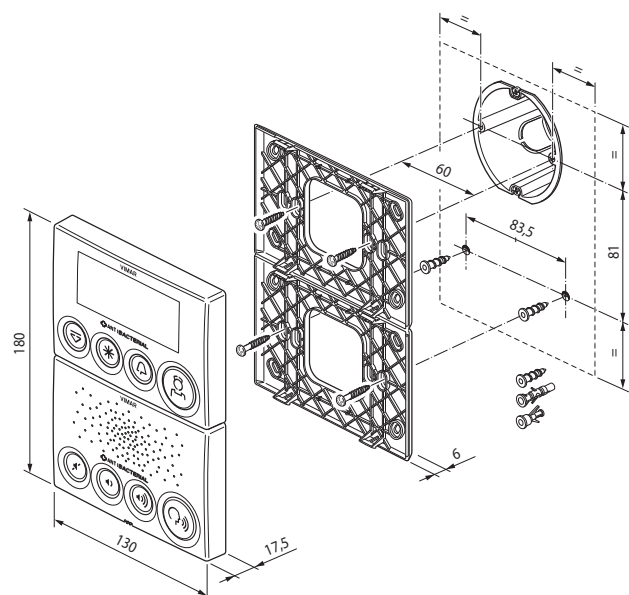

INSTALLATION ON 3-MODULE FLUSH-MOUNTING BOXES.

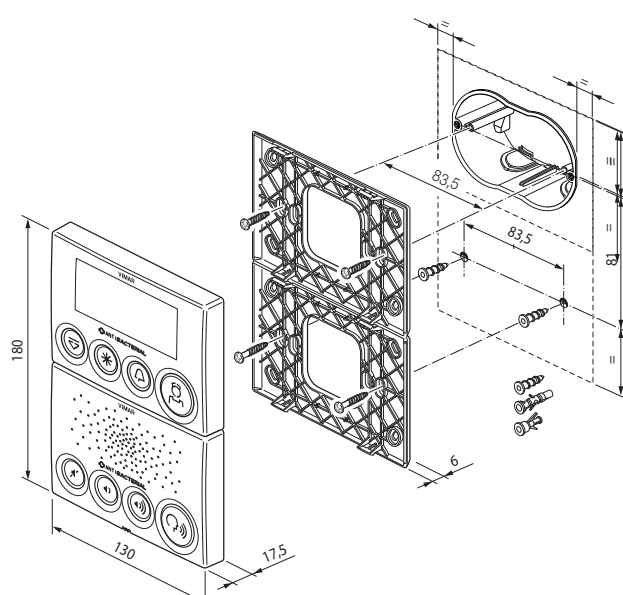

INSTALLATION ON BRICK WALLS

INSTALLATION ON 3-MODULE RECTANGULAR FLUSH-MOUNTING BOX.

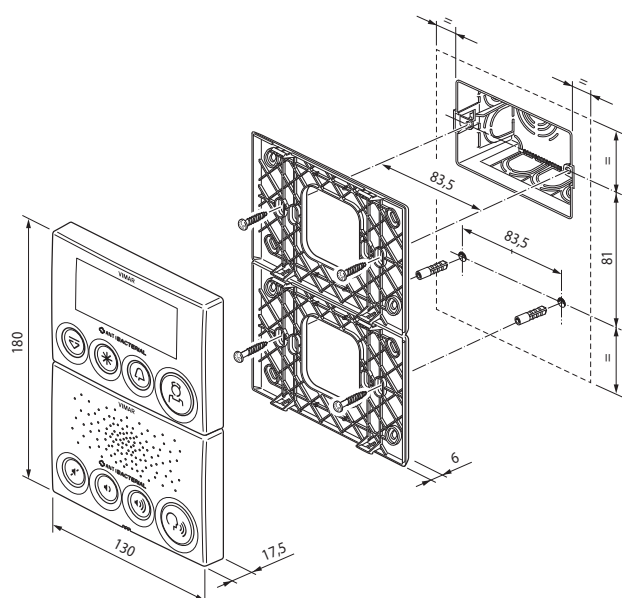

INSTALLATION ON ROUND FLUSH-MOUNTING BOX
AND BASE FIXING WITH PLUGS AT TOPS.

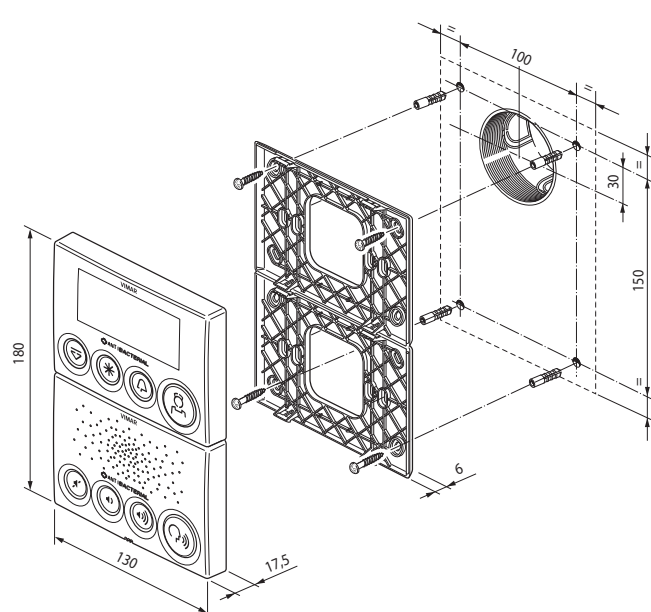

1 - MODULE ASSEMBLY

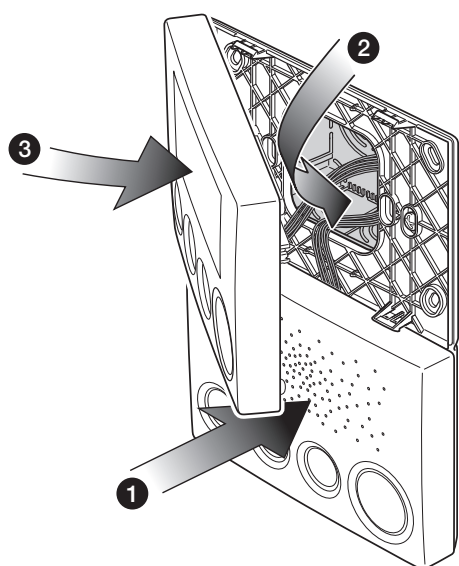

1. Connect the voice unit module.
2. Arrange the connection cables inside the box.
3. Connect the display module.

3 - UNHOOKING THE DISPLAY MODULE

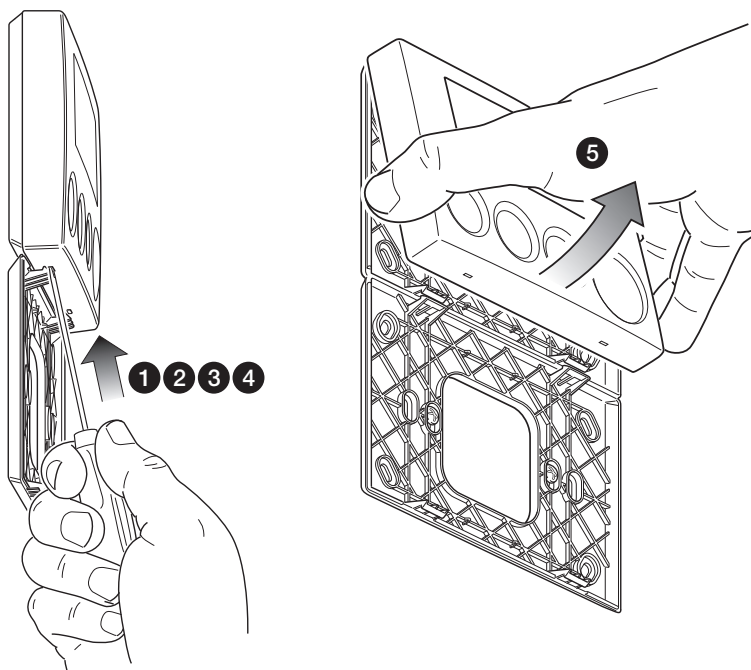

- 1, 2, 3, 4. Carry out the same operations illustrated for unhooking the voice unit module.

5. Extract the display module.

2 - UNHOOKING THE VOICE UNIT MODULE

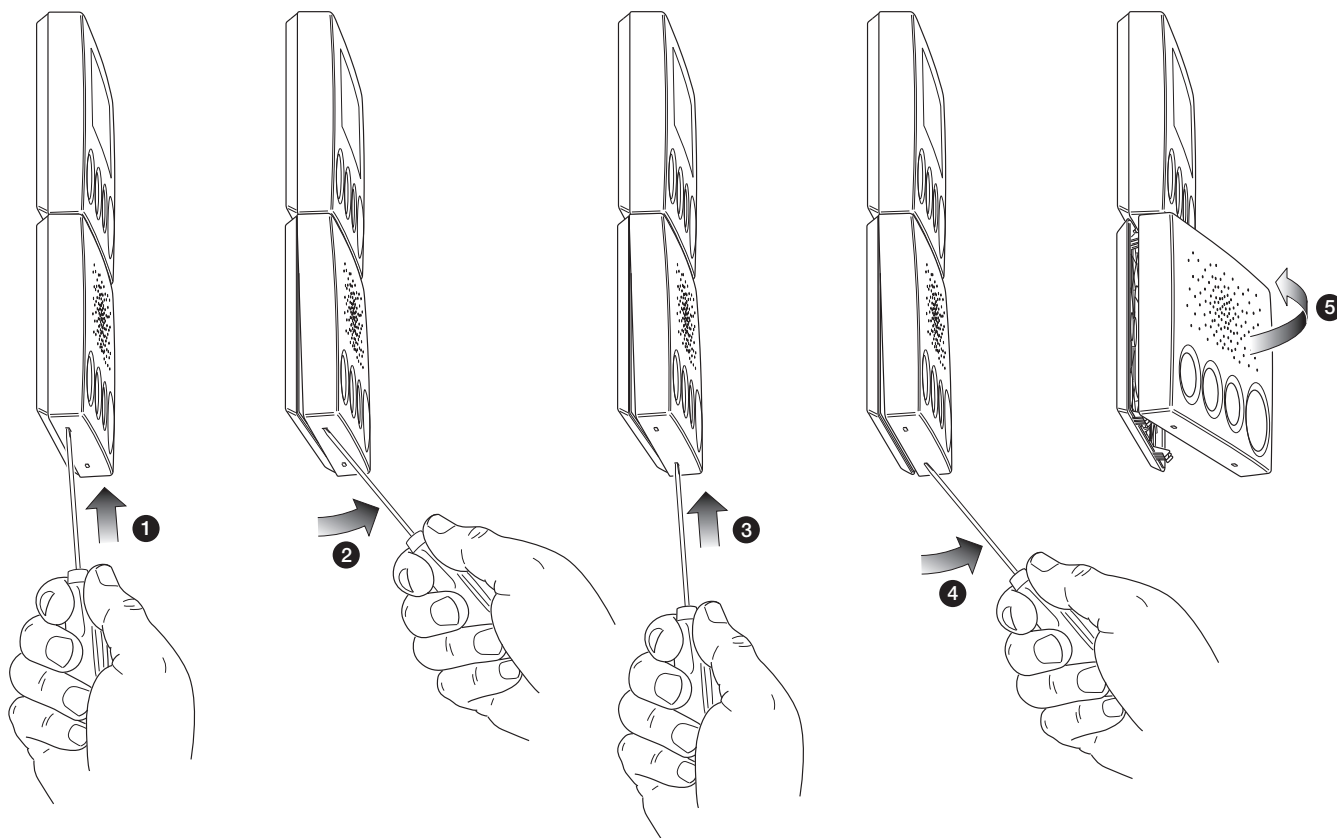

1. Insert and gently push a small Phillips screwdriver into the hole.

2. Press lightly to unhook one side of the module.

3. Insert and gently push the screwdriver into the second hole.

4. Press lightly to unhook the other side of the module.

5. Extract the module.

OPERATION.

The display module is used to perform the following functions:

Call.

The call can be made:

- by pressing the red button (A) (C) for a room call;
- using the button or the tail call lead installed in the bed unit (accidentally unhooking the tail call lead produces a call);
- with a ceiling pull;
- generated by a change in status of a diagnostics input (for example from electro-medical equipment that detects a fault or a serious condition of the patient).

Presence indicator.

Personnel entering the room after a call or for a simple check, signal their presence by pressing the green button (D) on the display module or the reset button 14504.AB. All the rooms equipped with a display module that have the presence indicator on will receive calls from the other rooms in the ward and the personnel will be able to perform the required assistance promptly.

Answering calls.

Whenever a call comes from rooms in the ward the personnel enter the room and signal their presence by pressing the green button (D).

IMPORTANT:

Calls in on-line mode can be made in four different types of level according to the critical level of the situation:

- **Normal:** in conditions of rest press the red call button (A) (C) or 14501.AB or the call lead connected to 14342.AB or 14503.AB (bathroom call).
- **Assistance:** with personnel present in the room (arriving after a Normal call and that press the green presence indicator button (D) the red button (A) (C) or 14501.AB or the call lead connected to 14342.AB or bathroom call 14503.AB is pressed.
- **Emergency:** with personnel present in the room (therefore after pressing the button (D) the dark blue button (B) is pressed and it is kept pressed for approximately 3 s; this type of call is made in situations of extreme seriousness that require immediate medical assistance.

An emergency call can also be generated in the following ways:

- Button 14501.AB (3 sec) with presence previously inserted (button (D));
- Tail call lead button call lead connected to 14342.AB (3 sec) with presence previously inserted (button (D));
- Ceiling pull; 14503.AB (3 sec) with presence previously inserted button 14504.AB.

The LEDs of the buttons that generate the emergency call flash.

- **Diagnostics:** if a diagnostic input changes state, the system produces a technical alarm (anomaly or critical situation of a patient). The different call levels and the Diagnostics function are available both on-line and in VDE-0834.

The voice unit module is used to perform the following functions:

Voice communication.

Systems equipped with voice unit modules enable remote communication from a room in which the nurse presence indicator has been turned on (green button of the display module).

- Pressing button H (Q) once only (fully illuminated) starts hands-free communication with the terminal from which the call is made;
- on pressing button H (Q) a second time (minimum illumination) the voice communication is interrupted.

If there is more than one call, with button A (A) it is possible to scroll through the list of these calls and select the one you want to answer.

Button E (E) lights up fully when a call is made to the room (for example via VOX) or when there is voice communication; in the case of voice communication piloted by the nurse, (E) lights up to indicate you can speak (voice unit module in transmission).

The "direction" in which the communication is made is indicated by the selfsame button (button E (E) on = speak; button E (E) off = listen).

The mode with which this communication is managed (full duplex/half duplex) is established by the device that triggers it:

- telephone coupler → always full duplex;
- voice → depending on the chosen configuration.

In the latter mode, the half duplex switching can take place in two ways:

- **Hands-free**, where the "direction" of the communication is established by the tone of voice; the exchange is made when the voice unit module recognizes a higher sound level of one speaker rather than the other. This type of solution is used in rooms that are not very noisy.

- **Push to talk**, where the communication exchange between the speakers takes place by pressing the button E (E) (press to speak, release to listen) by the health personnel present in the control room or in a room where assistance is being given; the switching is controlled by the terminal that requested the voice unit connection.

This type of application is used in noisy rooms.

Music transmission.

Connecting the system to an audio source, the voice unit modules enable transmitting

a music channel.

- Pressing button E (E) switches the music transmission on and off (the button is illuminated);
- pressing button F (F) lowers the volume;
- pressing button G (G) increases the volume.

Buttons E (E), F (F), G (G), and H (H) are backlit with a red light for location in the dark. When the voice or music channel is activated, the display will show the symbol  with the set volume level .

CONFIGURATION.

When first switched on the device must be configured manually, in following the configuration can be easily modified through the program Call-way dedicated or manually.

The configuration procedure allows the inclusion of the parameters needed to smooth operation.

MANUAL CONFIGURATION.

To carry out this type of activation it is necessary to connect the communication terminal 02080.AB.

With the display in resting conditions (in the absence of calls, presence, voice, etc.), press for more than 3 s the blue button (B) until the flashing of the respective blue led; then, while holding down the blue button (B) press for more than 3 s the yellow button (A) until the terminal enter the configuration phase and the display shows the firmware revision for 3 s.

For example:



where 05 and 'day, 02 month, 14 the last two digits of the year 01 and the firmware version.

Using the green (D) and red (A) buttons, set the ward number between 01 to 99 (button (A) (C) → decreases, button (D) (D) → increases) and confirm by pressing the yellow button (A).

When pressed, the buttons increase / decrease rapidly the number of department.



Using the green (D) and red (A) buttons, set the room number between 01 to 99 and between B0 to B9 (button (A) (C) → decreases, button (D) (D) → increases) and confirm by pressing the yellow button (A).

When pressed, the buttons increase/decrease rapidly the number of room.



If the room is configured between 1 and 99, the input configuration becomes by default: **Bed 1, Bed 2, Bed 3, Bathroom, Cancel Bathroom or Reset (depending on the following configurations).**

If the room is set up between B0 and B9, the input configuration becomes, by default: **Cabin 1, Cabin 2, Cabin 3, Cabin 4, Reset.**

Using the green (D) and red (A) buttons, set whether the terminal is for control (button (A) (C) → no, button (D) (D) → yes) and confirm by pressing the yellow button (A).



Using the green (D) and red (A) buttons, to set the inputs mode (NO, NC and disabled):

- by repeatedly pressing the button (A) (C) are selected cyclically inputs Ab1, Ab2, Ab3, Ab4, Ab5;
- by repeatedly pressing the button (D) (D) are selected cyclically mode NO, NC and -- (disabled).

Finally, confirm by pressing the yellow button (A).



Using the green (D) and red (C) buttons, whether or not to report a fault on the inputs (enable/disable detection release tail call).



- pressing button (C) will change the display:



- by repeatedly pressing the button (C) are selected cyclically inputs In1, In2, In3, In4, In5.

- pressing button (D) toggles between SI (YES) and no (SI = ignores release tail call, no = not ignore release tail call)

Finally, confirm by pressing the yellow button (A).

Using the green (D) and red (C) buttons, whether or not to report a fault on the lamps (enable/disable detection fault lamp).



- pressing button (C) will change the display:



- by repeatedly pressing the button (C) are selected cyclically lamps LP1, LP2, LP3, LP4.

- pressing button (D) toggles between SI (YES) and no (SI = ignores fault lamp, no = not ignore fault lamp).

Finally, confirm by pressing the yellow button (A).

Use the green (D) and red (C) buttons to set whether to enable the "CANCEL BATHROOM" function (button (C) = no, button (D) = SI):



NOTE: If the room was set up between B0 and B9 this point is omitted.

■ By selecting **Anb=SI** the bathroom call can only be RESET with the cancel button (art. 14504.AB) connected to the WCR input of the display module of the communication terminal 02080.AB.

■ By selecting **Anb=NO** the bathroom call can be RESET either with the cancel button (art. 14504.AB) or with the green button (D) of the display module of the communication terminal 02080.AB.

In its default setting, the CANCEL BATHROOM function is enabled.

Using the green (D) and red (C) buttons, set whether to enable the green button (D) (button (C) = not enabled, button (D) = enabled) and confirm by pressing the yellow button (A).



N.B. this point is omitted if the voice cancell bathroom setting it's SI; if you have enabled this option, it means that the green button (D) it's necessary to reset the call of Room and Bed and thus may NOT be disabled.

When the green button (D) is disabled, calls (room/bed and bathroom) are reset by means of the bathroom call cancelling button (art. 14504.AB) connected to the WCR input of the display module of the communication terminal 02080.AB

Using the green (D) and red (C) buttons, to set the inputs mode (NO, NC and disabled): the volume of the voice mode VDE-0834 between 0 to 15 (button (C) = decreases, button (D) = increases) and confirm by pressing the yellow button (A).



Using the green (D) and red (C) buttons, to set the communication mode of the audio by choosing between Push to talk Pt or Hand free HF (button (C) = Pt, button (D) = HF) and confirm by pressing the yellow button (A).



Using the green (D) and red (C) buttons, set the end of the call after the voice communication (button (C) = no, button (D) = YES) and confirm by pressing the yellow button (A).



Using the green (D) and red (C) buttons, to set if, in the event of a blackout, or not to enable the revival of their calls (button (C) = no, button (D) = SI) and confirm by pressing the yellow button (A).



Using the green (D) and red (C) buttons, to set variable rhythm of the buzzer mode choosing between traditional tr and VDE Ud (button (C) = tr, button (D) = Ud) and confirm by pressing the yellow button (A).



Using the green (D) and red (C) buttons, to set lamp operation mode choosing between VDE Ud and traditional tr (button (C) = tr, button (D) = Ud) and confirm by pressing the yellow button (A).



Using the green (D) and red (C) buttons, to set calls operation mode choosing between VDE Ud and traditional tr (button (C) = tr, button (D) = Ud) and confirm by pressing the yellow button (A).



Using the green (D) and red (C), push buttons, set whether to activate the "Tail call lead unhooked" signal (button (C) = SI, button (D) = no) and confirm by pressing the yellow button (A).



The configuration is now concluded and the communication terminal is operative.

INSTALLATION RULES.

Installation should be carried out by qualified staff in compliance with the current regulations regarding the installation of electrical equipment in the country where the products are installed. **Recommended installation height: from 1.5 m to 1.7 m.**

CONFORMITY.

EMC directive. Standards EN 60950-1, EN 61000-6-1, EN 61000-6-3.

REACH (EU) Regulation no. 1907/2006 – Art.33. The product may contain traces of lead.



WEEE - Information for users

If the crossed-out bin symbol appears on the equipment or packaging, this means the product must not be included with other general waste at the end of its working life. The user must take the worn product to a sorted waste center, or return it to the retailer when purchasing a new one. Products for disposal can be consigned free of charge (without any new purchase obligation) to retailers with a sales area of at least 400 m², if they measure less than 25 cm. An efficient sorted waste collection for the environmentally friendly disposal of the used device, or its subsequent recycling, helps avoid the potential negative effects on the environment and people's health, and encourages the re-use and/or recycling of the construction materials.