

Scatola da tavolo 8M - Table mounting box 8M - Boîte de table 8M - Caja de mesa 8M - Tischgehäuse 8M - Επιτραπέζιο κουτί 8M

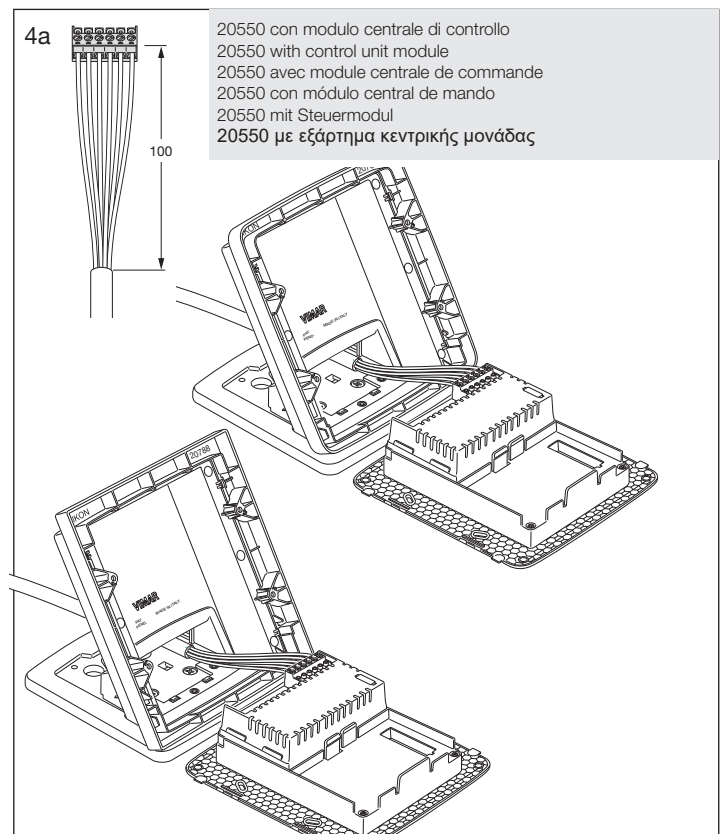

4b

20550 con modulo videocitofonico o 19558 o 19558.D
 20550 with video door entry module or 19558 or 19558.D
 20550 avec module vidéo-portier ou 19558 ou 19558.D
 20550 con módulo de videoportero o 19558 o 19558.D
 20550 mit Videosprecheinheit oder 19558 oder 19558.D
 20550 με εξάρτημα θυροτηλεόρασης ή 19558 ή 19558.D

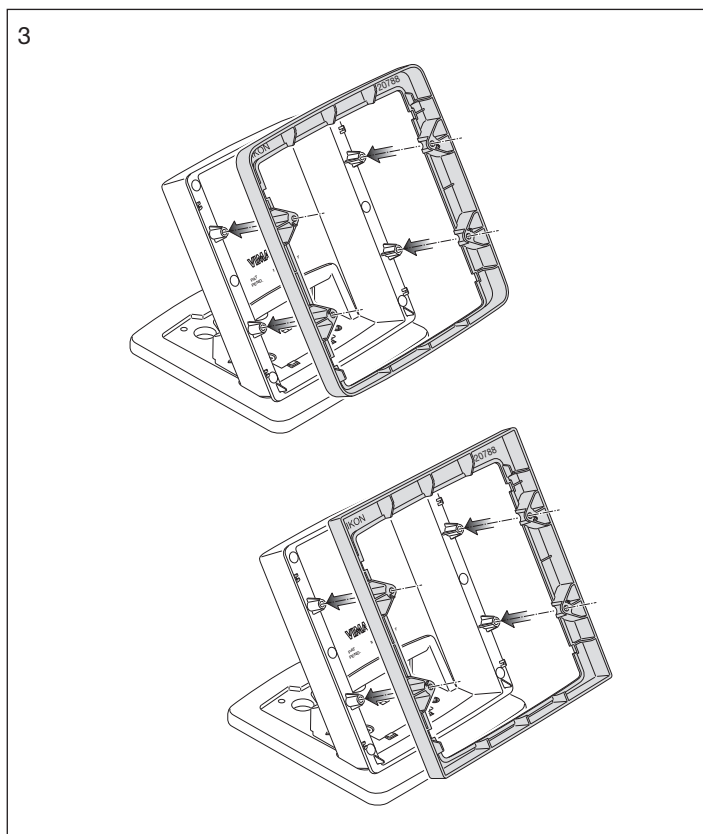
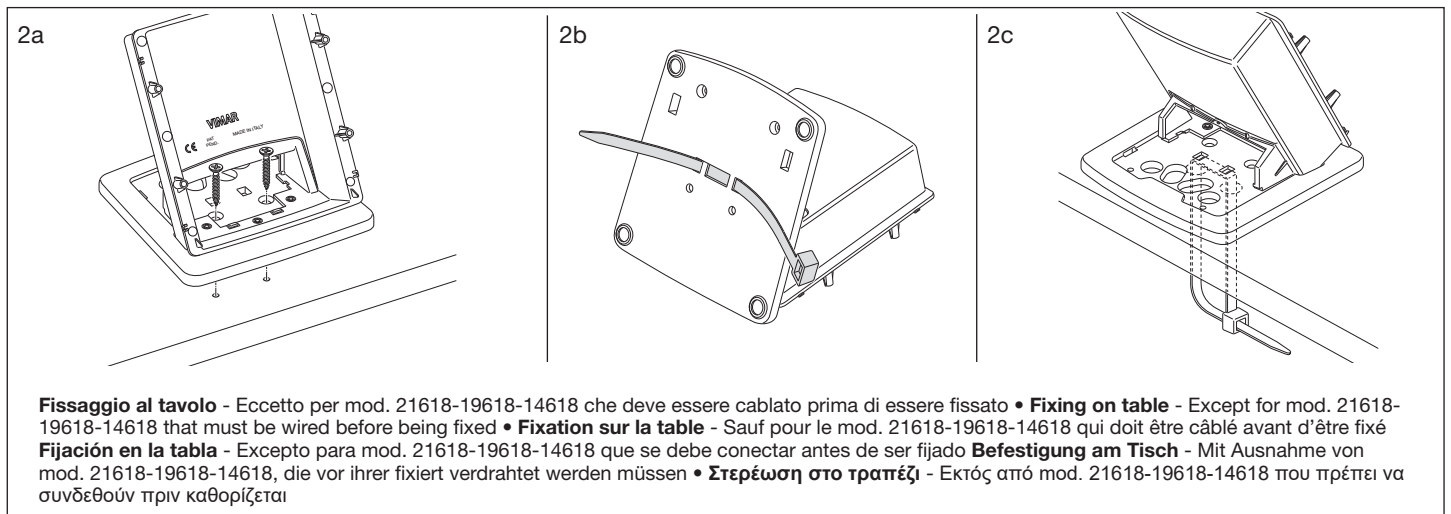
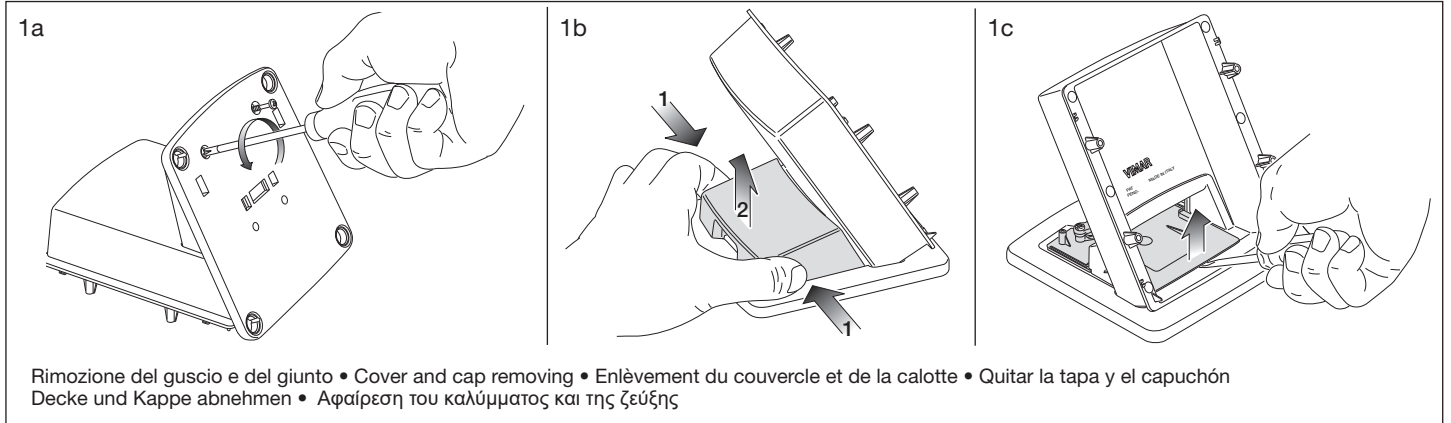
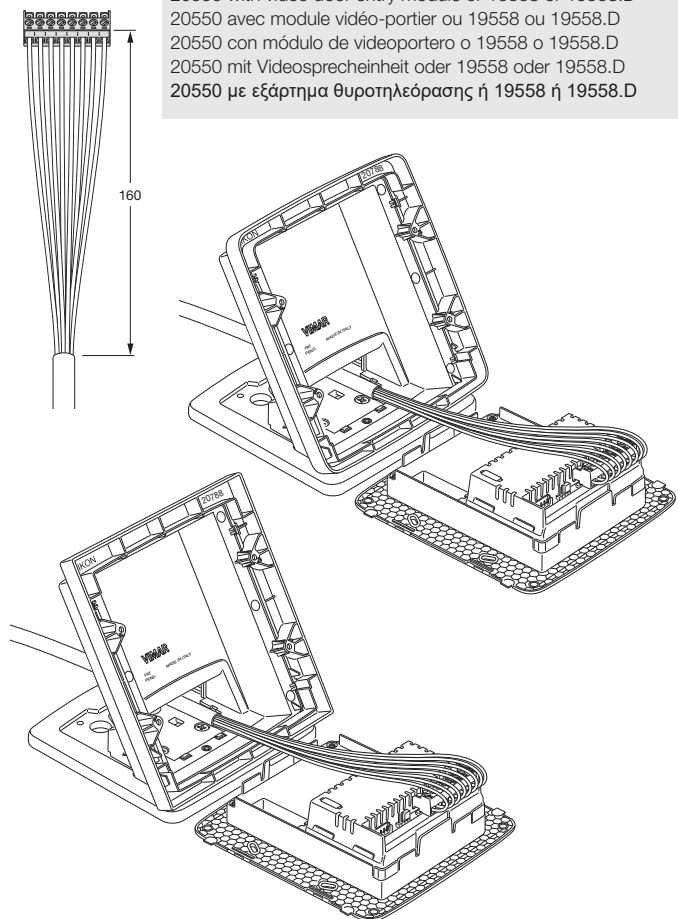

4c

21588

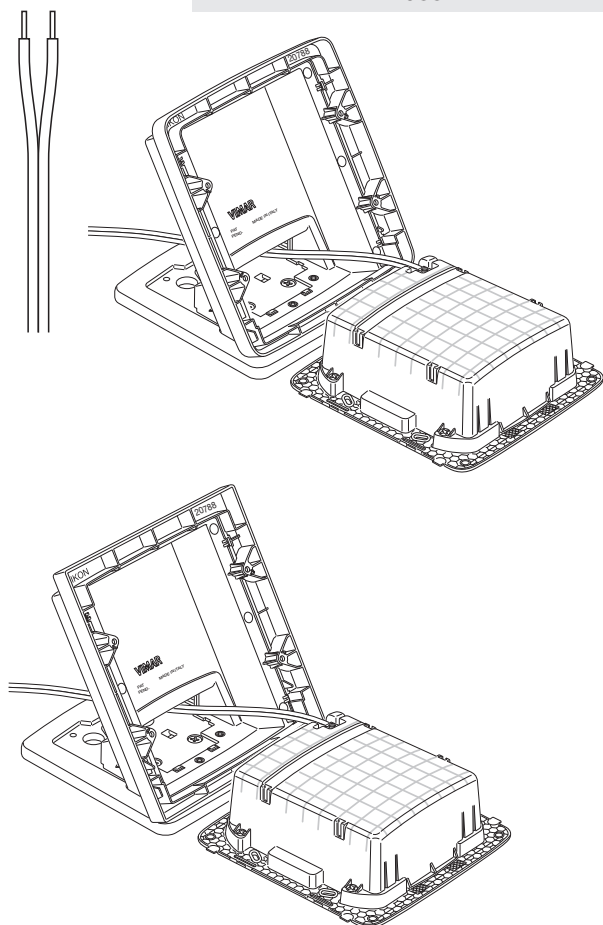

4d

21618-19618-14618

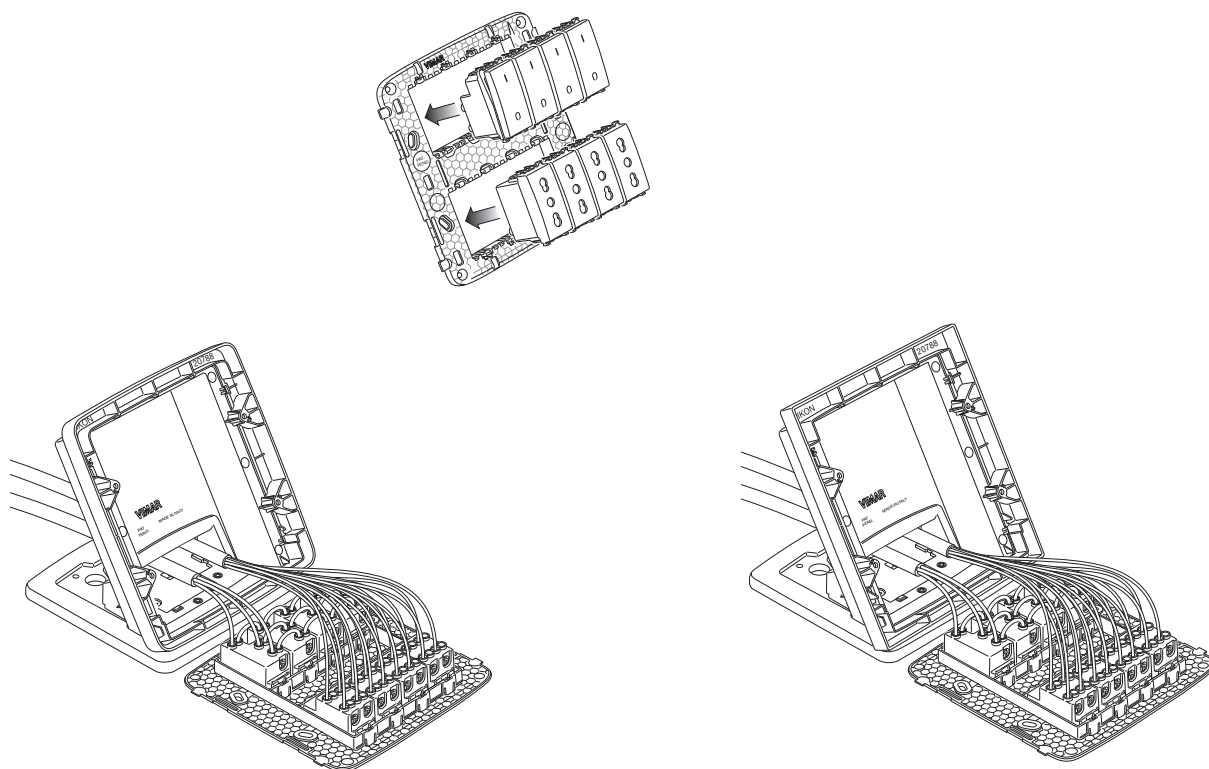

5a

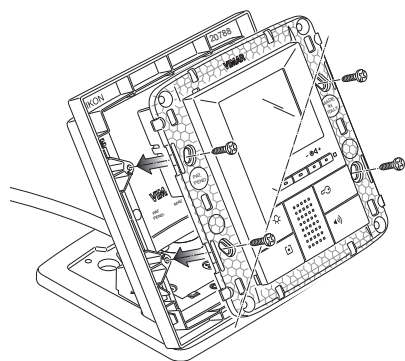
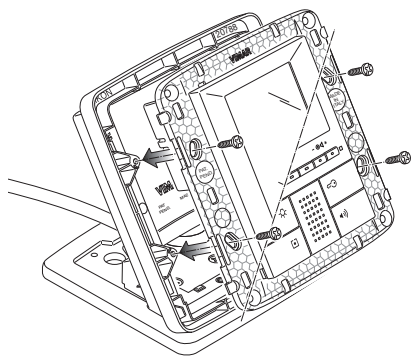

5b

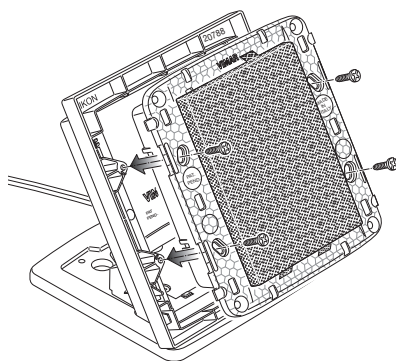
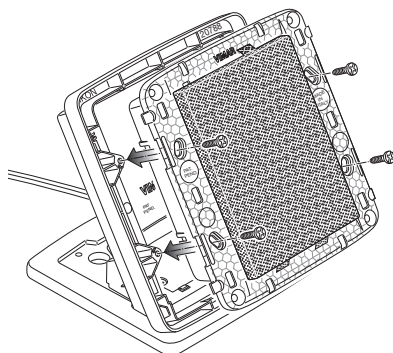

5c

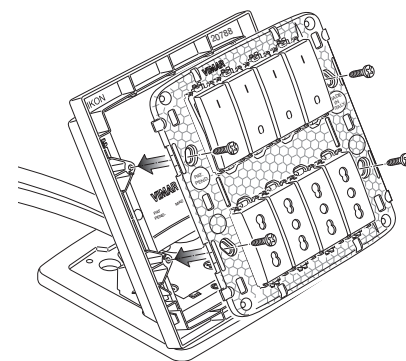
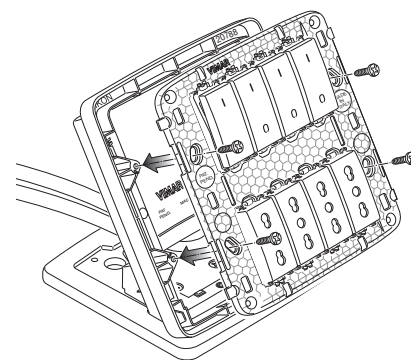

Attenzione: Utilizzare esclusivamente le viti fornite in dotazione • Attention: Use the supplied screws, only

Attention: Utiliser seulement les vis fournies • Atención: Emplear sólo tornillos suministrados

Wartung: Benutzen Sie nur die gelieferte Schrauben • Προσοχή : Χρησιμοποιήστε αποκλειστικά τις βίδες που υπάρχουν στην συσκευασία

6

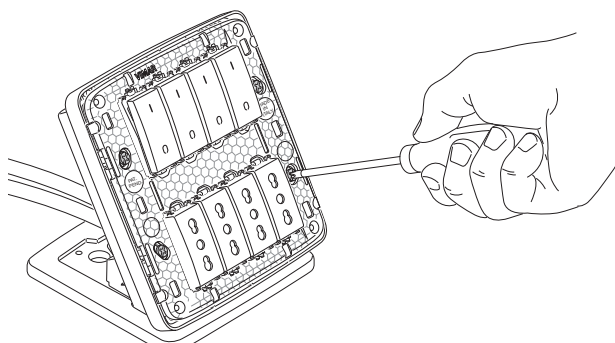
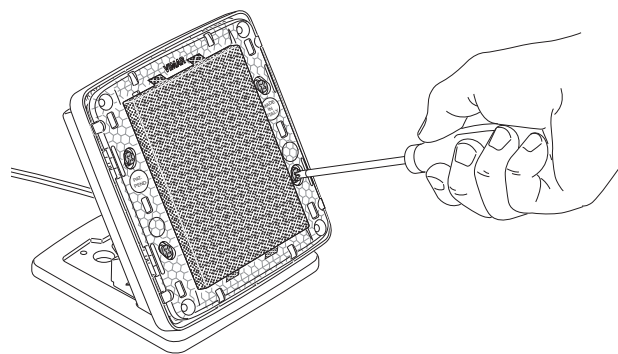
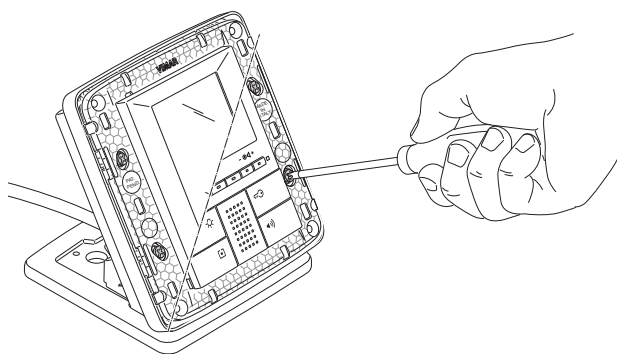

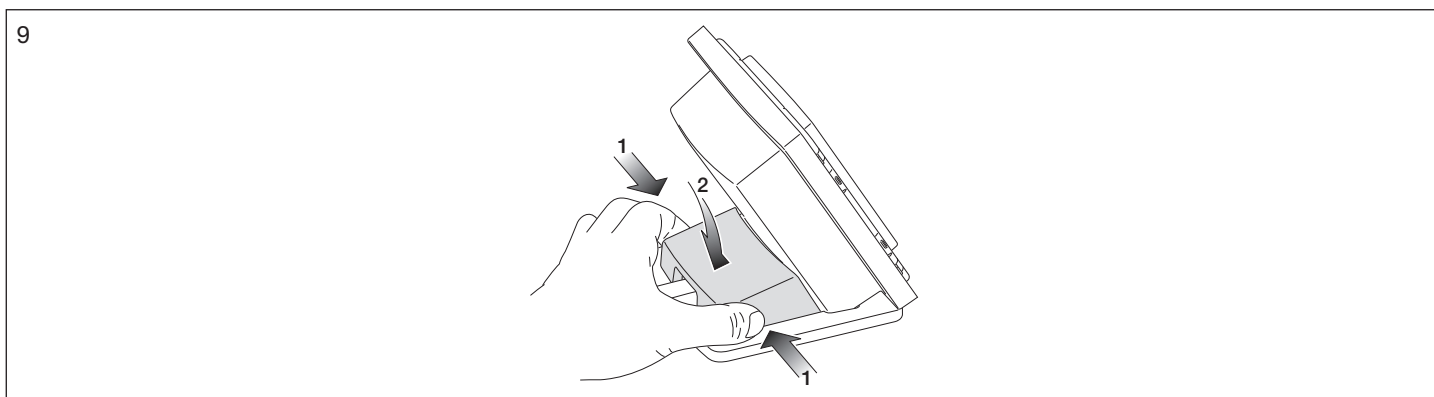
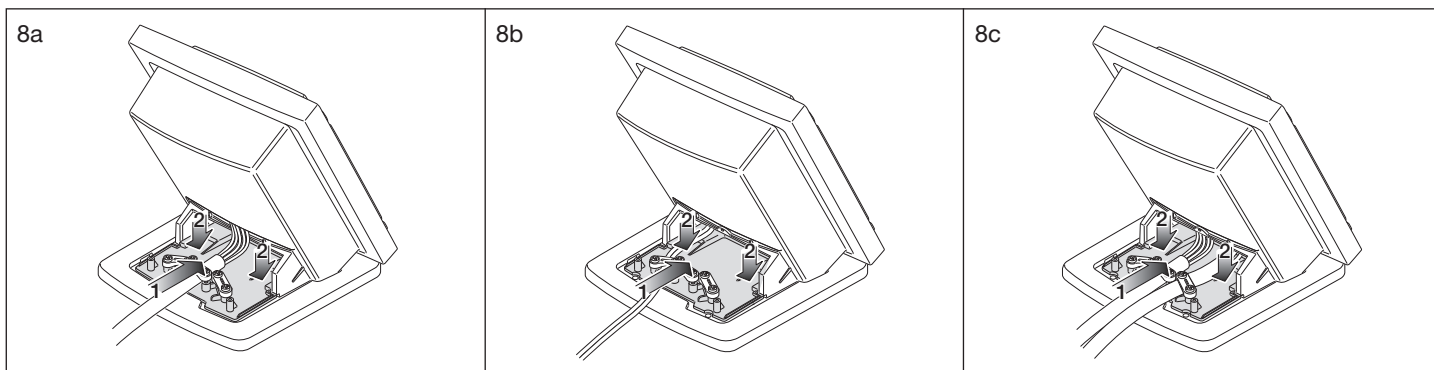
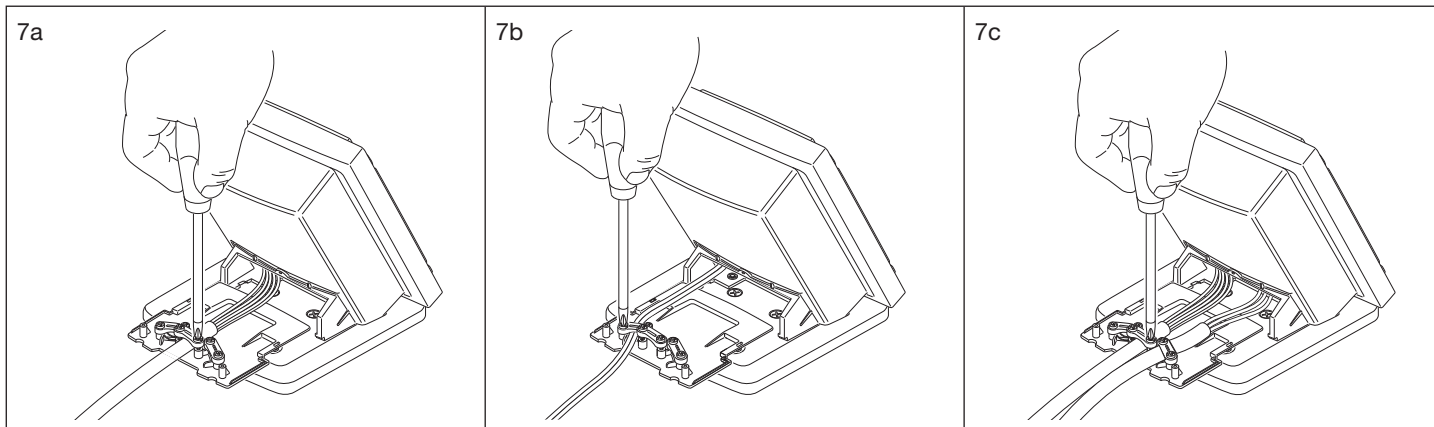

21618-19618-14618

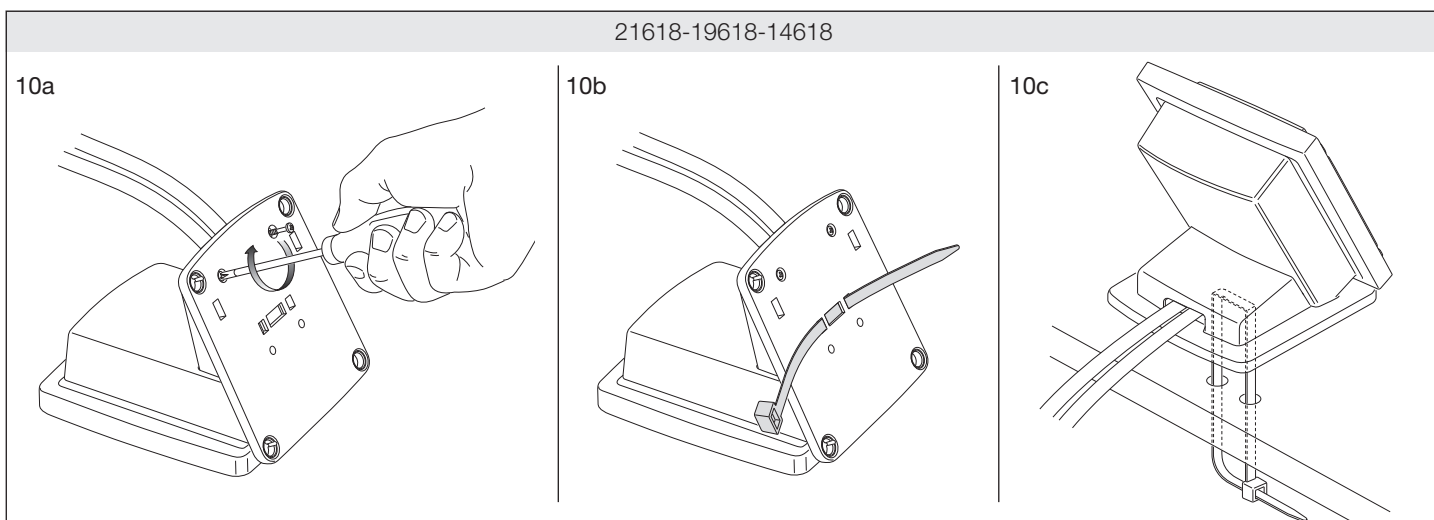

Soltanto per mod. 21618-19618-14618 - Il fissaggio al tavolo può essere effettuato soltanto con fascetta dopo il cablaggio e il fissaggio del guscio.

Only for mod. 21618-19618-14618 - The attachment to the table can be made only after the wiring and clamp securing the shell.

Seulement pour mod. 21618-19618-14618 - L'attachement à la table peut être effectué qu'après que le câblage et bride de fixation de la coquille.

Sólo para mod. 21618-19618-14618 - El apego a la mesa sólo puede hacerse después de que el cableado y la pinza que sujeta la cubierta.

Nur für mod. 21618-19618-14618 - Die Befestigung am Tisch kann erst nach der Verdrahtung und Klammer, die die Schale gemacht werden.

Μόνο για το mod. 21618-19618-14618 - Η προσκόλληση στο τραπέζι μπορεί να γίνει μόνο μετά την καλωδίωση και την εξασφάλιση της σφικτήρα κέλυφος.

11a

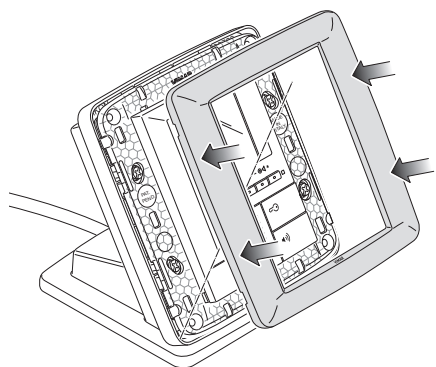

11b

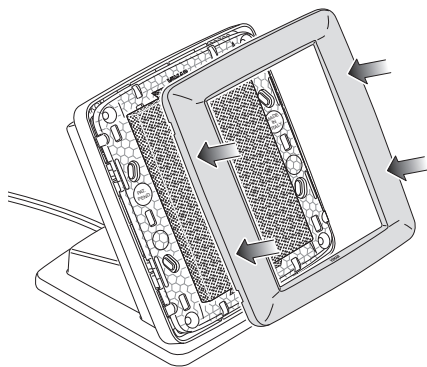

11c

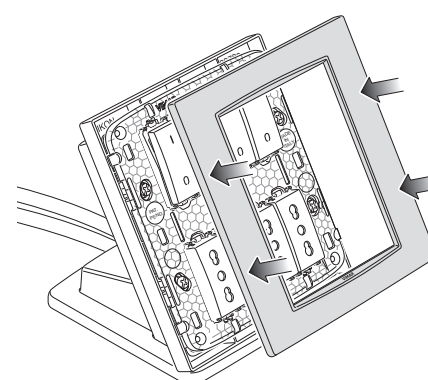
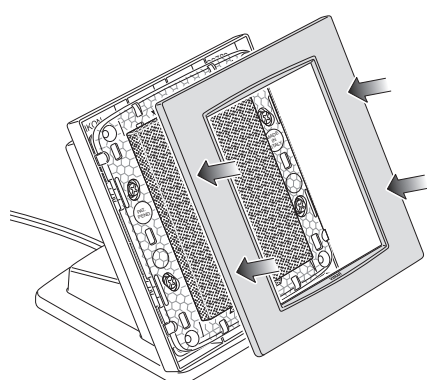
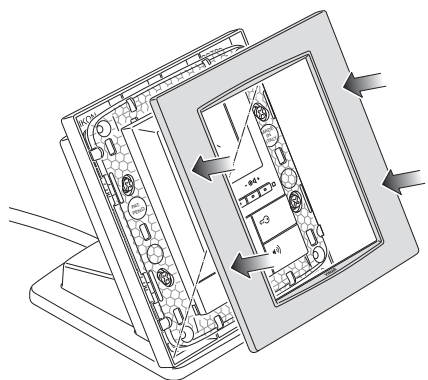
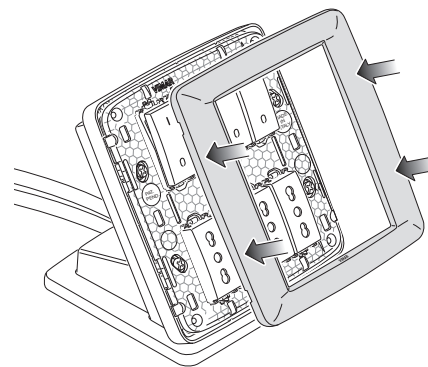

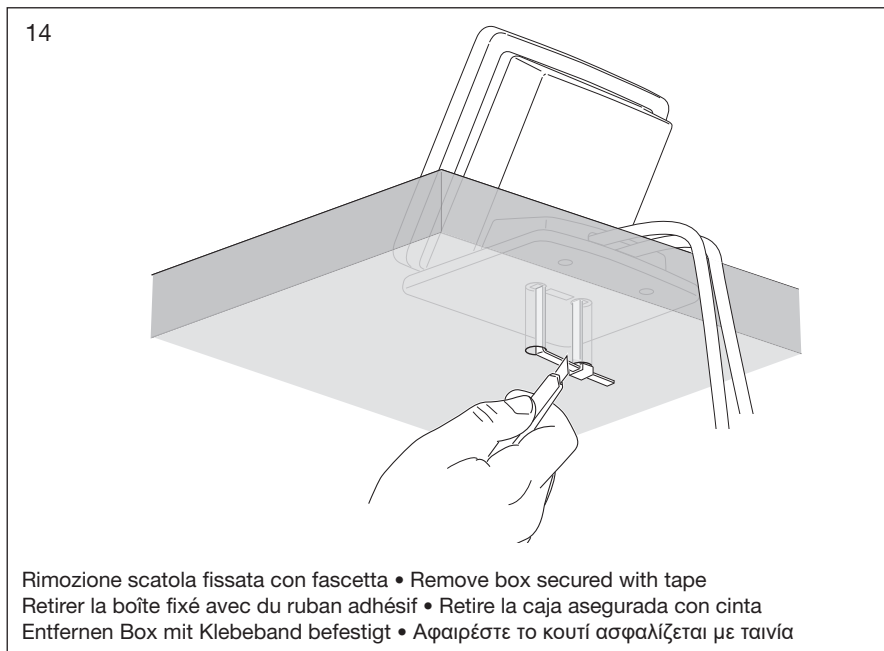
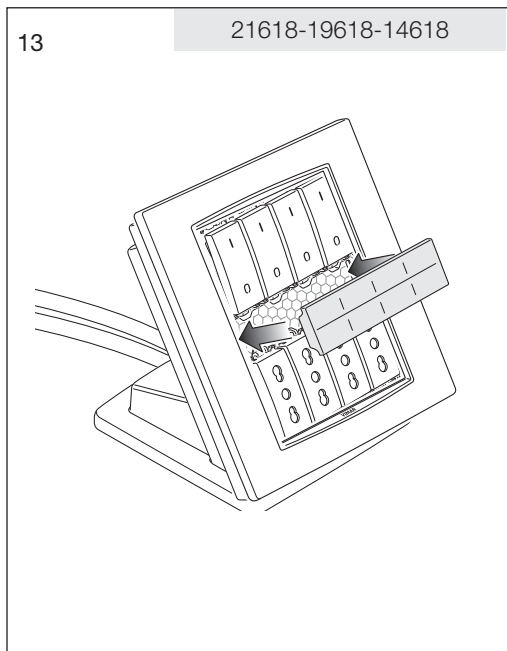

21618-19618-14618

