

03991  
03994

**03991 - Magnetic Quid relay module with sequential ON/OFF pulses, 1 input for NO push button, 1x10 AX 220-240 V~ 50/60 Hz relay output, installation in junction boxes or connector block boxes.**

**03994 - Magnetic Quid relay module with sequential ON/OFF pulses, 1 input for NO push button, 1x10 AX 220-240 V~ 50/60 Hz volt-free output, installation in junction boxes or connector block boxes.**

The device, which can be installed in connector block boxes and placed underneath the blank module or inside the junction boxes declared as suitable for electrical devices that dissipate energy, turns a load on or off following a signal received from a push button.

### CHARACTERISTICS.

- Rated supply voltage: 220 – 240 V~ 50/60 Hz.
- Max. 1 switching per second.
- Max 8 push buttons with coloured pilot lights 00936.250. wired in parallel with the NO control push button for visible in darkness function.
- It should be used in dry, dust-free places at a temperature of between 0 °C and +35 °C.
- Dissipated power: 1.5 W with load ON and max. current 10 A 0 W and no absorption with load OFF

#### • Art. 03991:

- ON/OFF control via NO push buttons.
- Relay output (1, L) for lights control 10 AX 220-240 V 50/60 Hz

#### • Art. 03994:

- ON/OFF control via NO push buttons wireable with respect to phase or neutral.
- Volt-free output.

### SUPPLEMENTARY DECLARATION MADE BY THE MANUFACTURER.

- Relay output (220- 240 V~ controllable loads):
  - rated load in AC1: 10 A (6.000 cycles);
  - rated load in AC15: 2.2 A (5.000 cycles);
  - resistive loads : 10 A (20.000 cycles);
  - incandescent lamps : 3 A (20.000 cycles);
  - fluorescent lamps : 100 W (20.000 cycles);
  - energy saving lamps : 100 W (20.000 cycles);
  - LED lamps : 100 W (20.000 cycles);
  - electronic transformers : 2 A (20.000 cycles);
  - power supply units for LED strips: 200 W (20.000 cycles).

### INSTALLATION RULES.

- Installation must be carried out by qualified persons in compliance with the current regulations regarding the installation of electrical equipment in the country where the products are installed.
- The power supply circuit (L-N) must be protected against overloads by installing a device, fuse or automatic 1-way switch, with a rated current not exceeding 10 A.
- Since these are retrofit devices, art. 03991 and 03994 must always be installed in protected boxes.

### REGULATORY COMPLIANCE.

LV Directive. EMC directive. EN 60669-2-1 standard.

REACH (EU) Regulation no. 1907/2006 – Art.33. The product may contain traces of lead.

#### WEEE - User information

The crossed bin symbol on the appliance or on its packaging indicates that the product at the end of its life must be collected separately from other waste. The user must therefore hand the equipment at the end of its life cycle over to the appropriate municipal centres for the differentiated collection of electrical and electronic waste. As an alternative to independent management, you can deliver the equipment you want to dispose of free of charge to the distributor when purchasing a new appliance of an equivalent type. You can also deliver electronic products to be disposed of that are smaller than 25 cm for free, with no obligation to purchase, to electronics distributors with a sales area of at least 400 m<sup>2</sup>. Proper sorted waste collection for subsequent recycling, processing and environmentally conscious disposal of the old equipment helps to prevent any possible negative impact on the environment and human health while promoting the practice of reusing and/or recycling materials used in manufacture.

#### FRONT VIEW

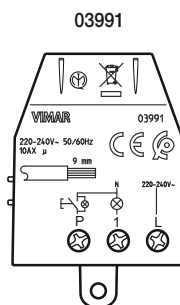

P = ON/OFF push button input  
1 = Load Output  
L = Line

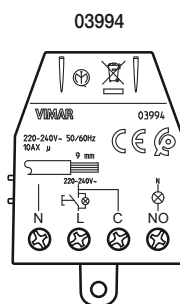

N: input for ON/OFF push button wired with respect to neutral (terminal L should be connected directly to phase).  
L: input for ON/OFF push button wired with respect to phase (terminal N should be connected directly to neutral).  
C: common to be connected to phase  
NO: Volt-free output normally open.

#### CONNECTION OF VISIBLE IN DARKNESS PUSH BUTTON FOR 03991 AND 03994

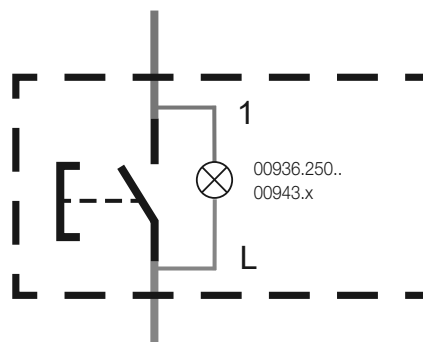

When pressing the control push button, the visible in darkness pilot light switches off.

### 03991 CONNECTIONS

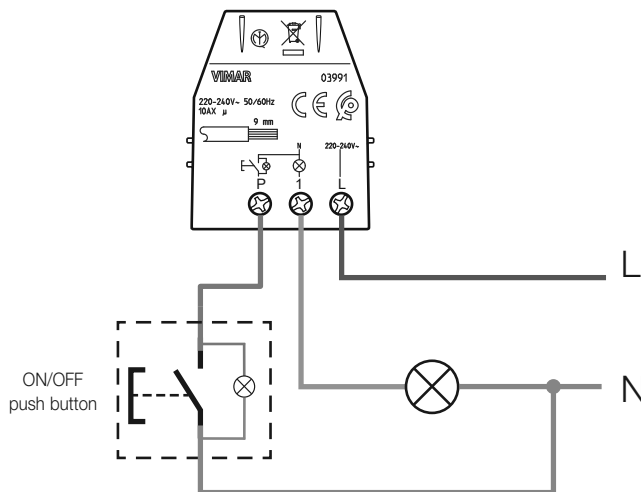

### 03994 CONNECTIONS

Connection example with NO control push button wired to L

Connection example with NO control push button wired to N

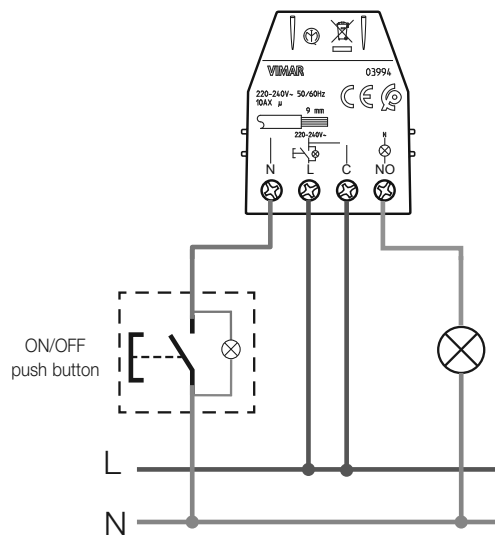
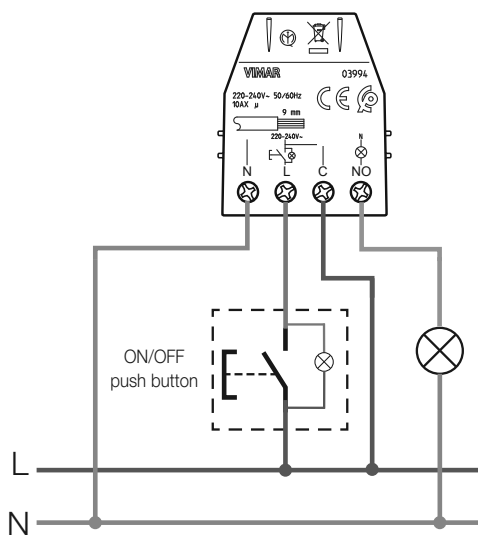

#### QUID DEVICES

	03991	Silent module for ON/OFF; push button wiring on N
	03992	Silent module for ON/OFF and centralised ON/OFF of lights
	03993	Silent module for ON/OFF with 2 sequential outputs
	03994	Silent module for ON/OFF; push button wiring on N or L
	xx196	Flush mounting switch for centralised management of roller shutters
	03996	Module for centralised management of roller shutters
	03997	Module for roller shutter group management