

Installer manual



**01560**

Touch screen KNX in color

---

**Focus on the treatment of the following:**

- (1) Under the process of software upgrade, interrupting the power supply may cause the system to fail to start;
- (2) Under the process of using MicroSD card to modify the background picture, electronic photo album picture, home page icon and multifunctional page icon, the power supply may be interrupted, which may cause the system fail to start;
- (3) Make sure that the MicroSD card is completely empty before the card is inserted, that is, no data with embedded system firmware is burned, otherwise the system may be damaged;
- (4) If the power supply needs to be interrupted after modifying the setting information, it is recommended that the power can be cut off after 6 seconds when complete modifying, otherwise the modification may not be successful;
- (5) If the auxiliary power supply is power off when the screen is on, the screen may display with a tiny flashing after the power recovery in the next time. At this case, let the device continuously power on for a period of time (maximum around half an hour), the screen will automatically recover to the normal display state.

In the above (1) and (2) cases, the device need to return to the factory for maintenance, please be careful to deal with.

Index

<b>1. Summary</b> .....	5
<b>2. Technical Data</b> .....	5
<b>3. Dimension and Structural Diagram</b> .....	6
3.1 Dimension diagram .....	6
3.2 Structural Diagram .....	7
3.3 Installation and Disassembly instructions .....	8
3.3.1 Vertical installation and disassembly instructions .....	8
3.3.2 Horizontal installation and disassembly instructions .....	11
<b>4. After finishing the installation, if disassembly is required, please perform this step:</b> .....	14
<b>5. Parameter setting description in the ETS</b> .....	15
5.1 Parameter window "General" .....	15
5.1.1 Parameter window "General setting" .....	15
5.1.2 Parameter window "Coordinates location setting" .....	19
5.1.3 Parameter window "Screensaver display setting" .....	20
5.1.4 Parameter window "Summer time setting" .....	22
5.1.5 Parameter window "Colourful strip setting" .....	23
5.1.6 Parameter window "Proximity setting" .....	26
5.1.7 Parameter window "Password setting" .....	27
5.1.8 Parameter window "Alarm setting" .....	28
5.1.9 Parameter window "Advanced setting" .....	30
5.2 Parameter window "Home page" .....	30
5.2.1 Parameter window "Home page setting" .....	30
5.2.2 Parameter window "Home page x" .....	32
5.3 Parameter window "Function Page" .....	34
5.3.1 Parameter window "Multifunction" .....	35
5.3.2 Parameter window "Room temperature control" .....	39
5.3.2.1 Parameter window "Fan" .....	45
5.3.2.2 Parameter window "Setpoint" .....	46
5.3.2.3 Parameter window "Heating/Cooling control" .....	49
5.3.3 Parameter window "Air conditioner" .....	53
5.3.3.1 Parameter window "Mode" .....	55
5.3.3.2 Parameter window "Fan" .....	56
5.3.3.3 Parameter window "Vanes swing" .....	57
5.3.4 Parameter window "Audio control" .....	58
5.3.5 Parameter window "Colour and colour temperature control" .....	60
5.3.6 Parameter window "Air Quality display" .....	62
5.3.7 Parameter window "Floor heating" .....	65
5.3.7.1 Parameter window "Scene" .....	67
5.3.8 Parameter window "Ventilation System" .....	69
5.3.8.1 Parameter window "Fan" .....	70
5.3.8.2 Parameter window "Scene" .....	72
5.3.8.3 Parameter window "Fan auto control" .....	73
5.3.9 Parameter window "Energy Metering display" .....	76
5.4 Parameter window "Internal temperature measurement" .....	77
5.5 Parameter window "Human Centric Lighting (HCL)" .....	79
5.6 Parameter window "Weekly timer function" .....	79
5.6.1 Parameter window "Time x" .....	82
5.7 Parameter window "Scene Group function" .....	83
5.8 Parameter window "Logic function" .....	85
5.8.1 Parameter window "AND/OR/XOR" .....	86
5.8.2 Parameter window "Gate forwarding" .....	88
5.8.3 Parameter window "Threshold comparator" .....	89
5.8.4 Parameter window "Format convert" .....	90
5.8.5 Parameter window "Delay function" .....	91
5.8.6 Parameter window "Staircase lighting" .....	92
<b>6. Description of Communication Object</b> .....	93
6.1 "General" Communication Object .....	93
6.2 "Home page" Communication Object .....	95
6.3 "Function Page" communication object .....	95
6.3.1 "Multifunction (Lighting/Blind/Scene/Value send)" Communication Object .....	95
6.3.2 "Room temperature control" Communication Object .....	99
6.3.3 "Air conditioner" Communication Object .....	103
6.3.4 "Audio control" Communication Object .....	105
6.3.5 "Colour and colour temperature control" Communication Object .....	106
6.3.6 "Air Quality display" Communication Object .....	109
6.3.7 "Floor heating" Communication Object .....	110
6.3.8 "Ventilation System" Communication Object .....	111
6.3.9 "Energy Metering display" Communication Object .....	112

**Index**

---

6.4 “Internal temperature measurement” Communication Object .....	113
6.5 “Human Centric Lighting(HCL)” Communication Object .....	114
6.6 “Weekly timer function” Communication Object .....	115
6.7 “Scene Group function” Communication Object .....	115
6.8 “Logic function” Communication Object .....	116
6.8.1 “AND/OR/XOR” Communication Object .....	116
6.8.2 “Gate forwarding” Communication Object .....	116
6.8.3 “Threshold comparator” Communication Object .....	117
6.8.4 “Format convert” Communication Object .....	117
6.8.5 “Delay function” Communication Object .....	119
6.8.6 “Staircase lighting” Communication Object .....	120



## Summary - Technical Data

### 1. Summary

KNX Smart Touch series product, are used to display status and control a variety of KNX devices, by touching the icons in the interface to perform the preset function. Such as sending switch command, scene command, blind, Air conditioner control command to bus system, control other devices on the bus.

Compare to common button panel, KNX Smart Touch series product display pictures and makes buzzer indication through LCD, and can be easily and clearly operated through the friendly interaction interface.

KNX Smart Touch series product are mainly applied in the home and building control system, wall-mounted installation, which can be mounted on a conventional 80 or 86 junction boxes. This product is not only suitable for Chinese-Standard and European-Standard, but also for American-Standard. Details for installation and removal instruction refer to section 3.3.

This manual provides specific technical information about KNX Smart Touch series product for users, as well as assembly and programming details, and explains how to use the Touch Panel by the application examples.

KNX Smart Touch series product powered from KNX bus, and need a 24-30V DC auxiliary supply voltage. It is available to assign the physical address and configure the parameters by engineering design tools ETS with .knxprod ( support edition ETS5.7 or higher ).

The functions of KNX Smart Touch series product are summarized as followed:

- 5 inch colour IPS, 480x854 resolution, capacitive touch screen
- Support vertical or horizontal display via ETS
- With switching, dimming, curtains control, scene, value send and switch indicator
- Room temperature control
- Air conditioner
- Audio control
- RGB, RGBW, RGBCW control and colour temperature setting
- Ventilation system control and Floor heating control
- Display air quality detected value
- Display energy metering value
- Weekly timer function
- Scene group function
- Logic function, support AND, OR, XOR, logic gate forwarding, threshold comparator, conversion of different data types
- Home page navigation function
- Alarm function, Internal temperature sensor
- Human Centric Lighting (HCL)
- Display time, date, temperature and humidity, output day/night signal
- Proximity sensor, adjustment of screen brightness, colourful strip, vibration feedback when touch
- Password function, screen-saver function(clock, album or disable) and panel lock function

### 2. Technical Data

Power Supply	Bus voltage	21-30V DC, via KNX bus
	Bus current	6mA/24V DC, 5mA/30V DC
	Bus consumption	< 150mW
Auxiliary supply	Voltage	24-30V DC
	Current	< 125mA/24V DC, <100mA/30V DC
	Consumption	< 3W
Connections	KNX	Bus connection terminal
	Auxiliary supply	KNX auxiliary connection terminal
Temperature	Operation	-5 °C ... + 45 °C
	Storage	-25 °C ... + 55 °C
	Transport	- 25 °C ... + 70 °C
Environment	Humidity	<93%, except for dewing
Proximity sensor	Approximately 30 cm <b>Note: This distance is obtained based on human detection, not an obstruction.</b>	
Installation	Wall-mounted installation, install the metal plate onto the 80 or 86 junction box firstly, and then install the device into metal plate.	
Size	86 x 148.8 x 11.5 mm	
Weight	0.3 kg	

3. Dimension and Structural Diagram

3.1 Dimension diagram

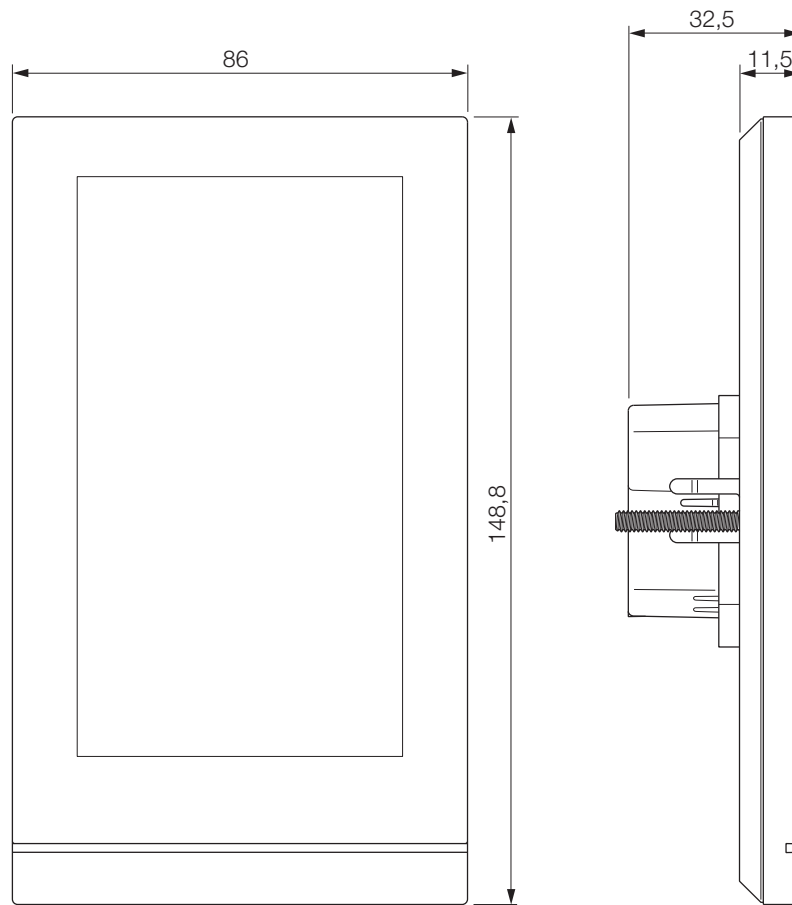

Panel dimension

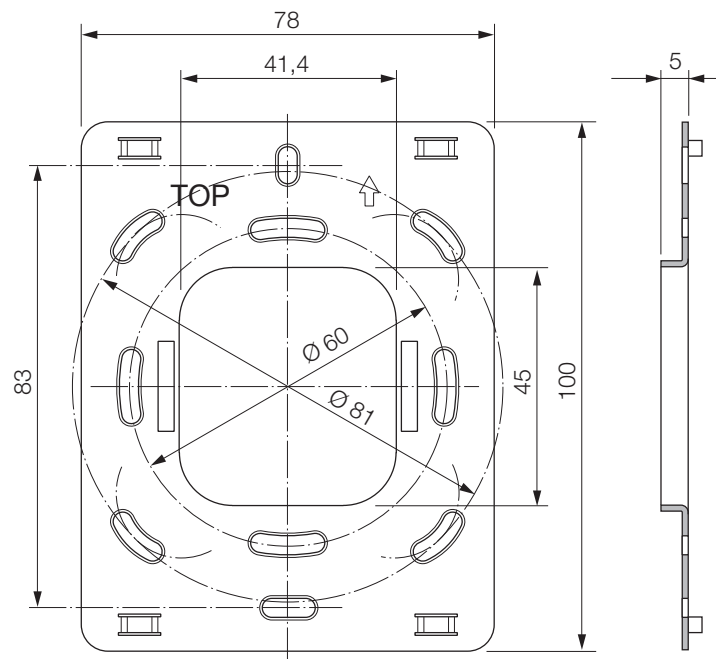

Metal plate dimension

3.2 Structural Diagram

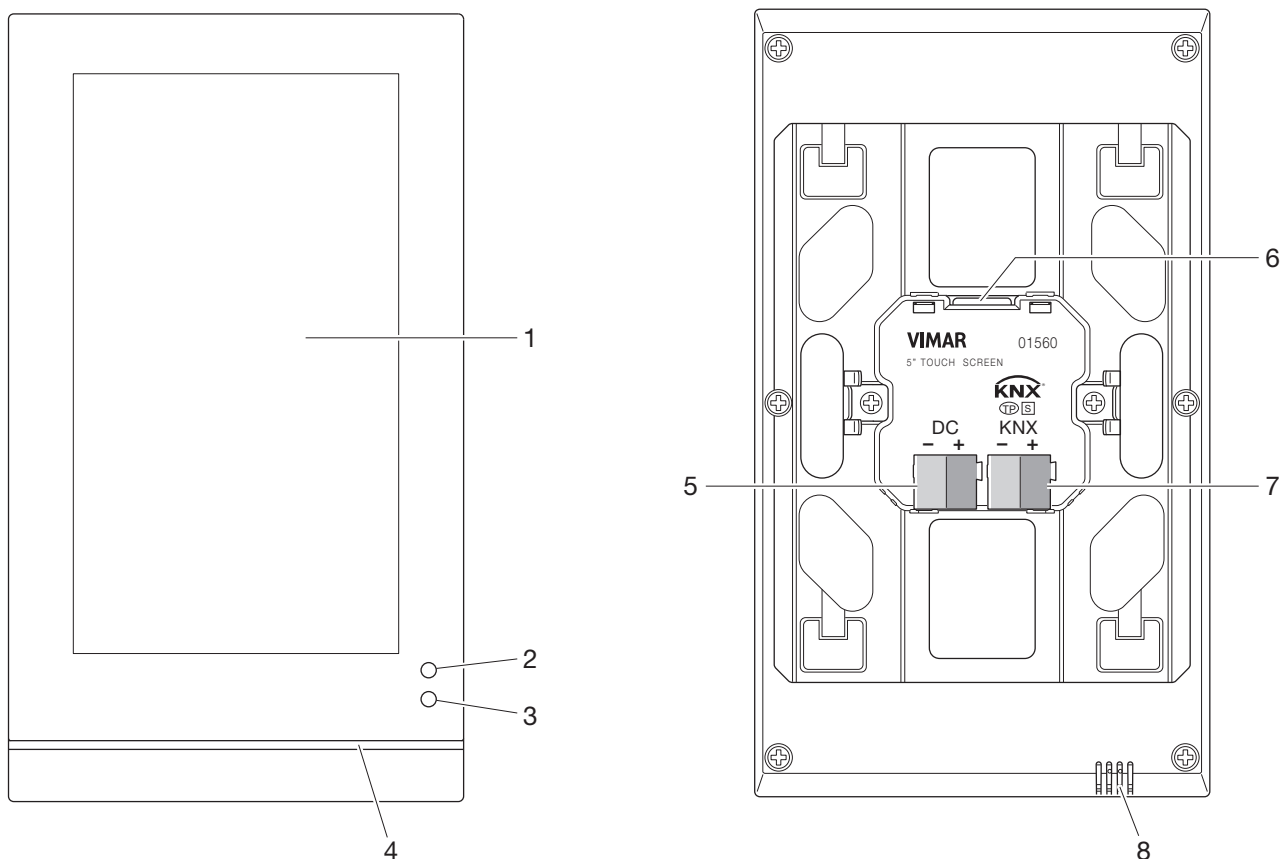

Structural diagram

- 1 Touch and display area
- 2 - 3 Proximity sensor
- 4 Colorful strip
- 5 Auxiliary supply connection terminal
- 6 SD card slot
- 7 KNX bus connection terminal
- 8 Internal temperature sensor

**Note:**

The programming of the physical address needs to be entered into the setting interface of the screen. Click the icon on the screen to enter the setting interface, then click "General para." to enter the general parameter setting interface. Here you can set "KNX programming" item, and turn the programming mode on or off via the switch button on the right. When the programming mode is turned on, the Colorful strip lights red. After exiting the programming mode, the Colorful strip returns to the indication that is configured via parameters.

### 3.3 Installation and Disassembly instructions

#### 3.3.1 Vertical installation and disassembly instructions

##### 1. Install metal plate to the junction box on the wall with mounting screws.

Installation specification:

- (1) It is suggested that Junction box should be parallel with the wall horizon, shown as Fig. 3.3.1.1;
- (2) The upper direction is defined where marks with arrow and "TOP" description on the metal plate;
- (3) Screwdriver should not drive too strong when installed, otherwise it will result in the deformation of the metal plate. The recommended strength is 0.6~0.8N.M (6~8 Kgf.cm);
- (4) Fixed metal plate screws use M4 special screws matched by our company.

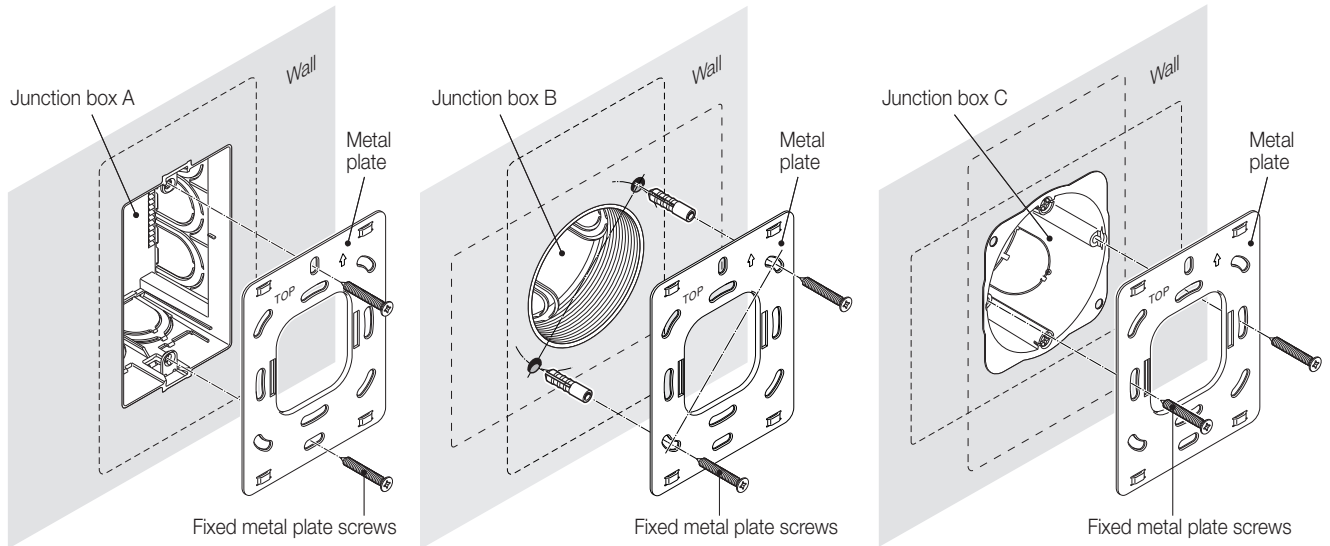

Fig.3.3.1.1

##### 2. Remove the connection terminal on the device and connect it correctly according to the wiring instructions. After wiring, install the terminal to the corresponding position, then the wiring installation is finished, as shown in Fig. 3.3.1.2.

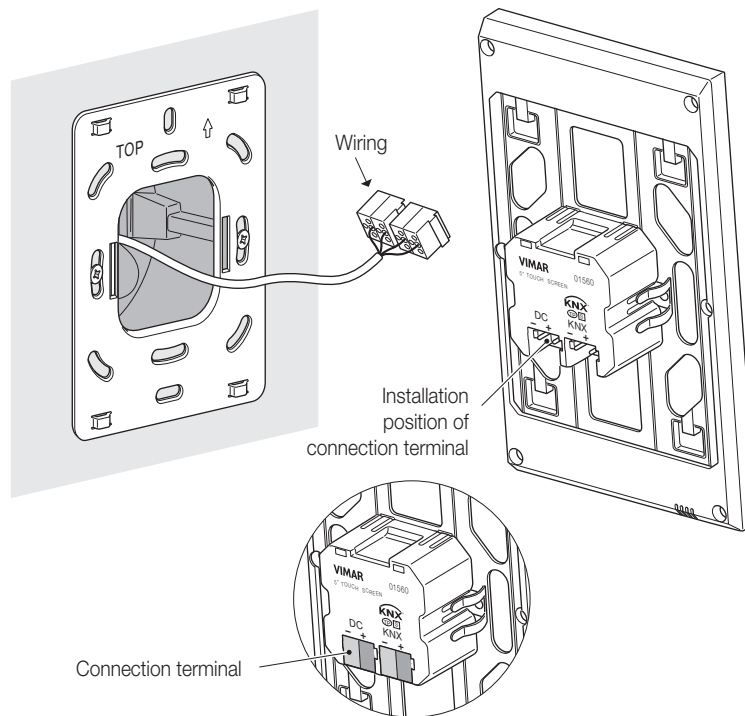

Fig. 3.3.1.2

## Dimension and Structural Diagram

### 3. After connection of the device complete:

- (1) Action 1: Align the back of the device to the mounting hole position of the metal plate, requiring the device to be parallel to the wall or the metal plate;
- (2) Action 2: The upper plane of the bulge on the back of the device is aligned to the upper plane of the hole position of the metal plate, and attention should be paid to the shrapnel installation hole of the metal plate. See Fig. 3.3.1.3 and Fig. 3.3.1.4.
- (3) Action 3: After finishing action 1 and action 2, press the device down and tighten it (Fig. 3.3.1.4), then the installation is finished.

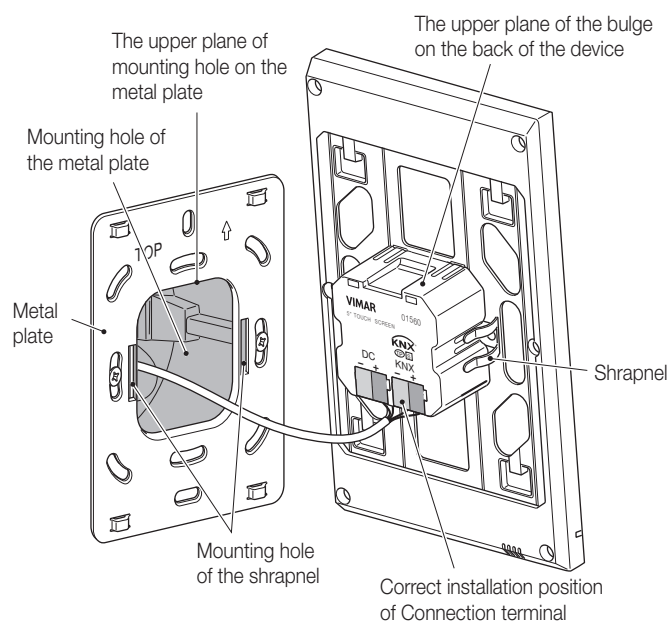

Fig. 3.3.1.3

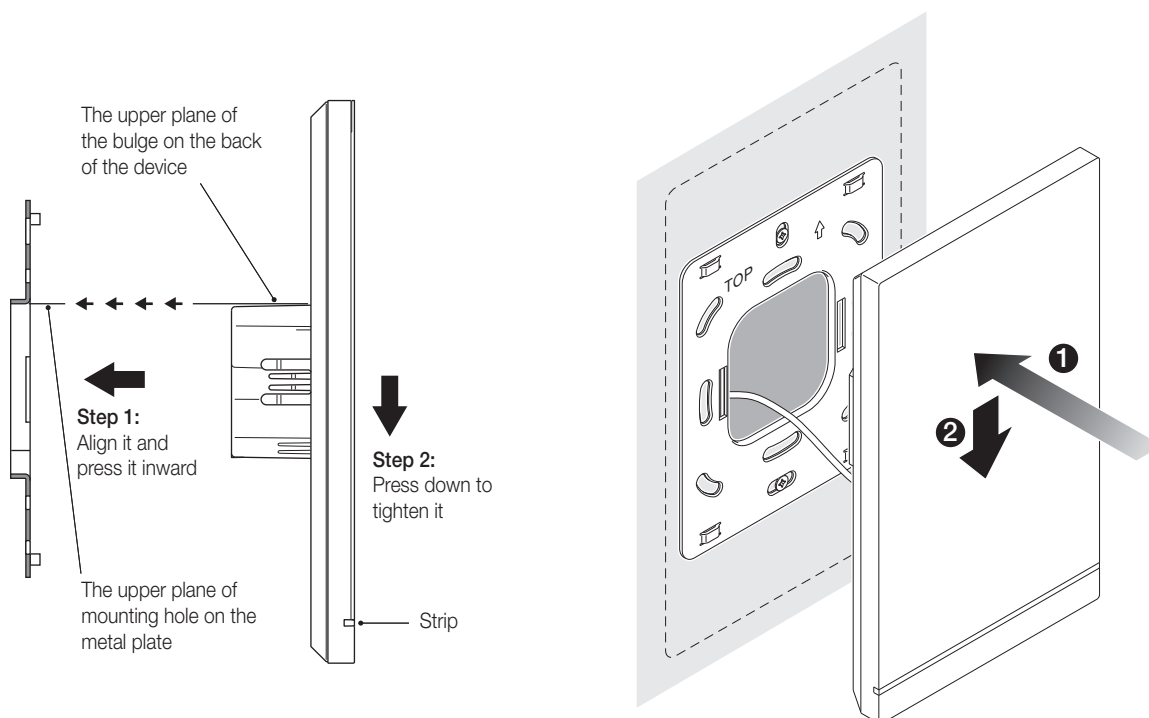

Fig. 3.3.1.4

Dimension and Structural Diagram

4. After finishing the installation, if disassembly is required, please perform this step:

Push the device upward, then pull it out toward the horizontal direction when hear a buckle sound or when the device can no longer be moved, then the disassembly is finished. As shown in Fig. 3.3.1.5. The disassembly of SD card as shown in Fig. 3.3.1.6

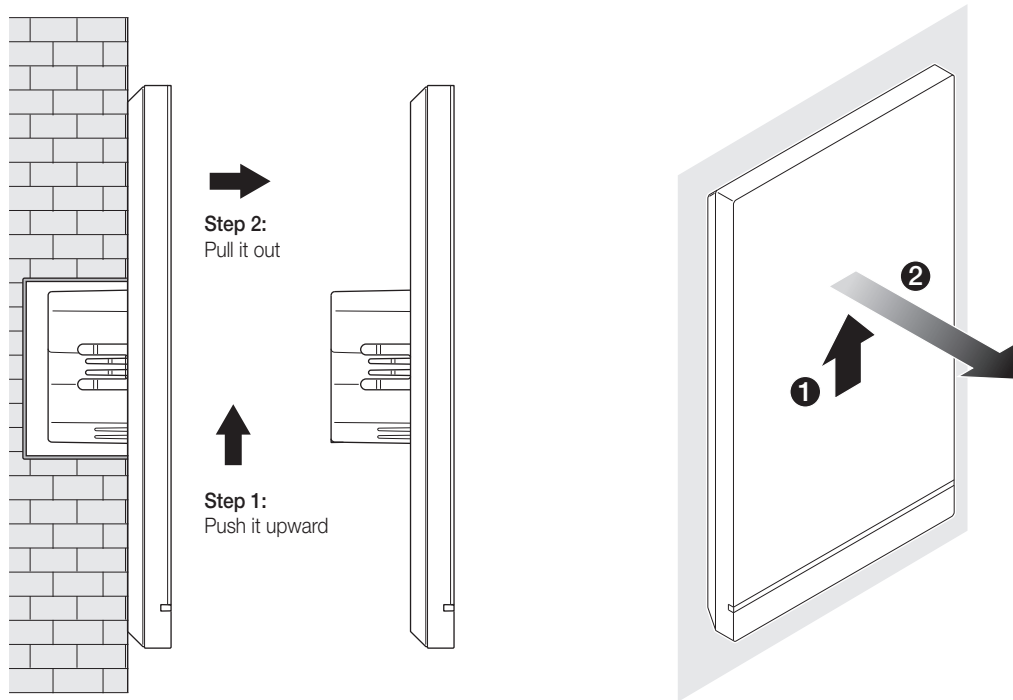

Fig. 3.3.1.5

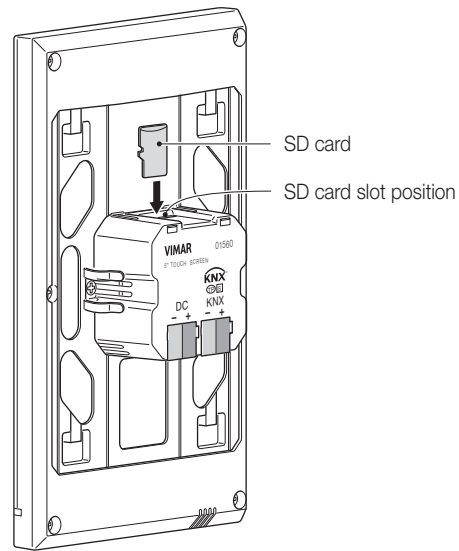

Fig. 3.3.1.6

### 3.3.2 Horizontal installation and disassembly instructions

#### 1. Install metal plate to the junction box on the wall with mounting screws.

Installation specification:

- (1) It is suggested that Junction box should be parallel with the wall horizon, shown as Fig. 3.3.2.1;
- (2) The reference direction is defined where marks with arrow and "TOP" description on the metal plate is treated as the left side;
- (3) Screwdriver should not drive too strong when installed, otherwise it will result in the deformation of the metal plate. The recommended strength is 0.6~0.8N.M(6~8Kgf.cm);
- (4) Fixed metal plate screws use M4 special screws matched by our company.

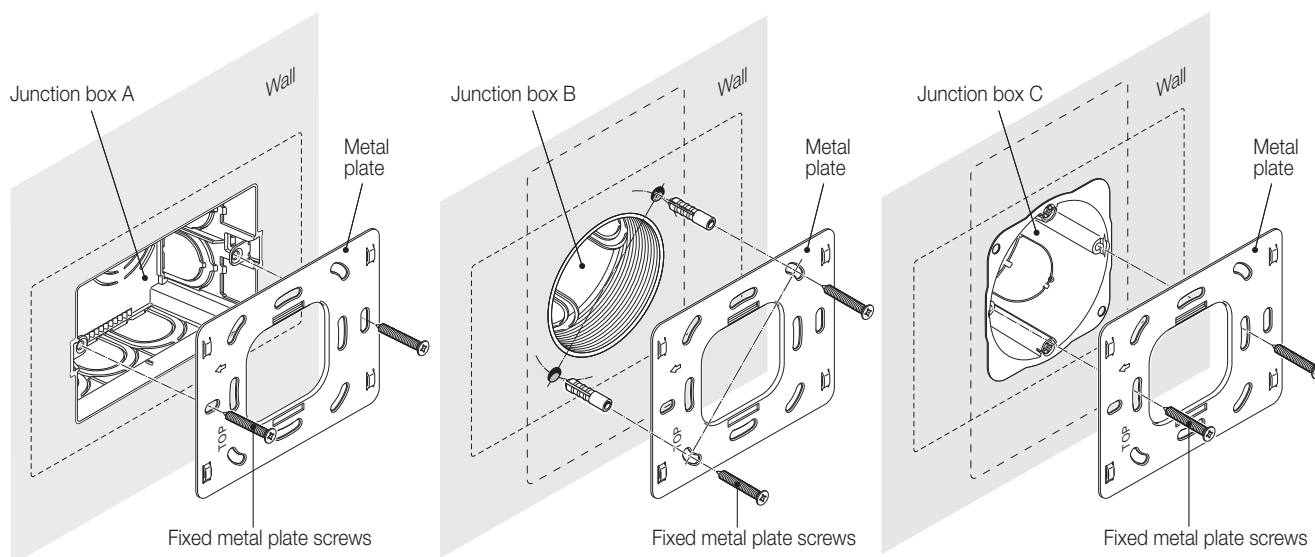

Fig. 3.3.2.1

2. (1) Remove the connection terminal on the device and connect it correctly according to the wiring instructions. After wiring, install the terminal to the corresponding position, then the wiring installation is finished, as shown in Fig. 3.3.2.2.
- (2) Note that the metal edge is on the right side of people when the panel is installed.

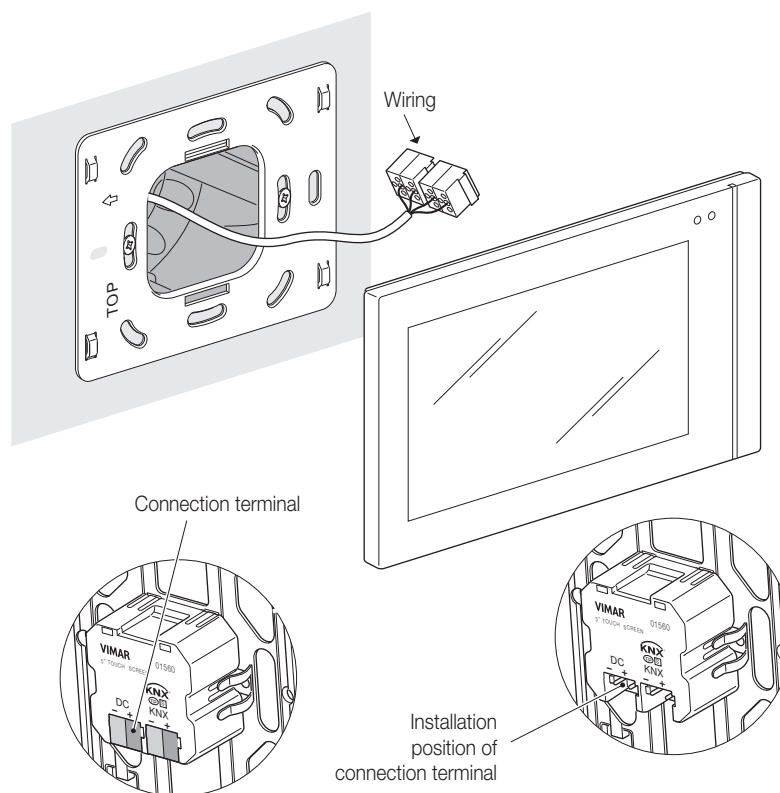

Fig. 3.3.2.2

## Dimension and Structural Diagram

3. After connection of the device complete:

- (1) Action 1: Align the back of the device to the mounting hole position of the metal plate, requiring the device to be parallel to the wall or the metal plate;
- (2) Action 2: The left plane of the bulge on the back of the device is aligned to the left plane of the metal plate (Top side), and attention should be paid to the shrapnel installation hole of the metal plate. See Fig. 3.3.2.3 and Fig. 3.3.2.4(1) - 3.3.2.4(2).
- (3) Action 3: After finishing action 1 and action 2, press the device to the right side of people and tighten it (Fig. 3.3.2.4(1) - 3.3.2.4(2)), then the installation is finished.

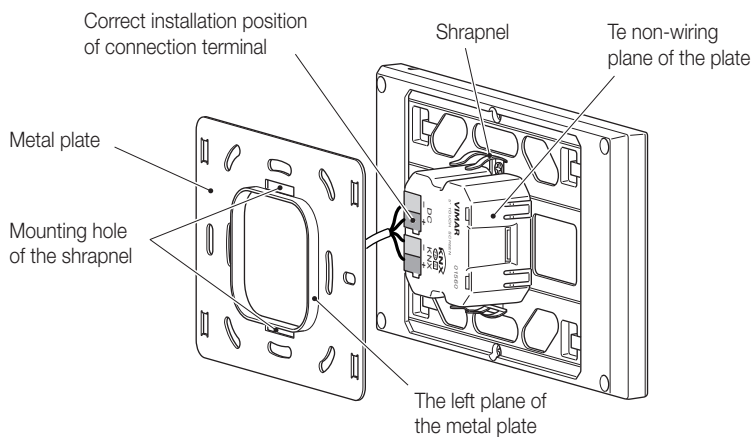

Fig. 3.3.2.3

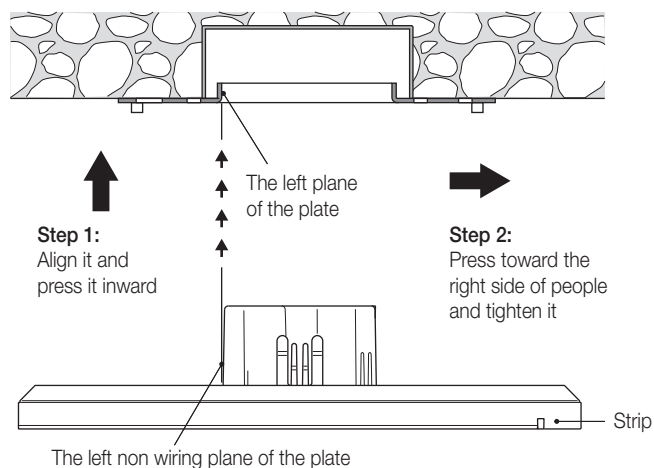

Fig. 3.3.2.4(1)

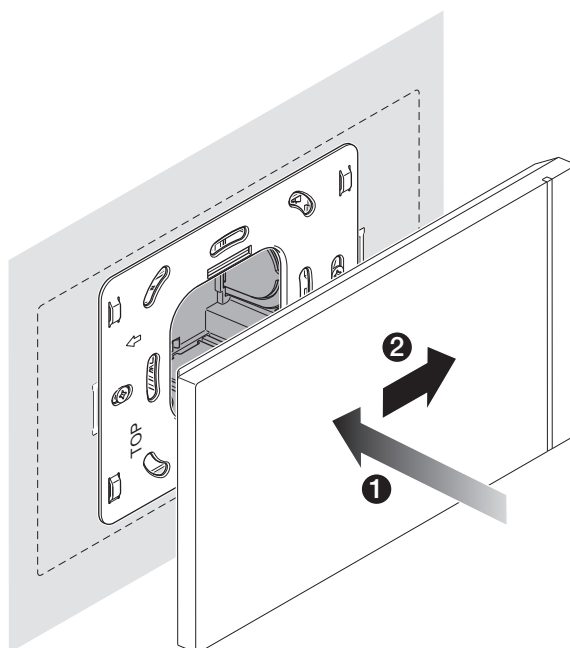

Fig. 3.3.2.4(2)



## Dimension and Structural Diagram

4. After finishing the installation, if disassembly is required, please perform this step:

Push the device to the left side of people, then pull it out to the front direction of people when hear a buckle sound or when the device can no longer be moved, then the disassembly is finished.

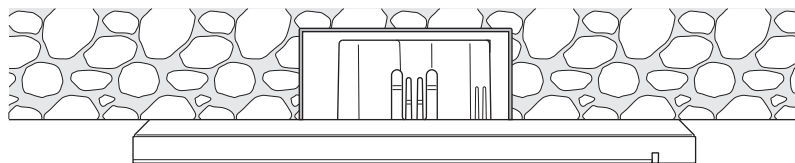

 **Step 1:**  
Press toward the  
left side of people

 **Step 2:**  
Pull it out

Fig. 3.3.2.5 (1)

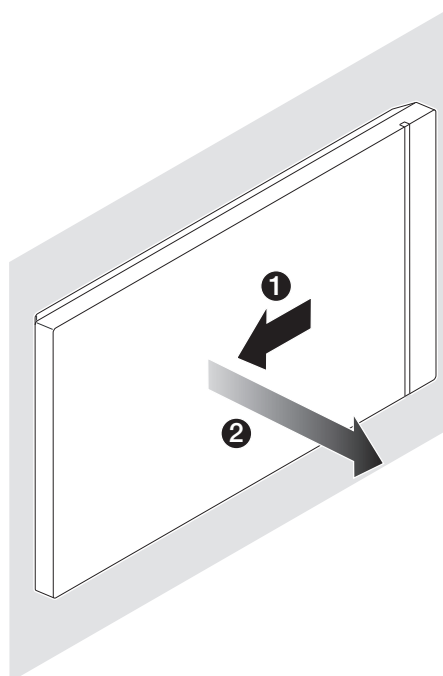

Fig. 3.3.2.5 (2)

## After finishing the installation, if disassembly is required, please perform this step:

### 4. After finishing the installation, if disassembly is required, please perform this step:

Push the device to the left side of people, then pull it out to the front direction of people when hear a buckle sound or when the device can no longer be moved, then the disassembly is finished.

Maximum of communications objects	Maximum number of group addresses	Maximum number of associations
948	2000	2000

#### General function

General function include system interface language selection, operation tones, panel lock, screen saver, screen backlight brightness adjustment, colourful strip indication setting, proximity sensor setting, summer time setting, date/time display, alarm setting, etc.

Besides, user can configure screen background dark or light, the UI style of multifunction page, and to send the status of day/night mode.

#### Homepage Navigation Function

On the homepage, user can configure function-page navigation buttons to quickly jump to the function page, and can also configure icon in multifunction page navigation to quickly perform one of the functions.

#### Lighting Control

It is mainly used for switching lighting equipment or dimming lighting equipment. Dimming mode can be relative dimming, brightness dimming, relative+brightness dimming or brightness+colour temperature dimming. And the colour temperature dimming is optional to normal control or directly control.

#### Curtain and blind control

To control open/close curtain, roller blind and venetian blind. Support to adjust the position and slat.

#### Value sender function

Values of different data types can be sent.

#### Switch indicator

To indicate the switch status of lighting device or other device.

#### Scene control

Short operation for the scene recall, long operation for the scene storage.

#### Room temperature control function

RTC is mainly used to control the room temperature, automatically and optimally control the heating and cooling according to the use of the room or the needs of the occupants. Supports manually switching of heating/cooling control, support options for three-level fan speed and auto

#### Air conditioner control

Air conditioner control is suitable for VRV/VRF system, needs to be controlled with the KNX to VRV/VRF air-conditioner gateway, support to the control function, including power on/off, setpoint temperature, mode, fan speed, vanes swing, timer, etc.

#### Audio control

It is used to control background music playing, for example, power on/off, play/pause, previous song/next song, volume increase/decrease, mute, play modes, track name, artist name, album name, and so on.

#### RGB dimming and colour temperature

It is mainly used for RGB, RGBW and RGBCW LED dimming in absolute dimming way. RGBCW supports RGB lighting, colour temperature and brightness adjustment. And the colour temperature dimming is optional to normal control or directly control.

#### Air quality detected value display

Temperature, humidity, PM2.5, PM10, VOC, CO2, AQI, brightness, wind speed and rain status displays can be set and these values are received from external sensor.

Up to 4 items can be set in a function page.

#### Floor heating control

Supporting 2-point control and PI control to automatically switch floor heating according to temperature difference. In addition, it supports to the scene and timer functions configuration and the setting temperature range adjustment.

#### Ventilation system control

Supporting 3-level fan speed adjustment, opening/closing of heat recovery, filter life counter, filter overtime alarm and filter reset.

Auto control according to the concentration of PM2.5 or CO2, in addition to setting scene function.

#### Energy metering value display

Support current, voltage, power and energy (electricity energy) display configuration, these values are received from other actuators or metering gateway.

#### Human Centric Lighting (HCL)

Set up a lighting environment that makes people feel comfortable, adjust brightness and colour temperature automatically according to the setting time.

#### Weekly timer function

Supporting to timely send different types of value, 01560 provides up to 16 timing controls. When enable time function, weekly timer of the setting interface is operational. In this interface, user can enable/disable weekly timer and holiday function setting, time function is automatically disabled during holiday. In addition, weekly timer can be disabled through the bus.

#### Scene group function

By calling the scene number, up to eight output telegrams can be triggered. Each output has three different data type options. There are 8 sets of scene functions available for setting

#### Logic function

Up to support 8 channels of logic, each channel up to support 8 inputs and 1 logic result.

Logic function support functions, including AND, OR, XOR, Gate forwarding, Threshold comparator, Format convert, Delay function and Staircase lighting.

## Parameter setting description in the ETS

### 5. Parameter setting description in the ETS

#### 5.1 Parameter window “General”

##### 5.1.1 Parameter window “General setting”

Parameter window “General setting” shown as Fig. 5.1.1, it is mainly for the general setting of the device, such as summer time setting, password setting, colourful strip indication setting, proximity setting, screen saver, panel lock and background, etc.

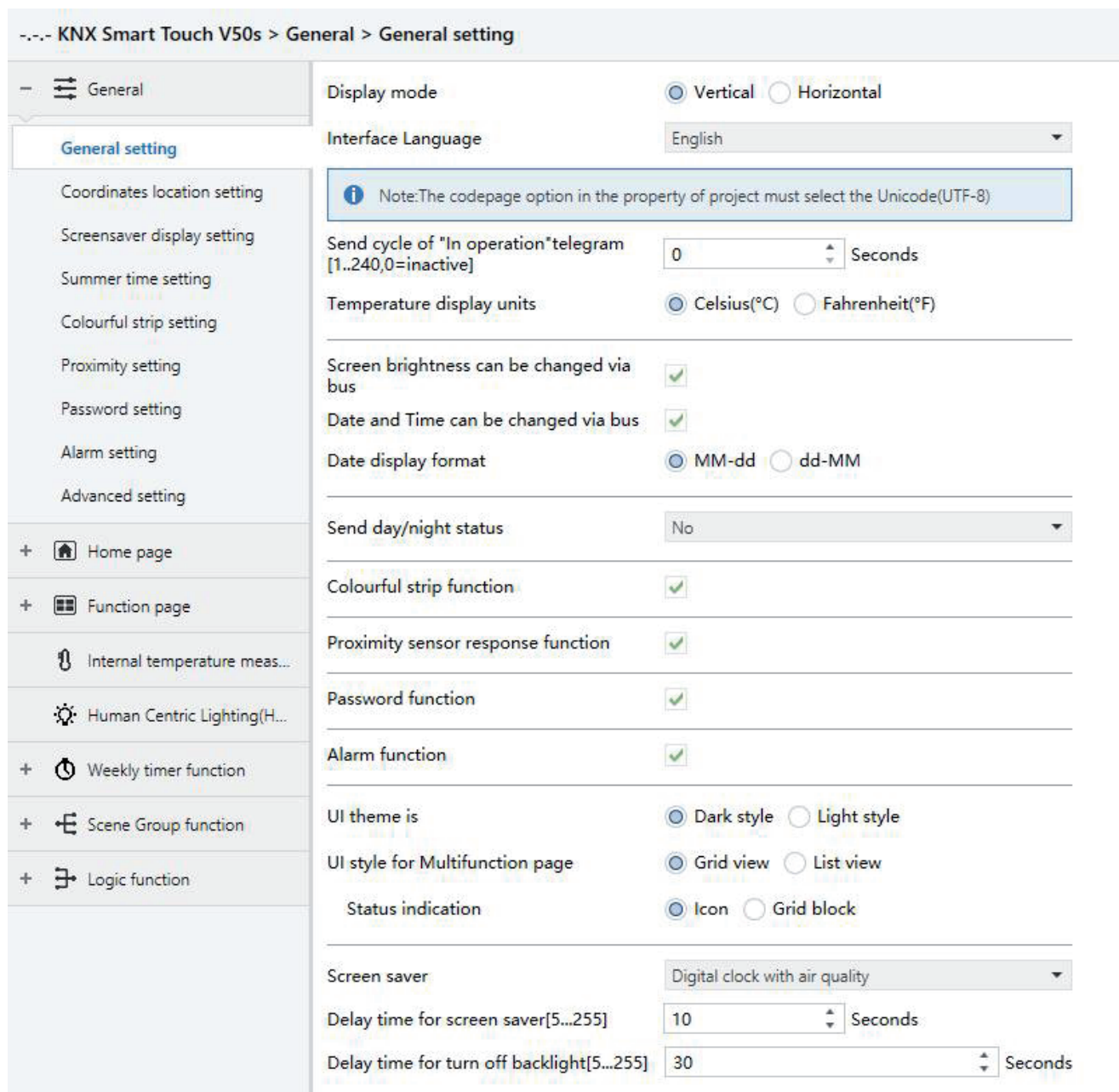

Fig. 5.1.1(1) “General setting” parameter window

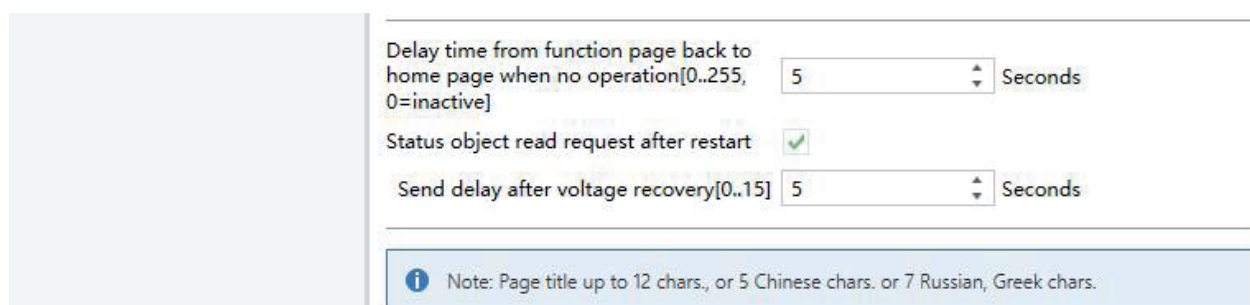

Fig. 5.1.1(2) “General setting” parameter window

## Parameter setting description in the ETS

### Parameter “Display mode”

This parameter is for setting the display mode of 01560, according to the installation direction of the device. Options:

- Vertical
- Horizontal

### Parameter “Interface Language”

This parameter is for setting the interface language of the touch panel, Options:

- |                      |         |
|----------------------|---------|
| Chinese(Simplified)  | Polish  |
| Chinese(Traditional) | Russian |
| English              | Turkish |
| German               | Italian |
| French               | Greek   |
| Spanish              | Other   |
| Japanese             |         |

### Parameter “Language name”

This parameter is visible when interface language is selected “Other”, used for input language name. The device will search for the corresponding language in the library according to the name and display it. When no corresponding language is searched, there will be displayed English by default.

**Note:** When select “Other” language, it is necessary to confirm with the manufacturer whether the language and the corresponding name is supported.

**Note:** The codepage option in the property of project must select the Unicode(UTF-8)

UTF-8 setting as shown as follow:

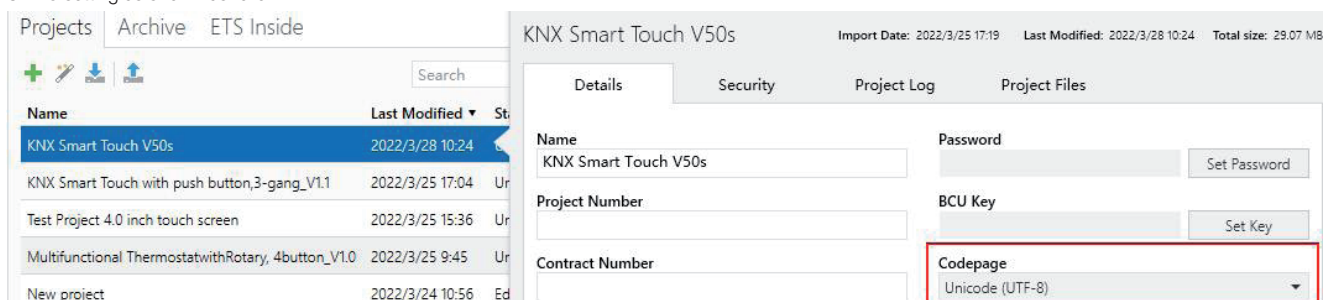

### Parameter “Send cycle of “In operation” telegram [1...240, 0 = inactive]s”

This parameter is for setting the time interval when cyclically send telegrams through the bus to indicate this device in normal operation. When set to “0”, the object “In operation” will not send a telegram. If the setting is not “0”, the object “In operation” will send a telegram according to the setting period time with logic “1” to the bus. Options:

- 0...240s, 0 = inactive

As to reduce the bus load as much as possible, the maximum time interval should be selected according to actual application requirement.

### Parameter “Temperature display units”

This parameter is for setting temperature display units. Options:

- Celsius (°C)
- Fahrenheit (°F)

### Parameter “Screen brightness can be changed via bus”

This parameter is for setting whether to adjust screen brightness via bus. If enabled, object “Screen backlight brightness” is visible which is used to change screen brightness.

## Parameter setting description in the ETS

### Parameter "Temperature display units"

This parameter is for setting whether the display of date/time on the interface can be modified by the bus.

If enabled, the object "Date" and the object "Time" are visible, date and time can be modified through the two objects respectively.

**Note:** The accuracy of RTC real-time clock inside the equipment is  $\pm 10$ ppm.

### Parameter "Date display format"

This parameter is for setting date display style of screen. Options:

**MM:** month; **dd:** day.

### Parameter "Send day/night status"

This parameter is for the definition of the day/night status. When status changes, status telegram will be sent through object "Day/Night". Options:

**No**

**Depend to certain time**

**Depend to sunrise&sunset**

No: do not send and objects is invisible.

Depend to certain time: switch the day/night status based on the specific time. Such as switch 18:30P.M. to the night status, 6:30A.M. to the day status.

Depend to sunrise&sunset: switch the day/night status based on the sunrise and sunset. The coordinate position of the reference point of sunrise and sunset, such as Beijing, China, needs to be defined, with the center located at east longitude 160°20' and north latitude 39°56'.

When "Depend to certain time" is selected, the following 4 parameters are visible, for setting the time to switch to the night or to the day.

- Parameter "Time for switch to night at: Hours [0..23]"
- Parameter "Time for switch to night at: Minutes [0..59]"

These two parameters are for setting the time point to switch to the night status, accurate to minutes, such as 18h: 0min.

- Parameter "Time for switch to day at: Hours [0..23]"
- Parameter "Time for switch to night at: Minutes [0..59]"

These two parameters are for setting the time point to switch to the day status, accurate to minutes, such as 18h: 0min.

When "Depend to sunrise&sunset" is selected, the following parameters are visible, for setting the time to switch to the night or to the day according to sunrise/sunset.

#### Time calibration

- Parameter "Switching time move to night [-128..127] min"

This parameter is for setting the delay time to switch to the night status after arrival to the time of sunset. Options:

-128..127

For example, if setting -10min, it will switch to night status 10min earlier before the sunset; if setting 10min, it will switch to night status 10min later after the sunset.

- Parameter "Switching time move to day [-128..127] min"

This parameter is for setting the delay time to switch to the day status after arrival to the time of sunrise. Options:

-128..127

For example, if setting -10min, it will switch to day status 10min earlier before the sunrise; if setting 10min, it will switch to day status 10min later after the sunrise.

**Note:** if summer time is set, then sunrise and sunset time will automatically adjust according to time interval of summer time. Details refer to section 5.1.4.

### Parameter "Colourful strip function"

This parameter is for setting whether to enable the indication function of colourful strip. If enabled, parameter setting interface as shown as Fig. 5.1.5.

### Parameter "Proximity sensor response function"

This parameter is for setting whether to enable proximity sensor response function. If enabled, parameter setting interface as shown as Fig. 5.1.6.

### Parameter "Password function"

This parameter is for setting whether to enable password function, that is, when entering screen saver or screen off, whether to input password when re-enter screen operation. If enabled, parameter setting interface as shown as Fig. 5.1.7, up to support 3 passwords.

## Parameter setting description in the ETS

### Parameter “Alarm function”

This parameter is for setting whether to enable alarm function. If enabled, parameter setting interface as shown as Fig. 5.1.8.

### Parameter “UI theme is”

This parameter is for setting the UI theme displayed in screen. Options:

**Dark style**

**Light style**

You can change the theme in **Setting | General para.** on the screen. The detail please refer to the UI description in the appendix.

### Parameter “UI style for Multifunction page”

Setting the UI style of the multifunction page (Multifunction(Lighting/Blind/Scene/Value send)). Options:

**Grid view**

**List view**

Display effect corresponding to the options please refer to the UI description in the appendix

#### • Parameter “Status indication”

This parameter is visible when option “Grid view” is selected in the previous parameter, for setting the indication effect of control status Options:

**Icon**

**Grid block**

Icon: indicating control status through the on/off status of the icons in the block. For example, the icon on indicates the lamp to turn on and the icon off indicates the lamp to turn off.

Grid block: indicating control status through the on/off status of the grid block. For example, the block on indicates the lamp to turn on and the block off indicates the lamp to turn off.

Specific effects please refer to the UI description in the appendix.

### Parameter “Screen saver”

Setting whether to enable screen saver. Options:

**Disable**

**Clock**

**Digital clock with air quality**

**Album (3 pictures)**

**Album (1 picture)**

Disable: the screen saver function is disabled.

Clock: screen will display clock when the panel enters to screen saver mode.

Digital clock with air quality: screen will display digital clock with air quality when the panel enters to screen saver mode.

Album(3 pictures /1 picture): screen will display 1 picture or 3 pictures of the program. When 3 pictures, switching in every 5s; when 1 picture, fix one to displayed.

**Tip: When album is selected, screen-saver picture of the program can be replaced through TF card. Details refer to the appendix.**

### Parameter “Delay time for screen saver [5..255]s”

This parameter is for setting the delay time to enter the screen saver, start counting from the last operation of screen.

**Options: 5..255**

### Parameter “Delay time for turn off backlight [0..255]s”

This parameter is for setting the delay time to turn off screen backlight, start counting when enter screen saver. If screen saver is disable, it will starting counting from the last operation of the screen.

When “Album (3 pictures)” or “Clock” is selected, options: **0..255**

When “Disable”, “Album(1 pictures)” or “Digital clock with air quality” is selected, options: **5..255**

When set to 0, screen keeps on, but you can turn on/off screen display via the object “Screen backlight on/off”, and the following note is displayed:

 **Note: It is only recommend that this option is used for demonstration purpose, screen may be damaged when it is on continuously for long time**

Parameter setting description in the ETS

**Parameter “Delay time from function page back to home page when no operation [0..255,0=inactive] s”**

This parameter is for setting the delay time from function page back to home page when no operation on the device. Options: 0...255

When setting to 0, it will not return to the home page automatically.

**Parameter “Status object read request after restart”**

Setting whether to send status read request telegram when the device starts up.

This parameter is suitable for the switch status feedback, dimming status feedback, curtain position feedback, air quality display, external temperature detection and energy metering display, etc.

After being enabled, when the device is started up or powered on again, it will send telegram to the bus to read the switch status or dimming brightness value.

After being enabled, when the device is started up or powered on again, it will send telegram to the bus to read curtain position status.

After being enabled, when the device is started up or powered on again, it will send telegram to the bus to read the value of temperature, humidity, CO2, PM2.5 etc. detected by the sensor.

After being enabled, when the device is started up or powered on again, it will send telegram to the bus to read the value of current, voltage, power, energy, etc. detected by the operator.

**• Parameter “Send delay after voltage recovery [0..15]s”**

This parameter is visible when the previous parameter is enabled. Setting the delay time to send status read request telegram after voltage recovery. Options: 0...15

The delay time is not considered for downloading, send read request telegram when initialization completed (if enabled to send).

When during the delay time, send function control telegrams immediately if the screen is operated, and cancel the corresponding status request telegrams. If received the bus data during the delay time, also cancel the corresponding status request telegrams.

Start the delay time when voltage recovery, send buffer data for status requests when arrival to the delay time. Under normal operation, if only the bus is power down, send status request telegrams immediately when bus recovery (Since the KNX bus and the device operating power supply belong to different power supplies).

**i** Note: Page title up to 12 chars., or 5 Chinese chars. or 7 Russian, Greek chars.

5.1.2 Parameter window “Coordinates location setting”

This parameter window for setting the coordinate position of the reference point of sunrise and sunset

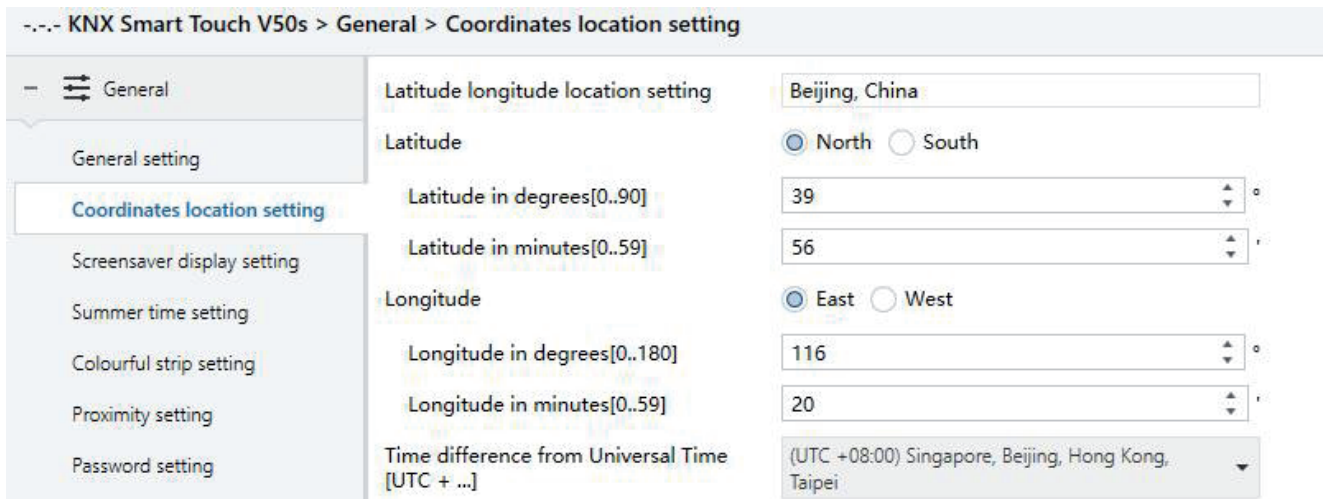

Fig. 5.1.2 “Coordinates location setting” parameter window

**Parameter “Latitude longitude location setting”**

Setting the reference point of sunrise and sunset, such as “Milan, Italy”.



## Parameter setting description in the ETS

### Parameter “Latitude”

Setting whether the reference point of sunrise and sunset is located at south latitude or north latitude. Options:

- South
- North

- Parameter “Latitude in degrees [0°..90°]”
- Parameter “Latitude in minutes [0'..59']”

These two parameters are for setting latitude.

### Parameter “Longitude”

Setting whether the base point of sunrise and sunset is located at east longitude or west longitude. Options:

- East
- West

- Parameter “Longitude in degrees [0°..180°]”
- Parameter “Longitude in minutes [0'..59']”

These two parameters are for setting longitude.

### Parameter “Time difference from Universal Time [UTC+...]”

This parameter is for setting the time difference from Universal Time. Options:

- (UTC -12: 00) International Date Line West
- (UTC -11: 00) Samoa
- ...
- (UTC +11: 00) Magadan, Salomon Islands, New Caledonia
- (UTC +12: 00) Auckland, Wellington, Fiji

### 5.1.3 Parameter window “Screensaver display setting”

This parameter window is visible when screen saver is selected “Digital clock with air quality”, for setting the screen saver display.

The screenshot shows the 'Screensaver display setting' window in ETS. The left sidebar contains a menu with options: General, General setting, Coordinates location setting, Screensaver display setting (highlighted), Summer time setting, Colourful strip setting, Proximity setting, Password setting, Alarm setting, and Advanced setting. Below the menu are icons for Home page, Function page, and Internal temperature measurement. The main area is titled '--- KNX Smart Touch V50s > General > Screensaver display setting'. It contains several settings:

- Items 1 display function: Int. temperature
- Items 2 display function: Ext. temperature
- Items 3 display function: Humidity
- Items 4 display function: PM2.5
- Time period for request external sensor [5..255]: 10 Minutes
- Object datatype of PM2.5:  Value in ug/m3(DPT\_7.001),  Float value in ug/m3(DPT\_9.030)
- Object datatype of PM10:  Value in ug/m3(DPT\_7.001),  Float value in ug/m3(DPT\_9.030)
- Object datatype of CO2:  Value in ppm(DPT\_7.001),  Float value in ppm(DPT\_9.008)
- Object datatype of VOC: Value in ug/m3(DPT\_7.001)
- Object datatype of Brightness:  Value in lux(DPT\_7.013),  Float value in lux (DPT\_9.004)
- Object datatype of Windspeed:  Float value in m/s(DPT\_9.005),  Float value in km/h(DPT\_9.028)

Fig. 5.1.3 “Coordinates location setting” parameter window



## Parameter setting description in the ETS

### Parameter "Items x display function" (x=1~4)

This parameter is for setting the air quality information displayed in screen saver, up to 4 items. Options:

None	CO2
Int. Temperature	VOC
Ext. Temperature	Brightness
Humidity	Wind speed
PM2.5	
PM10	

### Parameter "Time period for request external sensor [5..255] min"

This parameter is for setting the time period to read external sensor, send read requests by default after bus recovery or finish programming. Options:

5..255

### Parameter "Object datatype of display PM2.5/PM10"

This parameter is for setting the object datatype of display PM2.5/PM10. Options:

Value in  $\mu\text{g}/\text{m}^3$  (DPT\_7.001)  
Float value in  $\mu\text{g}/\text{m}^3$  (DPT\_9.030)

### Parameter "Object datatype of display CO2"

This parameter is for setting the object datatype of display CO2. Options:

Value in ppm (DPT\_7.001)  
Float value in ppm (DPT\_9.008)

### Parameter "Object datatype of display VOC"

This parameter is for setting the object datatype of display VOC. Options:

Value in  $\mu\text{g}/\text{m}^3$  (DPT\_7.001)  
Float value in  $\mu\text{g}/\text{m}^3$  (DPT\_9.030)  
Float value in ppm (DPT\_9.008)

### Parameter "Object datatype of display brightness"

This parameter is for setting the object datatype of display brightness. Options:

Brightness in lux (DPT\_7.013)  
Float value in lux (DPT\_9.004)

### Parameter "Object datatype of display wind speed"

This parameter is for setting the object datatype of display wind speed. Options:

Value in m/s (DPT\_9.005)  
Float value in km/h (DPT\_9.028)

## Parameter setting description in the ETS

### 5.1.4 Parameter window “Summer time setting”

Parameter window “Summer time setting” as shown as Fig. 5.1.4, it is mainly for setting summer time adjustment and start/end time.

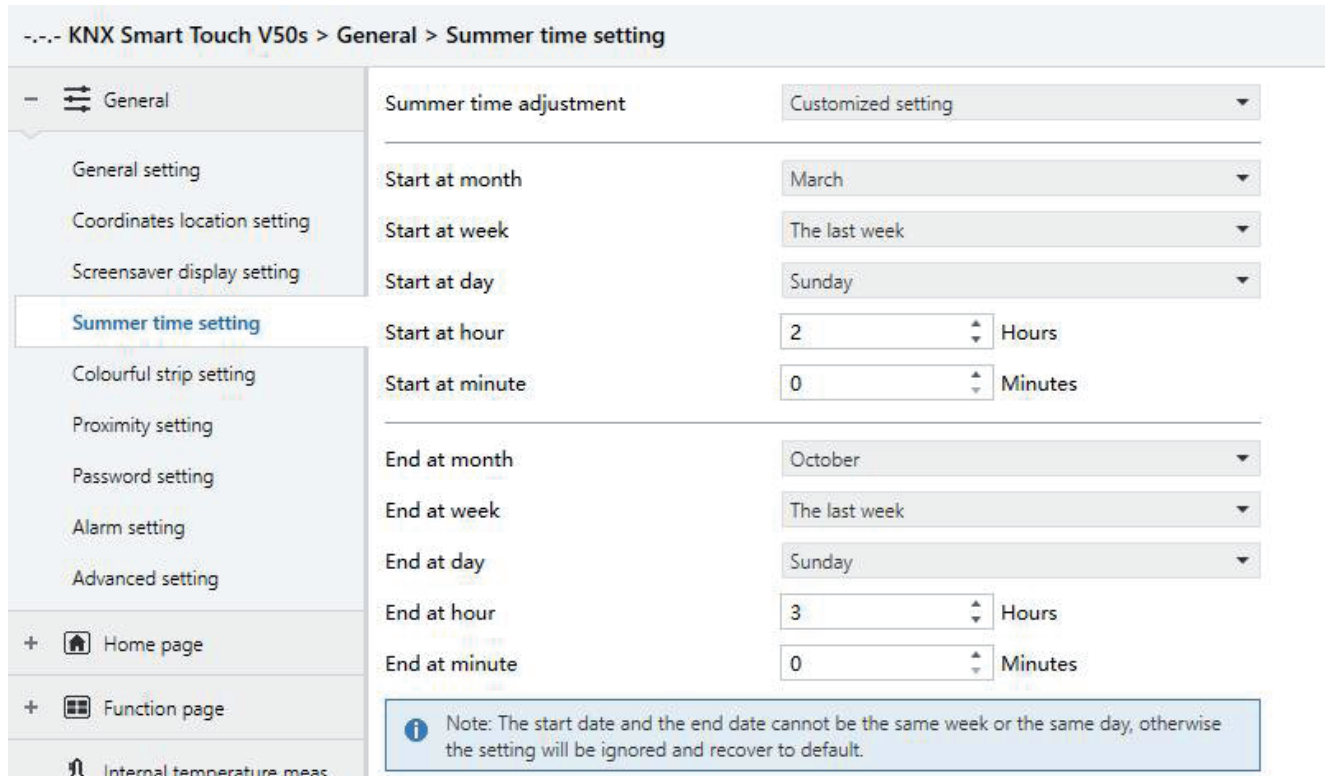

Fig. 5.1.4 “Summer time setting” Parameter window

#### Parameter “Summer time adjustment”

This parameter is for setting the summer time. Options:

- No
- Always
- Customized setting

No: disable summer time.

Always: always enable summer time.

Customized setting: for customized setting the start/end time of summer time.

*When select “Customized setting”, the following parameters are visible, for setting the start and end time of summer time.*

- **Parameter “Start/End at month”**

This parameter is for setting summer time start or end at month. Options:

- January
- February
- ...
- December

- **Parameter “Start/End at week”**

This parameter is for setting summer time start or end at week. Options:

- The first week
- The second week
- ...
- The last week

- **Parameter “Start/End at day”**

This parameter is for setting summer time start or end at day. Options:

- Monday
- Tuesday
- ...
- Sunday

## Parameter setting description in the ETS

- Parameter “Start/End at hour [0..23]”
- Parameter “Start/End at minute [0..59]”

These parameter are for setting summer time start or end time, accurate to minutes, such as 18h: 00min.

Take American time for example, setting summer time start from 02h: 00min, the second Sunday of March to 02h: 00min, the first Sunday of November each year, so during this summer time, when it comes to the start time, system default time will be an hour faster, displayed time on the device will be 03h: 00min; when it comes to the end time, system default time will be an hour slower, displayed time on the device will be 02h:00min.

**Note:** The start date and the end date cannot be the same week or the same day, otherwise the setting will be ignored and recover to default.

The start date and the end date cannot be the same. That is, if you set the same month, week, and day, it will be ignored and recovered to default. If only the month and week are set to the same will also be ignored.

### 5.1.5 Parameter window “Colourful strip setting”

Parameter window “Colourful strip setting” as shown as Fig. 5.1.5, it is mainly for setting the brightness of colourful strip and colour indication.

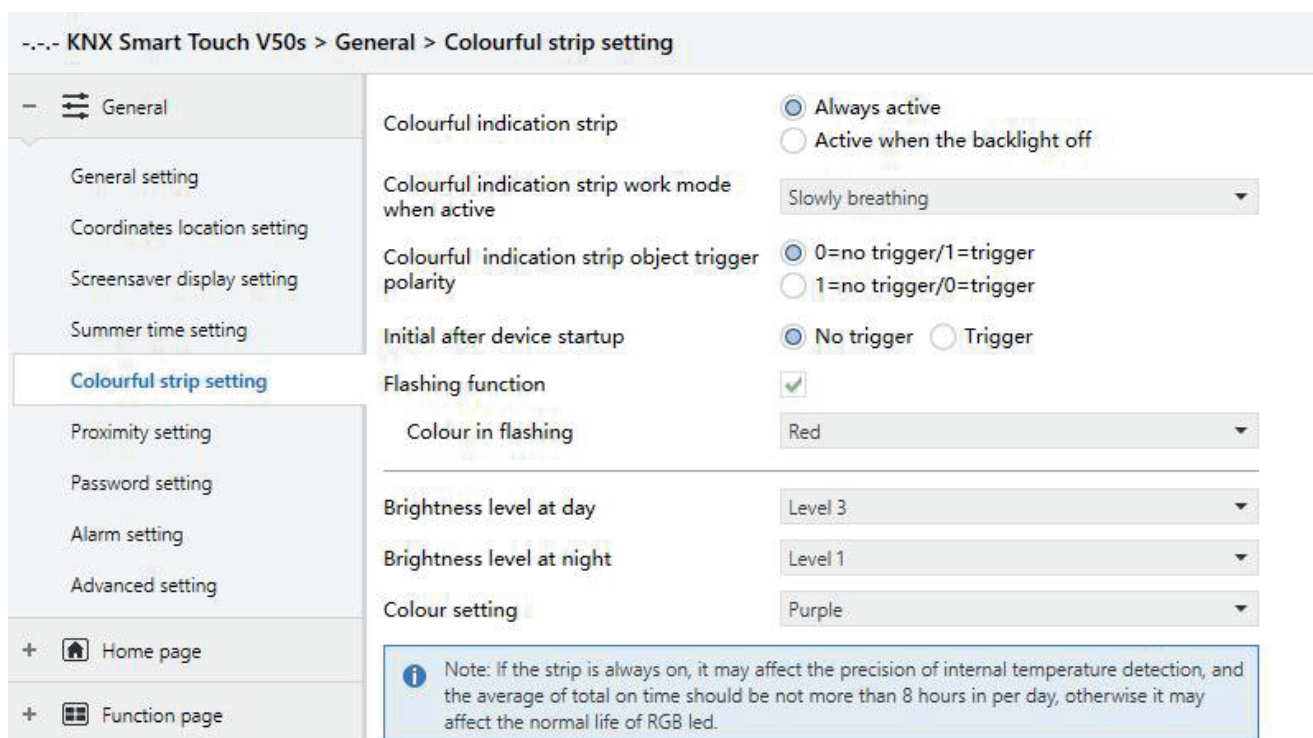

Fig. 5.1.5 “Colourful strip setting” parameter window

#### Parameter “Colourful indication strip”

This parameter is for setting the colourful strip control type. Options:

- Always active**
- Active when the backlight is off**

Always active: there is always indication of colourful strip.

Active when the backlight is off: colourful strip only shows the indication effect after the screen is off. When the screen is on, colourful strip exits the indication status.

#### Parameter “Colourful indication strip work mode when active”

This parameter is for setting the work mode when the colourful strip indicates. Options:

- Permanent on**
- Slowly breathing**
- White dynamic display**
- Colour range cycle**

## Parameter setting description in the ETS

Permanent on: the strip indication is permanent on.

Slowly breathing: the strip is 5 seconds on, 25 seconds off, to prevent the service life from being shortened due to the long-time lighting of the LED.

White dynamic display: the strip is white dynamic display, that is the inside of the strip displays white in turn from left to right, while the other LEDs display normally according to the configured colour and brightness level.

Colour range cycle: the strip displays cyclically according to the order of red/green/blue /white/yellow/cyan/purple/orange/cyan blue.

- **Parameter “Interval time of dynamic display [1..5]s”**

This parameter is visible when previous parameter is selected “White dynamic display”, setting the interval time for displaying white in turn. Options:

1...5

- **Parameter “Interval time of colour shift [3..255]s”**

This parameter is visible when previous parameter is selected “Colour range cycle”, setting the interval time for display various colours, that is interval time of the colour switching to another colour. Options

1...255

### Parameter “Colourful indication strip object trigger polarity”

This parameter is for setting the trigger value of the communication object indicated by colourful strip. Options:

**0=no trigger/1=trigger**

**1=no trigger/0= trigger**

0=no trigger/1=trigger: when the object “Colourful strip trigger” receives the telegram “1”, it will trigger colourful strip indication. When telegram “0” is received, colourful strip has no indication. Vice versa.

### Parameter “Initial after device startup”

This parameter is for setting the initial trigger status when the device is on. Options:

**No trigger**

**Trigger**

No trigger: colourful strip is not triggered and there is no indication.

Trigger: after the device is started, colourful strip is triggered and can be indicated.

### Parameter “Flashing function”

This parameter is for setting whether to enable flashing function of colourful strip.

The flashing function is usually used as an alarm indication that takes precedence over normal indications, that is, if the function is triggered, the strip will be flashing and recovered to normal indications after the flashing stop. The frequency of the strip flashing is 2.5 seconds on and 2.5 seconds off, and the colour is configured in the next parameter.

- **Parameter “Colour in flashing”**

This parameter is for setting the colour when the strip is flashing. Options:

**Red**

**Cyan**

**Green**

**Purple**

**Blue**

**Orange**

**White**

**Cyan blue**

**Yellow**

### Parameter “Brightness level at day”

This parameter is for setting the brightness level of colour strip at day. Options:

**Level 1**

**Level 2**

**Level 3**

**Level 4**

**Level 5**

Level 1 is the darkest and Level 5 is the brightest

## Parameter setting description in the ETS

### Parameter "Brightness level at night"

This parameter is for setting the brightness level of colour strip at night. Options:

- OFF
- Level 1
- Level 2
- Level 3
- Level 4
- Level 5

OFF is off, Level 1 is the darkest and Level 5 is the brightest

### Parameter "Colour setting"

This parameter is for setting the indication colour of the strip. Options:

- |        |                                  |
|--------|----------------------------------|
| Red    | Purple                           |
| Green  | Orange                           |
| Blue   | Cyan blue                        |
| White  | Automatically adjust via seasons |
| Yellow | Receive a 3byte value            |
| Cyan   |                                  |

When the work mode of the colourful strip indication is selected "Colour range cycle", this parameter is not visible.

When it is selected "White dynamic display", no the options **White "Automatically adjust via seasons"**

#### Receive a 3byte value

When it is selected "Automatically adjust via seasons", parameters as follow are visible, for setting the starting and ending of the seasons, and specify the colour of the strip in each season.

### Parameter "Colour on Spring/Summer/Autumn/Winter"

This parameter specifies the strip indication colours in each season: Spring-yellow, Summer-white, Autumn-green, Winter-orange.

- **Parameter "Spring/Summer/Autumn/Winter time start at: Month/Day"**

Setting the starting month and day of each season, as well as the end month and day.

**i** Note: If the strip is always on, it may affect the precision of internal temperature detection, and the average of total on time should be not more than 8 hours in per day, otherwise it may affect the normal life of RGB led.

## Parameter setting description in the ETS

### 5.1.6 Parameter window “Proximity setting”

Parameter window “Proximity setting” as shown as Fig. 5.1.6. It is mainly setting proximity function, which can set the telegram when proximity approaching and leaving, and the delay time for sending telegram.

*Note: if no proximity approaching is detected when there is touch operation, it will be dealt with proximity approaching.*

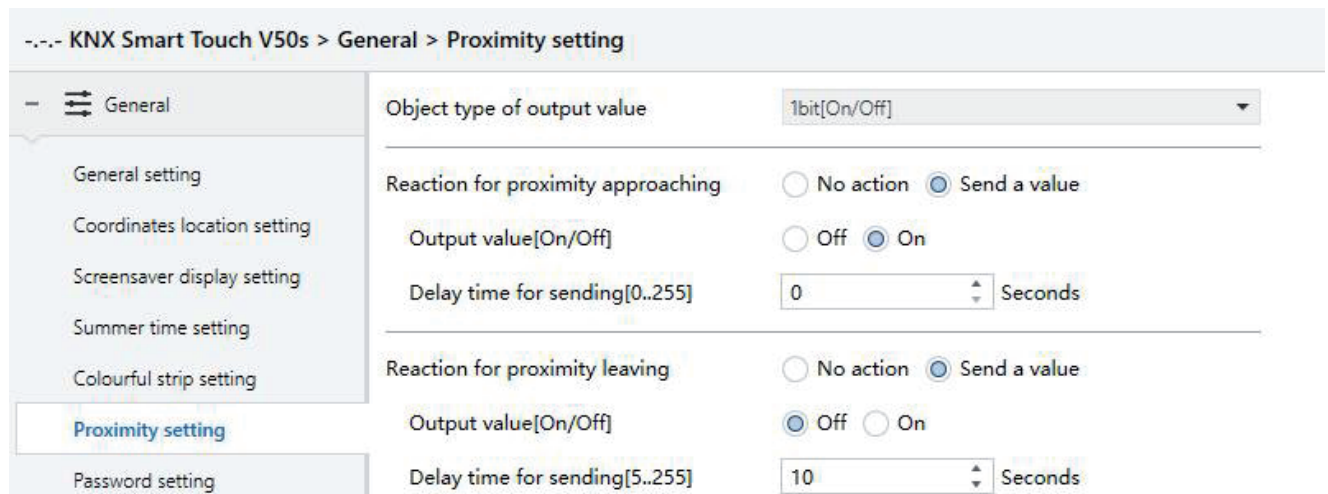

Fig. 5.1.6 “Proximity setting” parameter window

#### Parameter “Object type of output value”

This parameter is for setting the object type of output value to the bus when proximity approaching or leaving. Options:

- 1bit [On/Off]
- 1byte [scene control]
- 1byte [0..255]
- 1byte [0..100%]

#### Parameter “Reaction for approaching/leaving”

This parameter is for setting whether to send telegram when proximity approaching or leaving. Options:

- No send
- Send a value

Send a value: the following parameters are visible.

- Parameter “Output value [On/Off]”
- Parameter “Output scene NO.[1..64]”
- Parameter “Output value [0..255]”
- Parameter “Output value [0..100%]”

These parameters are for setting the output value sending to the bus when proximity approaching or leaving, the range of value is determined by the data type.

- Parameter “Delay time for sending [0..255]”

This parameter is for setting the delay time for sending telegram. Options:

- 0..255

*Note: If telegram of proximity leaving need to be sent during the delay time of proximity approaching, then ignore the telegram of proximity approaching, telegram send once when status of proximity approaching has changed.*

## Parameter setting description in the ETS

### 5.1.7 Parameter window “Password setting”

Parameter window “Password setting” as shown as Fig. 5.1.7, it is mainly setting password function and the object type of output value sent to the bus after device is activated through password, up to set three passwords, and password 1 can also be set to access the setting page.

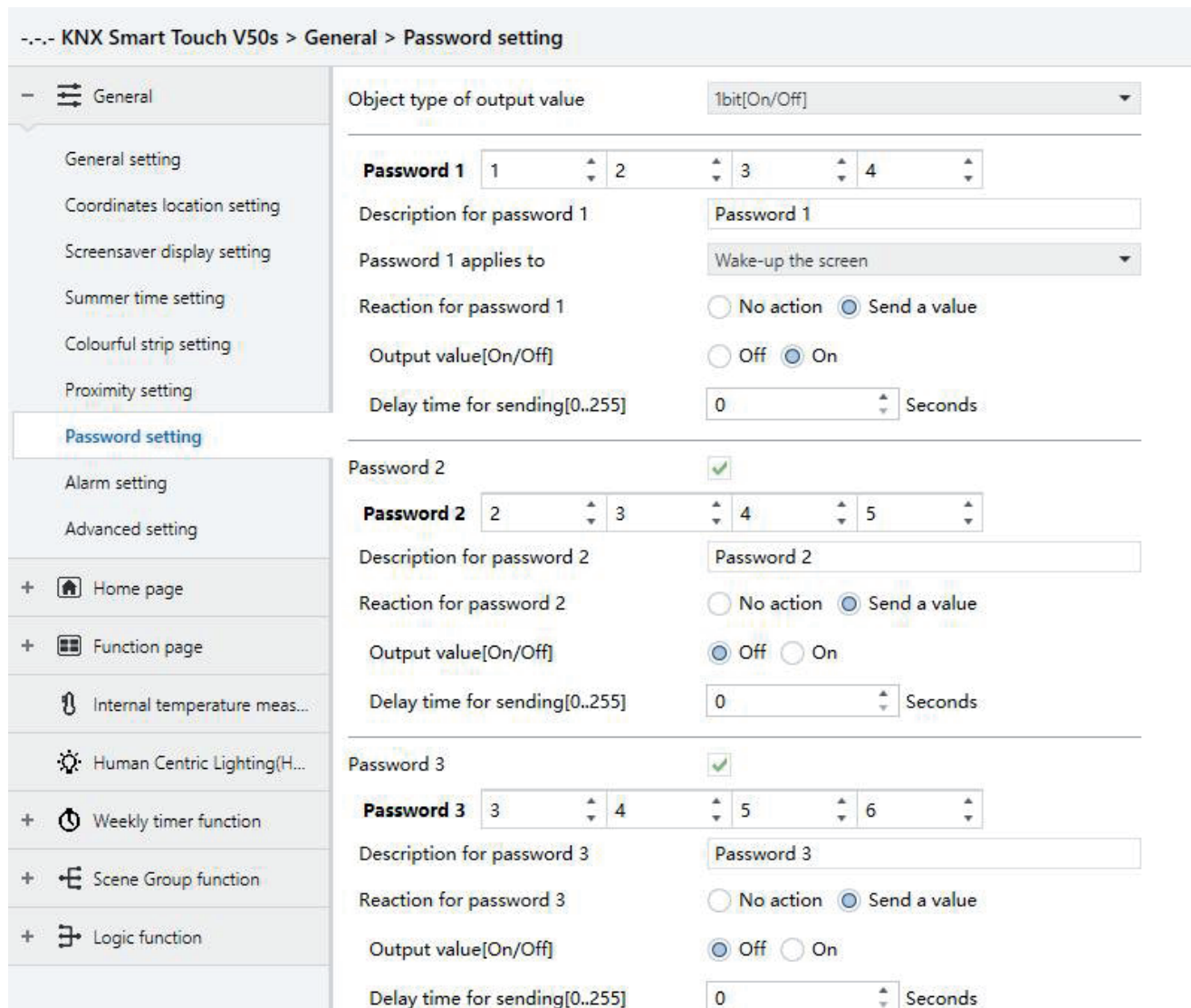

Fig. 5.1.7 “Password setting” parameter window

#### Parameter “Object type of output value”

This parameter is for setting the object type of output value sent to the bus after the device activated through password. Options:

- 1bit[On/Off]
- 1byte[scene control]
- 1byte[0..255]
- 1byte[0..100%]



## Parameter setting description in the ETS

### Parameter “Password 1”

This parameter is for setting whether to enable password 1, only 4 bytes digit number is allowed.

- **Parameter “Description for password 1”**

This parameter is for setting the description for password 1, only 40 bytes characters are allowed.

- **Parameter “Password 1 applies to”**

This parameter is for setting the password 1 applies to access setting page or wake-up the screen, or both. Options:

Access setting page

Wake-up the screen

Both access setting page and wake-up the screen

*Parameters as follow are visible when “Wake-up the screen” is selected, for setting to send telegrams.*

*It cannot send the telegrams to bus when access setting page.*

### Parameter “Reaction for password 1”

This parameter is for setting whether to enable the trigger reaction for password 1. Options:

No action

Send a value

Send a value: when select this option, the following parameters are visible.

- **Parameter “Output value [On/Off]”**

- **Parameter “Output scene NO. [1..64]”**

- **Parameter “Output value [0..255]”**

- **Parameter “Output value [0..100%]”**

These parameter are for setting the output value sent to the bus when password triggered, the range of output value is determined by the selected data type.

- **Parameter “Delay time for sending [0..255]s”**

This parameter is for setting the delay time for sending. Options:

0..255

### Parameter “Password 2”

This parameter is for setting whether to enable password 2. The parameter of password 3 can only be set after password 2 is enabled.

### Parameter “Password 3”

This parameter is for setting whether to enable password 3.

The configuration of password 2 and password 3 are similar as password 1, hereinafter will no longer describe. The different is the password 2 and password 3 cannot be applied to access setting page, only used for wake-up screen.

**Note: up to 3 passwords can be set. If all passwords are set as the same, and send a value to the bus, then it will send the telegram of Password 1 to the bus when device is activated.**

#### 5.1.8 Parameter window “Alarm setting”

Parameter window “Alarm setting” as shown as Fig. 5.1.8, it is mainly setting alarm function.

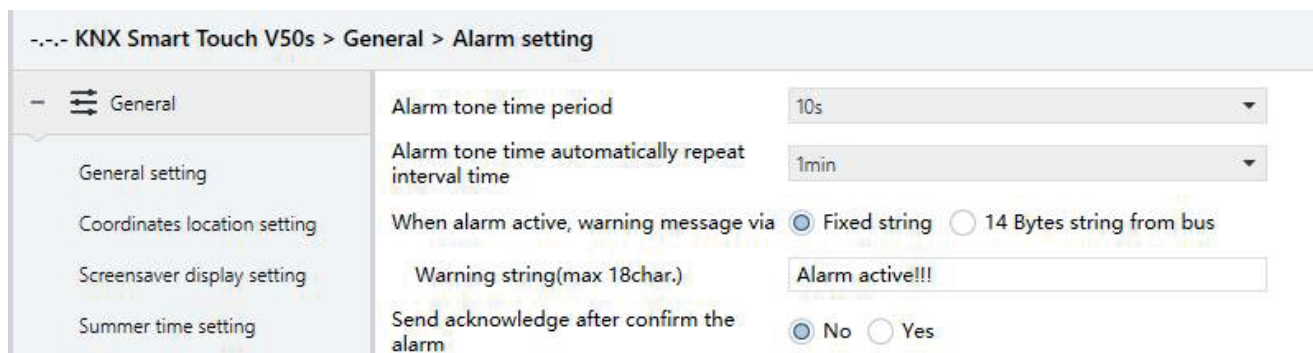

Fig. 5.1.8 “Alarm setting” parameter window



## Parameter setting description in the ETS

### Parameter “Alarm tone time period”

This parameter is for setting the time period of alarm tone. When receive the alarm telegram, play alarm tone immediately, if currently playing and it will not be interrupted and will not be re-timed. If receive the cancel alarm telegram when playing, it will be interrupted immediately. Options:

**Disable**

**10s**

**20s**

**...**

**25min**

**30min**

Disable: disable the alarm tone playing function;

Other options: the playing period of alarm tone.

### Parameter “Alarm tone time automatically repeat interval time”

This parameter is visible when previous parameter is enabled. Set the interval at which alarm tone time automatically repeat, and the timing is only related to when the last play ended. Options:

**Disable**

**10s**

**20s**

**...**

**25min**

**30min**

Disable: disable the alarm tone repeat function;

Other options: when a playing period complete, it will automatically play again after a delay of the setting time.

### Parameter “When alarm active, warning message via”

When alarm activated, this parameter is for setting input type of warning message, either by displaying a fixed string entered by ETS on the screen or by receiving a 14byte string from the bus. Options:

**Fixed string**

**14 Bytes string from bus**

When it is selected “14 Bytes string from bus”, display the information as follow:



**i** The encode data of telegram must be ISO8859 or ASCII characters

The encode data of alarm telegram is associated with interface language, when it is selected Simplified Chinese, Traditional Chinese, Russian or Greek, use UTF-8; while other languages, use ISO8859.

### Parameter “Warning string (max 18char.)”

This parameter is visible when previous parameter is selected “Fixed string”. Set the indicate text when alarm activated.

### Parameter “Send acknowledge after confirm the alarm”

This parameter is for setting whether to send a 1bit acknowledge telegram, the action that only needs to be processed when the user clicks on the screen to acknowledge the warning message.

## Parameter setting description in the ETS

### 5.1.9 Parameter window “Advanced setting”

Parameter window “Advanced setting” as shown as Fig. 5.1.9, it is mainly setting to enable human centric lighting function, weekly timer function, scene Group function and logic function.

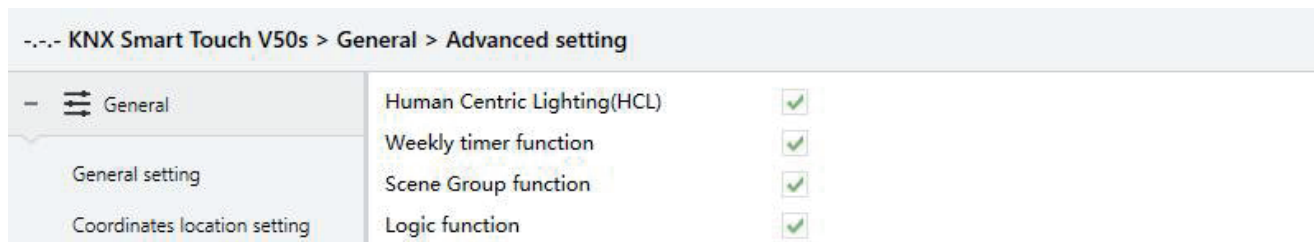

Fig. 5.1.9 “Advanced setting” parameter window

#### Parameter “Human Centric Lighting (HCL)”

Setting page of human centric lighting (HCL) function is visible after this parameter enabled.

#### Parameter “Weekly timer function”

Setting page of weekly timer function is visible after this parameter enabled.

#### Parameter “Scene Group function”

Setting page of scene group function is visible after this parameter enabled.

#### Parameter “Logic function”

Setting page of logic function is visible after this parameter enabled.

## 5.2 Parameter window “Home page”

### 5.2.1 Parameter window “Home page setting”

Parameter window “Home page setting” as shown as Fig. 5.2.1, for setting to enabled home page function, up to 5 home pages can be set. If disabled the function, display function pages directly, select a specific function page by swiping the page when there are multiple pages.

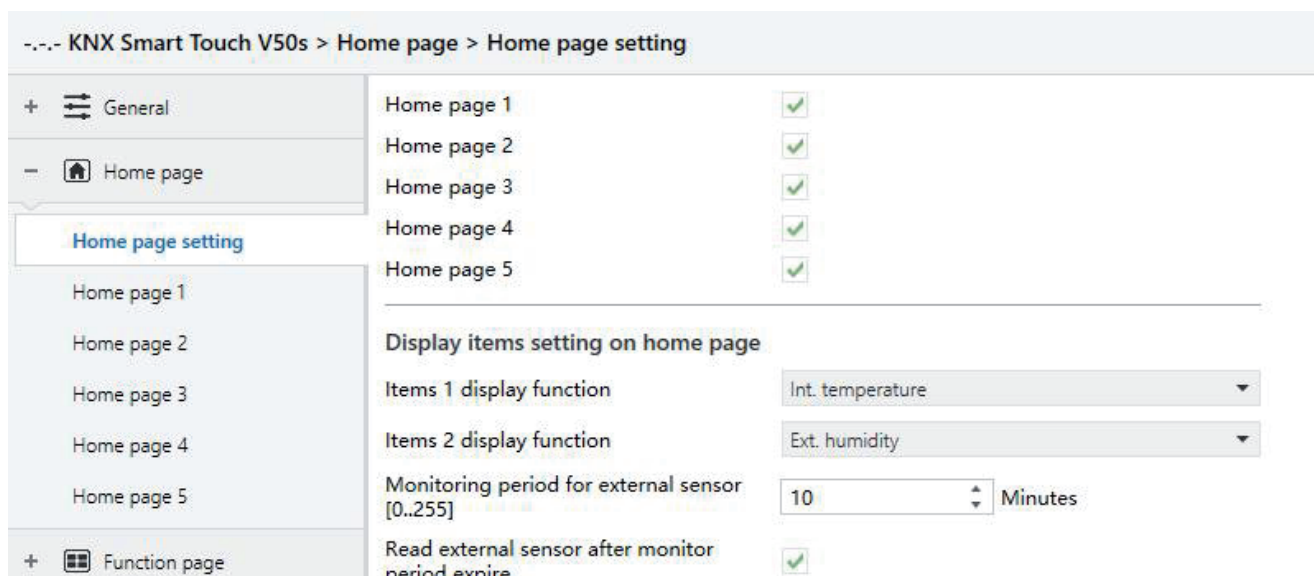

Fig. 5.2.1 “Home page setting” parameter window

## Parameter setting description in the ETS

### Parameter "Home page x" (x=1~5)

Home page x is visible after this parameter is enabled. Up to 5 home pages can be set.

**Note: it is up to set 3 home pages for V40s.**

#### Display items setting on home page

The following is to set the temperature and humidity display for the home page, up to 2 items can be set, the first is temperature and the second is humidity or temperature

### Parameter "Items 1 display function"

Items 1 display setting, to set the reference source for temperature value displayed on the screen home page. Options:

Disable

Int. temperature

Ext. temperature

Int. temperature: the temperature value measured by internal sensor, and it is sent or read to the bus by the object "Actual temperature";

Ext. temperature: to measure the temperature value through other temperature control devices on the bus and receive the value from the object "External temperature value"; When the device does not receive the measured value from external sensor, the temperature will be not displayed or displayed the value measured by the internal sensor.

### Parameter "Items 2 display function"

Items 2 display setting, to set the external temperature or humidity value displayed on the screen home page. Options:

Disable

Ext. temperature

Ext. humidity

The items 2 only can be set to external humidity or disable when the items 1 is set as external temperature.

### Parameter "When Ext. temperature sensor fault occurs, Internal sensor display"

This parameter is visible when the external temperature sensor is selected. For setting whether to enable internal sensor measurement when external sensor fault occurs.

Refer to the following when the sensor fault occurs:

If disabled, no temperature value is displayed when external sensor fault occurs; while when the fault occurs after a period of normal use, previous received measurement is displayed.

If enabled, internal sensor measurement is displayed when external sensor fault occurs. **Note: If internal sensor also fails at this time, "-20°C" or "-68°F" is displayed on the screen.**

The following two parameters are for setting the monitoring period for external temperature and humidity sensor. Only suitable for temperature and humidity display of home page on the device:

### Parameter "Monitoring period for external sensor [0..255] min"

This parameter is for setting the period of device monitoring external sensor. Monitoring period will restart counting when the device receives value. Options:

0..255

When the monitoring period arrives, if the detection value of the external sensor is not received, it will be considered as external sensor fault, or through parameter "When Ext. temperature sensor fault occurs, Internal sensor display" to enable the display of the value measured by the internal sensor.

**Note: to prevent missing detection values from bus busy, it is recommended that monitoring period should be at least twice longer the sensor's cyclic transmission period.**

## Parameter setting description in the ETS

### Parameter “Read external sensor after monitor period expire”

Setting whether to send read request telegram to external sensors after the monitoring period expires.

When disabled, do not send read request telegram.

When enabled, after the monitoring period expires, if the screen does not receive the detection value of the external sensor, a read request telegram will be sent to the external sensor.

**Note:** due to the large heating of LCD screen, if internal sensor is used to detect temperature, the setting time for turning off backlight is recommended to be 5 ~ 15s.

### 5.2.2 Parameter window “Home page x”

Parameter window “Home page x” as shown as Fig. 5.2.2, for setting the layout and page navigation function of the home page, up to 5 home pages can be set, and up to 8 pages or icons navigation in the Multifunction page can be set. The parameters for each navigation are the same, and can be linked to the specified function page. The following is an example of a navigation function that describes their parameter settings.

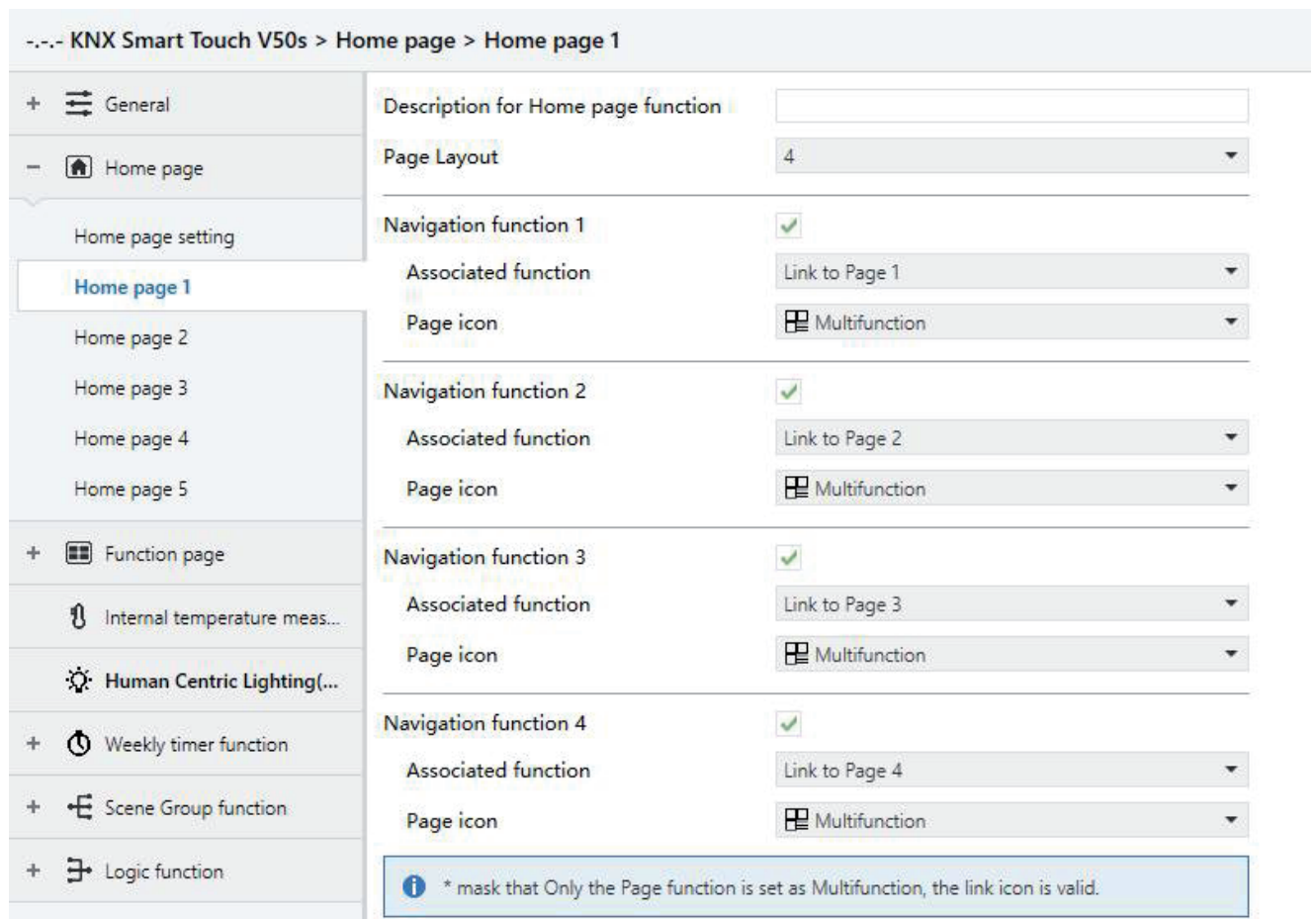

Fig. 5.2.2 “Home page x” parameter window

### Parameter “Description for Home page function”

Setting the interface name of the home page, maximum 15 characters, the actual maximum display character is up to 5 Chinese characters.

## Parameter setting description in the ETS

### Parameter "Page Layout"

Setting the page layout of home page, that is, the displayed page number in homepage. Options: 3/4/6/8

Up to 8 navigation function page can be set to display in one homepage. Directly click one of the icons to quickly jump to the selected function control interface.

### Parameter "Navigation function x, x=1...9"

Setting whether to enable navigation function x. When enabled, the following parameters are visible.

- Parameter "Associated function"

Setting the function page or the icons of multifunction page that the navigation function x links to. Options:

Link to Page 1

...

Link to Page 15

Link to icon in Page 1 \*

...

Link to icon in Page 15 \*

The previous 15 options for linking to function page, the last 15 options for linking to one of the icons of the multifunction page.

**Note: It is up to set 9 function pages or the icons of multifunction pages for associated function of V40s.**

**Note: The linked function page needs to be configured. If it is not configured, the link is invalid.**

**Similarly, the linked multifunction page needs to be configured, and the icons of the page also need to be configured, otherwise they are not valid.**

- Parameter "Page icon"

This parameter is visible when the previous parameter linked to the function page, for setting the icons in the function page. Options:

Multifunction

Lighting

Scenario

...

Reception

Icons corresponding to each option are described in the appendix.

- Parameter "Icon number"

This parameter is visible when the parameter "Associated function" linked to the icon in multifunction page, for setting the linked icon number. Options:

1/2/3/4/5/6/7/8

**Note: it is up to set 6 icons in multifunction page for V40s.**

For example, "Link to icon in Page 2 \*" in parameter "Associated function" is selected, this icon number is set to be 5, that is, link to the 5th icon of the multifunction page 2.



\* mask that Only the Page function is set as Multifunction, the link icon is valid.

For example, "Link to icon in Page 6 \*" is selected from the parameter "Associated function", but if Page 6 is not set to Multifunction, then the link is not valid.

## Parameter setting description in the ETS

### 5.3 Parameter window “Function Page”

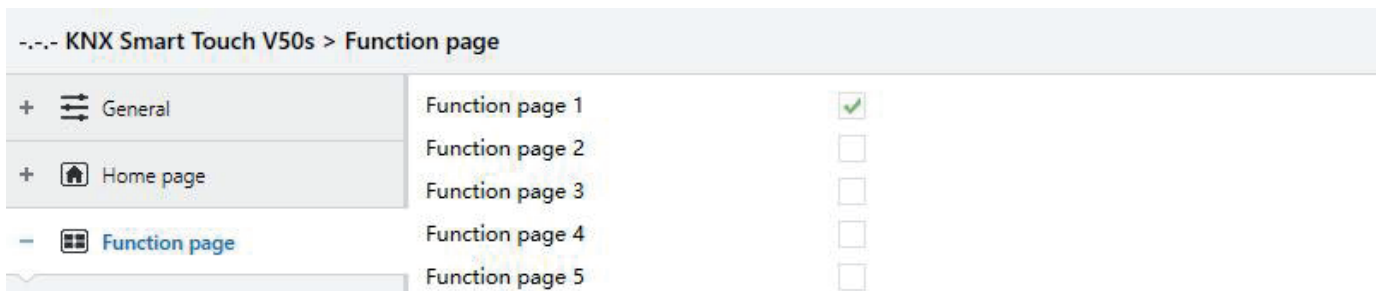

Fig. 5.3(1) “Function page” parameter window

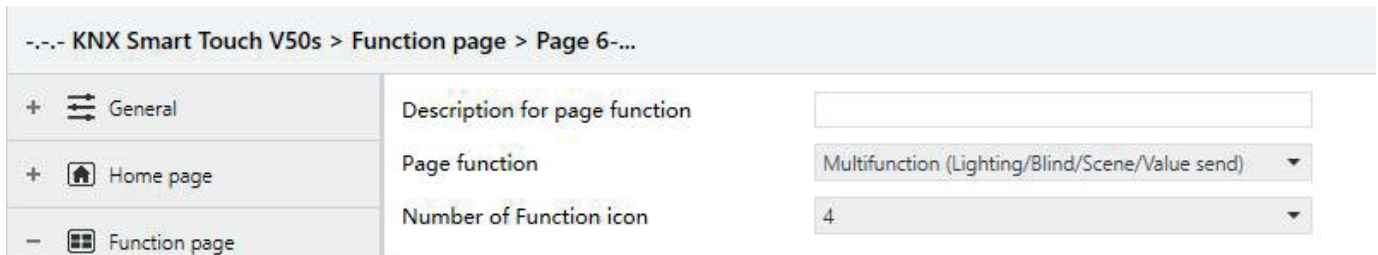

Fig. 5.3(1) “Function page” parameter window

#### Parameter “Function page x (x=1..15)”

This parameter is for setting whether to enable function page x. When enabled, parameter interface “Page x-...” is visible, as shown as Fig. 5.3.1(1), the function of page x can be set in this interface.

Up to 15 function pages can be set.

#### Parameter “Description for page function”

This parameter is for setting the title name of function page interface, up to 15 characters can be input.

#### Parameter “Page function”

This parameter is for setting the function of page. Options:

- Multifunction (Lighting/Blind/Scene/Value send)
- Room temperature control
- Air conditioner
- Audio control
- Colour and colour temperature control
- Air Quality display
- Floor heating
- Ventilation System
- Energy Metering display

*Note: the display of the interface depends on the function selected, page 1-5 only for multifunction setting, while page 6-15 for all the functions setting.*

The following sections describe the parameter settings for each function.

## Parameter setting description in the ETS

### 5.3.1 Parameter window “Multifunction”

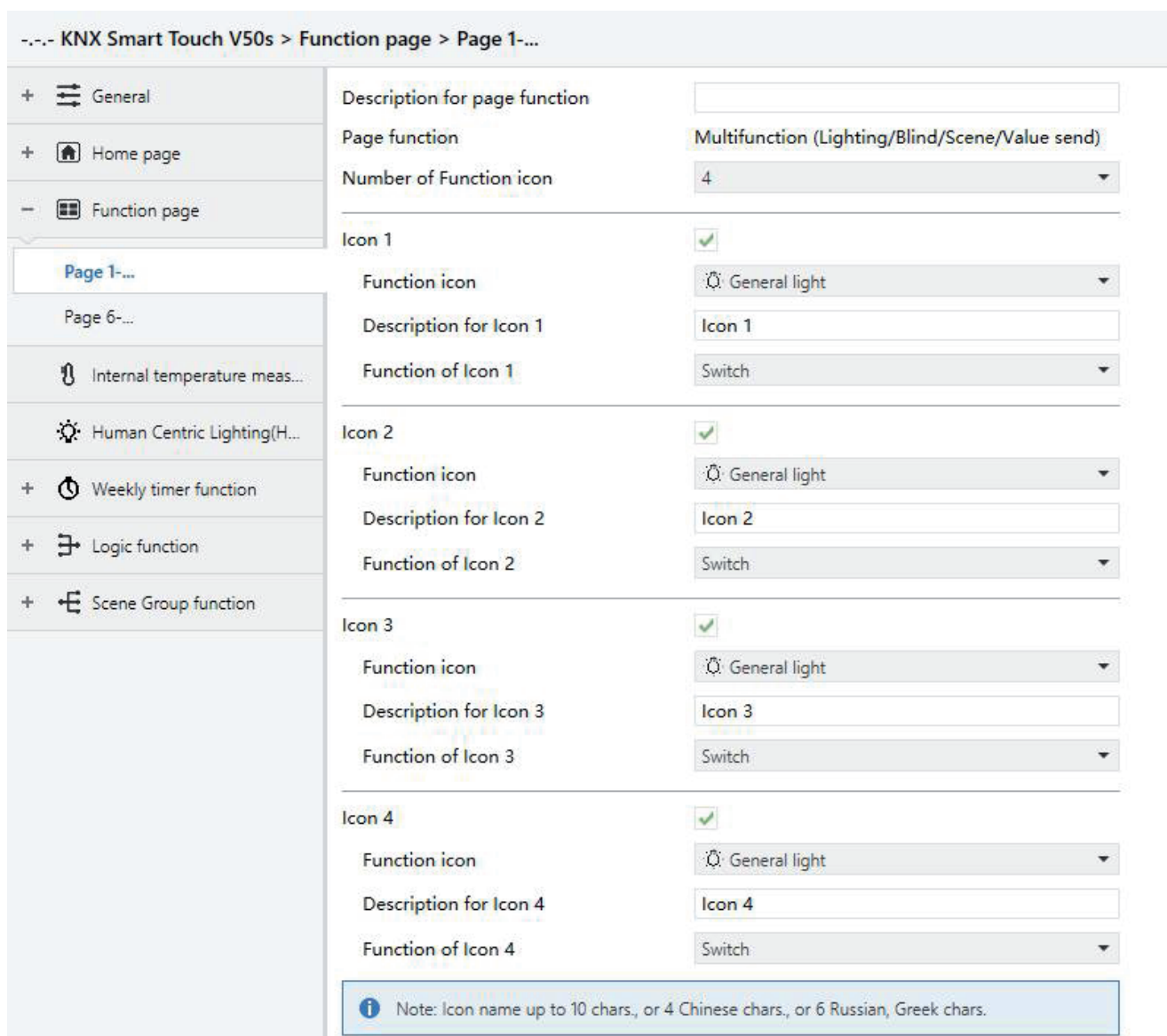

Fig. 5.3.1 “Multifunction (Lighting/Blind/Scene/Value send)” parameter window

In this section, the functions of page are mainly about settings for multifunction, such as lighting, curtains, scene and value sender, as follows:

#### Parameter “Number of Function icon”

This parameter is for setting the number of function icon in the multifunction page. Options:

3/4/6/8

#### Parameter “Icon x” (x=1~8)

This parameter is for setting whether to enable function of icon x. When enabled, the following parameters are visible.

## Parameter setting description in the ETS

### Parameter “Function icon”

This parameter is for setting the icon for using. Options :

**No icon, only text**

**General light**

...

**MUR**

Icons corresponding to each option are described in the appendix.

### Parameter “Description for Icon x”

This parameter is for setting the description displayed on the screen for Icon x, up to 12 characters can be input. The actual display is up to 9 characters ( or 4 Chinese characters).

### Parameter “Function of Icon x”

This parameter is for setting the function of Icon x. Options:

**Switch**

**Press/Release switch**

**Relative dimming**

**Brightness dimming**

**Relative+Brightness dimming**

**Brightness + Colour Temperature**

**Value sender**

**Curtain position**

**Roller Blind position**

**Venetian Blinds position and slat**

**Curtain step/move**

**Roller blind step/move**

**Scene control**

**Switch indicator**

**Switch:** the function of icon is for switch controlling. Object “Switch” and “Switch status” are visible, in general, the two objects are used in conjunction. For example, “Switch” corresponding to the switch object of the switch actuator, “Switch Status” corresponding to the switch status object, if the object “Switch Status” receives the status feedback of switch actuator, the icon status will also update as well.

**Press/Release switch:** the function of icon is for switch controlling. The object “Switch” is visible. Work for when press or release the switch.

**Relative dimming:** the function of icon is for switch and relative dimming. Object “Switch”, “Switch status” and “Relative dimming” are visible, short press operation will trigger a switch command. Long press operation to trigger a relative dimming command, press to reverse dimming, then release to stop dimming, only support start-stop dimming mode.

**Brightness dimming:** the function of icon is for switch and relative dimming. Object “Switch”, “Brightness value” and “Brightness, status” are visible, short press operation will trigger a switch command. Long press operation to enable a slider for dimming, which can be slid to dimming.

Generally, object “Brightness value” and “Brightness status” are used in conjunction. For instance, “Brightness value” corresponding to the brightness dimming object of the dimming actuator, “Brightness Status” corresponding to the brightness status object of the dimming actuator.

**Relative + Brightness dimming:** the function of icon is for relative and brightness dimming. Object “Switch”, “Switch, status”, “Brightness value”, “Brightness Status” and “Relative dimming” are visible, short press operation will trigger a switch command. Long press operation to enable a slider for dimming, which can be slid to dimming. Relative dimming via two button: dimming up, dimming down, long press then release to stop dimming.

**Brightness + Colour Temperature:** the function of icon is for brightness dimming and colour temperature control. Object “Switch” and “Switch, status” are visible, support to control the light switch and feedback the status.

The type of colour temperature control can be selected normal or directly control, its objects support to control colour temperature and brightness, and feedback the status. The maximum colour temperature range is 2000~7000K, and the maximum and minimum threshold ranges are supported to configure. **Note: when minimum value is greater than or equal to maximum value, range default to 2000~7000K.**

**Value sender:** the function of icon is for value sending, to specify sending different types of value.

**Curtain position:** the function of icon is for curtain controlling, supports to adjust the curtain position by sliding the slider in percentage, as well as controlling through the three buttons: opening, closing, stop moving.

**Roller blind position:** the function of icon is for roller blind controlling, supports to adjust the roller blind position by sliding the slider in percentage, as well as controlling through the three buttons: moving up, moving down, stop moving.



## Parameter setting description in the ETS

**Venetian blind position and slat:** the function of icon is for venetian blind controlling, supports to adjust the venetian blind position and slat by sliding the slider in percentage, as well as controlling through the three buttons: moving up, moving down, stop moving.

**Curtain step/move:** the function of icon is for curtain controlling, supports to control the curtain through the three buttons: opening, closing, stop moving.

**Roller blind step/move:** the function of icon is for roller blind controlling, supports to control the roller blind position through the three buttons: moving up, moving down, stop moving.

**Scene control:** for scene controlling, touch to recall scene, and long operation for scene storage.

**Switch indicator:** the function of icon is for switch indicator. Object "Switch, status" is visible, if the object receives the status feedback of switch actuator, the icon status will also update as well.

The following parameter is visible when "Press/Release switch" is selected:

- **Parameter "Work mode"**

This parameter is for setting the work mode for Press/Release switch. Options:

- Press - ON / Release - OFF
- Press - OFF / Release - ON

The following parameters are visible when "Brightness+Colour Temperature" is selected:

- **Parameter "Reaction on "off "operation"**

This parameter is for setting the sent telegram when "off" operation, you can choose only switch object send value 0, or the Brightness objects send value 0. Options:

- Only switch object send value 0
- Brightness objects send value 0

- **Parameter "Colour temperature Control type"**

This parameter is for setting the control type of colour temperature. Options:

- Normal
- Directly(with warm/cool white algorithm)

Normal: send value of 1byte brightness and 2 byte colour temperature;

Directly (with warm/cool white algorithm): directly control, it has been built-in conversion algorithm for "Brightness + Colour Temperature" and Warm/cool white brightness, that is two 1byte objects, which is used for output brightness adjustment to control warm white LED and cool white LED.

- **Parameter "Status feedback object"**

This parameter is visible when previous parameter is selected "Directly(with warm/cool white algorithm)".

Set the status feedback object. Options:

- Brightness+Colour Temperature
- Warm/cool white brightness

Brightness+Colour Temperature: feedback of Brightness+Colour Temperature is to communicate accurately with the data from the other panels.

Warm/cool white brightness: feedback of Warm/cool white brightness is to communicate with actuator

- **Parameter "Min. colour temperature [2000..7000]K"**

- **Parameter "Max. colour temperature [2000..7000]K"**

These parameters are for setting the upper and lower limit threshold of colour temperature. Options:

2000..7000

*Note: Default range is 2000K~7000K when min. value is greater than or equal to max. value.*

The following parameters are visible when "Value sender" is selected:

- **Parameter "Datatype of object"**

This parameter is for setting data type of object for value sender. Options:

- 1bit[On/Off]
- 2bit[0..3]
- 4bit[0..15]
- 1byte value
- 2byte[0..65535]
- 2byte[-32768..32767]
- 4byte[0..4294967295]
- 4byte float value

## Parameter setting description in the ETS

---

- **Parameter “Object datatype”**

This parameter is visible when previous parameter is selected “1byte value”. Set the data type of 1byte. Options:

- 1byte [0..255]
- 1byte [0..100%]

- **Parameter “Output value when press”**

This parameter is for setting the output value sent from object when press, the range of value depends on the selected data type.

- **Parameter “Long operation function”**

This parameter is not visible when previous parameter is selected “4byte...”. Set whether to enable long operation function. The following parameter is visible when enabled.

- **Parameter “Output value when long operation”**

This parameter is for setting the output value sent from object when long operation, the range of value depends on the selected data type.

The following parameters are visible when “Scene control” is selected:

- **Parameter “Output scene NO.”**

This parameter is visible when previous parameter is selected “1byte value”. Set the data type of 1byte. Options:

- 1..64

- **Parameter “Storage scene via long operation”**

This parameter is for setting whether to enable storage scene via long operation.

- **Parameter “Object with status feedback”**

This parameter is for setting whether to support the object with status feedback.

 Note: Icon name up to 10 chars., or 4 Chinese chars., or 6 Russian, Greek chars.

## Parameter setting description in the ETS

### 5.3.2 Parameter window “Room temperature control”

Parameter window “Room temperature control” as shown as Fig. 5.3.2, it is mainly about fan and room temperature control parameter setting.

--- KNX Smart Touch V50s > Function page > Page 6-...

+  General	Description for page function	<input type="text"/>
+  Home page	Page function	Room temperature control
-  Function page	Work mode	Master
Page 1-...	Temperature reference from	Internal and External sensor combination
- Page 6-...	Combination ratio	50% Internal to 50% External
Fan	Time period for request external sensor [0..255]	5 Minutes
Setpoint	Read external sensor after restart	<input checked="" type="checkbox"/>
Heating/Cooling control	Send temperature when the result change by	1.0K
Internal temperature meas...	Cyclically send temperature [0...255,0=inactive]	0 Minutes
Human Centric Lighting(H...	Control value after temp. error[0..100] (If 2-point control, set value '0'=0, set value '>0'=1)	0 %
+  Weekly timer function	Power on/off status after download	<input type="radio"/> Off <input checked="" type="radio"/> On
+  Logic function	Power on/off status after voltage recovery	As before voltage failure
+  Scene Group function	Min. set temperature[5..40]	5 °C
	Max. set temperature[5..40]	40 °C
	Control type of fan speed	1byte
- Page 6-...	Room temperature control mode	Heating and Cooling
Fan	Heating/Cooling switchover	Via both screen and object
Setpoint	Heating/Cooling status after download	<input type="radio"/> Heating <input checked="" type="radio"/> Cooling
Heating/Cooling control	Heating/Cooling status after voltage recovery	As before voltage failure
Internal temperature meas...	Room temperature control system	<input type="radio"/> 2 pipes system <input checked="" type="radio"/> 4 pipes system
Human Centric Lighting(H...	Operation mode	<input checked="" type="checkbox"/>
+  Weekly timer function	Object type of operating mode	1Byte
+  Logic function	Controller status after download	Comfort mode
+  Scene Group function	Controller status after voltage recovery	As before voltage failure
	Extended comfort mode [0..255,0=inactive]	0 Minutes
	Window contact input function	<input checked="" type="checkbox"/>
	Delay for window contact[0..65535]	15 Seconds
	Controller mode for open window	<input type="radio"/> Economy mode <input checked="" type="radio"/> Frost/heat protection

Fig. 5.3.2 (1) “Room temperature control” parameter window

## Parameter setting description in the ETS

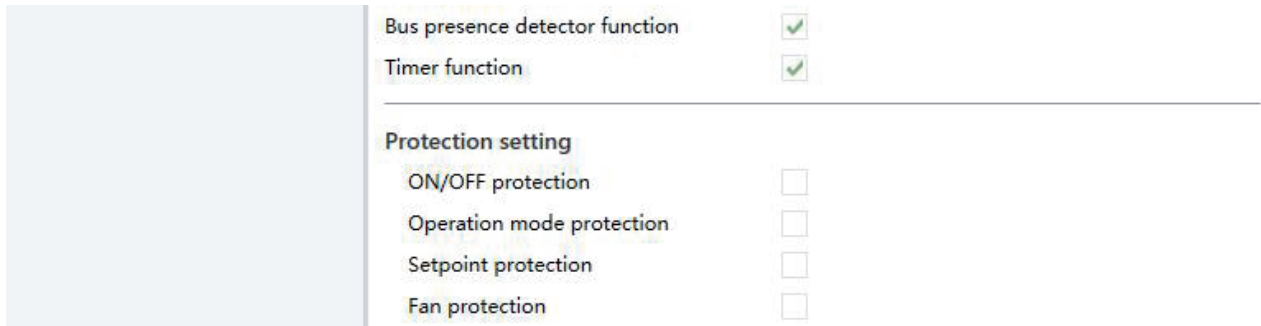

Fig. 5.3.2 (2) "Room temperature control" parameter window

### Parameter "Work mode"

This parameter is for setting the work mode of room temperature control (RTC). Options:

- Single
- Master
- Slave

Single: RTC function of the device is set to single control and with a temperature control algorithm, the output directly controls the actuator;

Master: RTC function of the device is set to multi-control and with a temperature control algorithm, the RTC output is dominated by the device. When the device restarts, it sends the current status to the bus, such as power on/off, setpoint temperature, control mode, operation mode, and fan speed read request;

Slave: RTC function of the device is set to slave control, at this time RTC is only used as touch and display, no temperature control algorithm, when the device restarts, it will send the status read request, such as power on/off, setpoint temperature, control mode, operation mode, fan speed.

### Parameter "Temperature reference from"

This parameter is for setting the resource of the RTC temperature reference. Options:

- Internal sensor
- External sensor
- Internal and External sensor combination

When selecting the reference internal sensor, the temperature is determined by the setting of the "Internal sensor" in the parameter interface.

The following parameters are visible when "Brightness+Colour Temperature" is selected:

- Parameter "Time period for request external sensor [0..255] min"

This parameter is for setting the time period for read request external temperature sensor. Options:

0..255

- Parameter "Read external sensor after restart"

This parameter is for setting whether to send read external sensor after restart.

If disabled, when the device voltage recovery or programming is completed, the read request will not occur immediately, but wait until the cycle time to send.

If enabled, when the device voltage recovery or programming is completed, a read request is sent to the external temperature sensor.

The following parameters are visible when "Internal sensor combine with External sensor" is selected:

- Parameter "Combination ratio"

This parameter is for setting the internal sensor and the external sensor to measure the specific gravity of the temperature. Options:

10% Internal to 90% External

20% Internal to 80% External

...

80% Internal to 20% External

90% Internal to 10% External

For example, if the option is "40% internal to 60% external", then the internal sensor accounts for 40%, the external sensor accounts for 60%, and the control temperature = (internal sensor's temperature × 40%) + (external sensor's temperature × 60%), the RTC function of the device will control and display the temperature according to the calculated temperature.

When two sensors are combined for detection, when one sensor is in error, the temperature value detected by the other sensor is used.

## Parameter setting description in the ETS

### Parameter “Control value after temp.error [0..100%] (If 2-point control,set value'0'=0,set value'>0'=1)”

When the work mode is “Slave”, this parameter is not visible.  
Set the control value when temperature error occur. Options:

**0..100**

If 2-Point control, then the parameter value is 0, as well as the control value; if the parameter value is more than 0, then the control value will be 1.

### Parameter “Power on/off status after download ”

When the work mode is “Slave”, this parameter is not visible.  
Set the power on/off status of RTC control interface after download. Options:

**Off**

**On**

### Parameter “Power on/off status after voltage recovery”

Parameter “Power on/off status after download ”  
Set the power on/off status of RTC control interface after device voltage recovery. Options:

**On**

**Off**

**As before voltage failure**

On: RTC control interface is on when device is powered on, this interface is operational, RTC will calculate internally according to the control type to determine the current controlling status;

Off: RTC control interface is off when device is powered on, this interface is not operational, and RTC is not going to calculate;

As before voltage failure: RTC control interface will recover to the status before voltage failure, if it is on, then RTC will calculate internally according to the control type to determine the current controlling status.

### Parameter “Min./Max. setpoint temperature [5..40]°C”

These parameters are for setting the adjustable range of the setpoint temperature, the minimum value should be less than the maximum value, if the setting temperature beyond the limited range, it will output the limited temperature. (*Note: if the min. temperature is greater than or equal to the max., default rang is 5~40°C*)

Options:

**5°C**

**6°C**

**...**

**40°C**

For setpoint temperature, the Min. value must less than the Max., if not, it can not be configured on ETS.

### Parameter “Control type of fan speed”

This parameter is for setting the object type of fan speed control. Options:

**Disable**

**1bit**

**1byte**

Disable: fan speed control is disable;

1bit: the object type of fan speed control is 1bit;

1byte: the object type of fan speed control is 1byte, at the same time, parameter window as shown in Fig.5.3.2.1.

When the work mode is “Slave”, without option 1bit.

- **Parameter “1 bit object for fan speed off ”**

This parameter is visible when previous parameter is selected 1bit. Set whether to enable 1 bit object for fan speed off.

- **Parameter “Fan speed auto”**

This parameter is visible when previous parameter is selected 1bit. Set whether to enable automatically operation of fan speed. If enabled, there will be auto level added in fan speed controlling.

## Parameter setting description in the ETS

### Parameter “Room temperature control mode”

This parameter is for setting control mode of RTC. Options:

- Heating
- Cooling
- Heating and Cooling

Heating and Cooling: heating and cooling are available. At the same time, the following parameters are visible.

- **Parameter “Heating/Cooling switchover”**

This parameter is for setting control mode of RTC. Options:

- Only via screen
- Only via object
- Via both screen and object
- Automatic changeover

When the work mode is “Slave”, read only the option **Only via object**.

- **Parameter “Heating/Cooling status after download”**

When the work mode is “Slave”, this parameter is not visible.

Set the heating/cooling control mode of device when power on RTC after download. Options:

- Heating
- Cooling

- **Parameter “Heating/Cooling status after voltage recovery”**

When the work mode is “Slave”, this parameter is not visible.

Set the heating/cooling control mode of device when power on RTC after voltage recovery. Options:

- Heating
- Cooling
- As before voltage failure

As before voltage failure: when the device is reset after power on, the control mode will recover as before voltage failure. If it is the first time the device is used or a newly enabled function page, the control mode after the device is started is in an uncertain state, and it needs to be manually selected at this time.

- **Parameter “Room temperature control system”**

When the work mode is “Slave”, this parameter is not visible.

Set the type of RTC control system, that is, pipe types of fan coil water inlet/outlet. Options:

- 2 pipes system
- 4 pipes system

2 pipes system: shares an inlet and outlet pipe for heating and cooling, that is, both hot and cold water are controlled by a valve.

4 pipes system: has its own inlet and outlet pipes for heating and cooling, and two valves are needed to control the entry and exit of hot water and cold water respectively

### Parameter “Operation mode”

This parameter is for setting whether to enable RTC operation mode.

**Parameters as follow are visible when operation mode enabled.**

- **Parameter “Object type of operating mode”**

This parameter is setting for the object type of operation mode switchover. Options:

- 4x1 Bit
- 1 Byte
- 4x1 Bit & 1 Byte

When the work mode is “Slave” or “Single”, only support the option **1 byte**.

When 4x1 Bit is selected, four 1bit objects of operation mode are visible: Comfort mode, Economy mode,

Standby mode and Frost/Heat protection mode. When one of the modes is active, the corresponding object will send the telegram “1”, otherwise the “0”. And the device will be updated to different mode according to the receiving telegrams.

When the values of the first three objects are 0, the operation mode is standby mode.

When 1byte is selected, the object “Operation mode” and “Operation mode, status” are visible, the telegrams sent are: “1” for comfort mode, “2” for standby mode, “3” for economy mode, “4” for protection mode. And the device will be updated to different mode according to the receiving telegram.

When 4x1 Bit & 1 Byte is selected, the 1bit objects and 1byte objects are both visible.

## Parameter setting description in the ETS

- **Parameter “Controller status after download**

When the work mode is “Slave”, this parameter is not visible.

- Standby mode
- Comfort mode
- Economy mode

- **Parameter “Controller status after voltage recovery”**

When the operating mode is "Slave", this parameter is not available. This parameter is used to set the operating mode of the room after turning on and resetting the device.

- Standby mode
- Comfort mode
- Economy mode
- As before voltage failure

- **Parameter “Extended comfort mode [0..255, 0=inactive] min”**

When the work mode is “Slave”, this parameter is not visible.

Set the extended time of comfort mode. When value >0, activate the extended, and 1 bit object “Extended comfort mode” is visible. Options:

0..255

When object receives telegram 1, comfort mode is activated. If receive telegram 1 again during the delay time, the time is retiming. And comfort mode will return to previous operation mode once finish the timing. Exit the comfort mode when a new operation mode in delay time.

Change the operation mode will quit the timing, and heating/cooling switchover will not.

### Parameters as follow are visible when operation mode disabled.

- **Parameter “Initial setpoint temperature (°C)”**

When the work mode is “Slave”, this parameter is not visible.

Set the initial value of setpoint temperature. Options:

- 10.0
- 10.5
- ...
- 35.0

When initial setpoint temperature is less than the min. setpoint temperature, display following warning:

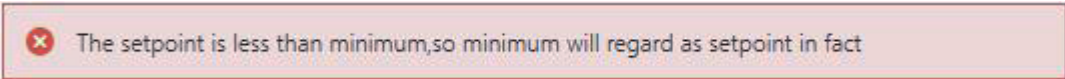

✘ The setpoint is less than minimum,so minimum will regard as setpoint in fact

When initial setpoint temperature is greater than the max. setpoint temperature, display following warning:

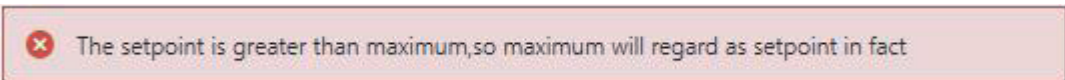

✘ The setpoint is greater than maximum,so maximum will regard as setpoint in fact

### Automatic H/C mode changeover dead zone

- **Parameter “Upper/Lower dead zone”**

When the work mode is “Slave”, these two parameters are not visible.

These two parameters are visible when control mode “Heating and Cooling” is selected, and “Automatic changeover” is selected. Setting the dead zone range of auto switchover heating/cooling. Options:

- 0.5°C
- 1.0°C
- ...
- 10.0°C

Under heating control, when the actual temperature (T) greater than or equal to the setpoint temperature + the upper dead zone, then mode heating switch to cooling;

Under cooling control, when the actual temperature (T) less than or equal to the setpoint temperature + the upper dead zone, then mode cooling switch to heating.

## Parameter setting description in the ETS

### Parameter “Window contact input function”

When the work mode is “Slave”, this parameters is not visible.

This parameter is visible when operation mode is enabled. Set whether to link to window contact status.

When window contact input function is enabled, these two parameters as follow are visible:

- **Parameter “Delay for window contact [0..65535]s”**

This parameter is visible when operation mode and window contact input function are enabled. Set the delay time to window contact detection. That is, when receive a telegram “window open”, the controller will regard that as a valid signal and execute the behaviour after this delay time. Options:

**0..65535**

- **Parameter “Controller mode for open window”**

If window status is open, perform corresponding operation according to configuration. (For the operation mode, the Switch and Setpoint temperature, as well as Heating/Cooling mode are recorded in the background if control telegrams are received, and performed after the window is closed. If there is no telegram receiving during timing, return to the mode before the window was opened.) Options:

**Economy mode**

**Frost/heat protection**

### Parameter “Bus presence detector function”

When the work mode is “Slave”, this parameter is not visible.

This parameter is visible when operation mode is enabled. Set whether to link to bus presence detector status.

If presence is detected, enter the comfort mode and it will be restored to original mode after leaving. If there is a telegram/manual operation to adjust the mode during the period, the telegram is logged in the background, and it will be exited comfort mode and restored to the mode after leaving. If there is no telegram receiving during timing, return to original mode. (If receive the presence status cyclically, comfort mode can not be re-triggered, and only can be after leaving.)

### Parameter “Timer function”

This parameter is for setting whether to enable timer function.

If the function type of current page has not been changed, no need to clear the timer configuration, if it has been changed, clear.

For example function page 6, set as Room Temperature Control at first, and it is still used as this function after downloading, keep the timer configuration; if it is configured a new function, clear the timer configuration.

If it is other function at first, then reconfigure it to Room Temperature Control, the timing is restored to the default data after the download is complete and the timing is not enabled.

## Protection setting

### Parameter “ON/OFF protection”

- **Parameter “Setpoint protection”**
- **Parameter “Operation mode protection”**
- **Parameter “Fan protection”**

These parameters are for setting to whether to enable protection function, that is some functions is only displayed, and disabled user to operate.

Protection function support to ON/OFF, setpoint value, operation mode, fan speed control.

For protection function, user can not operate screen, but still process received data.



# Parameter setting description in the ETS

## 5.3.2.1 Parameter window “Fan”

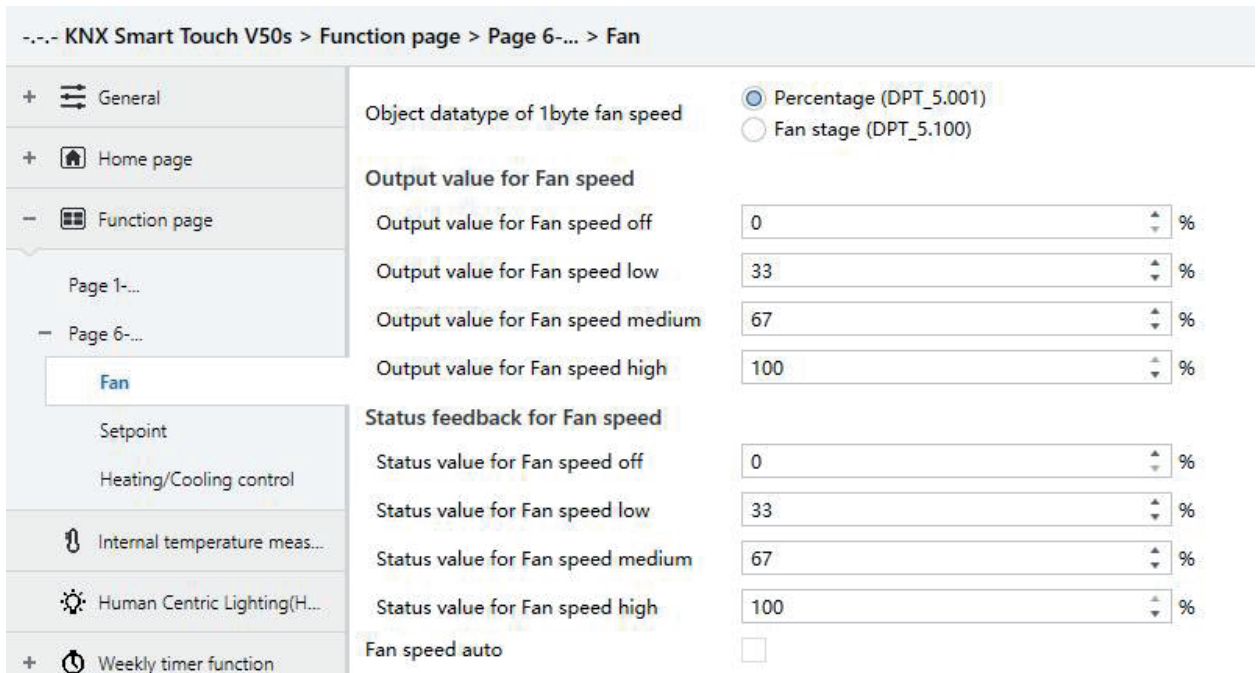

Fig. 5.3.2.1 “Fan” parameter window

This parameter window is visible when fan speed is selected “1byte”, as shown as Fig. 5.3.2.1.

### Parameter “Object datatype of 1byte fan speed”

This parameter is for setting the object datatype of 1 byte fan speed. Options:

- Fan stage (DPT 5.100)
- Percentage (DPT 5.001)

### Output value for Fan speed

#### Parameter “Output value for Fan speed off/low/medium/high”

These parameters are for setting the output value for each fan speed switchover, support 4 fan speeds: off, low, medium, high. Options according to fan object datatype:

0..255/0..100

### Status feedback for Fan speed

#### Parameter “Status value for Fan speed off/low/medium/high”

These parameters are for setting the status feedback value for each fan speed, support 4 fan speeds: off, low, medium, high. Device will be updated display according to the feedback value. Options according to fan object datatype:

0..255/0..100

*Note: the out value and status value must meet the condition off<low<medium<high, if not, they can not be configured on ETS, and display red box warning, as shown as follow:*

Output value for Fan speed off	0	%
Output value for Fan speed low	68	%
Output value for Fan speed medium	67	%
Output value for Fan speed high	100	%

### Parameter “Fan speed auto”

This parameter is for setting whether to enable fan speed auto function, display corresponding object when enable.

## Parameter setting description in the ETS

### 5.3.2.2 Parameter window "Setpoint"

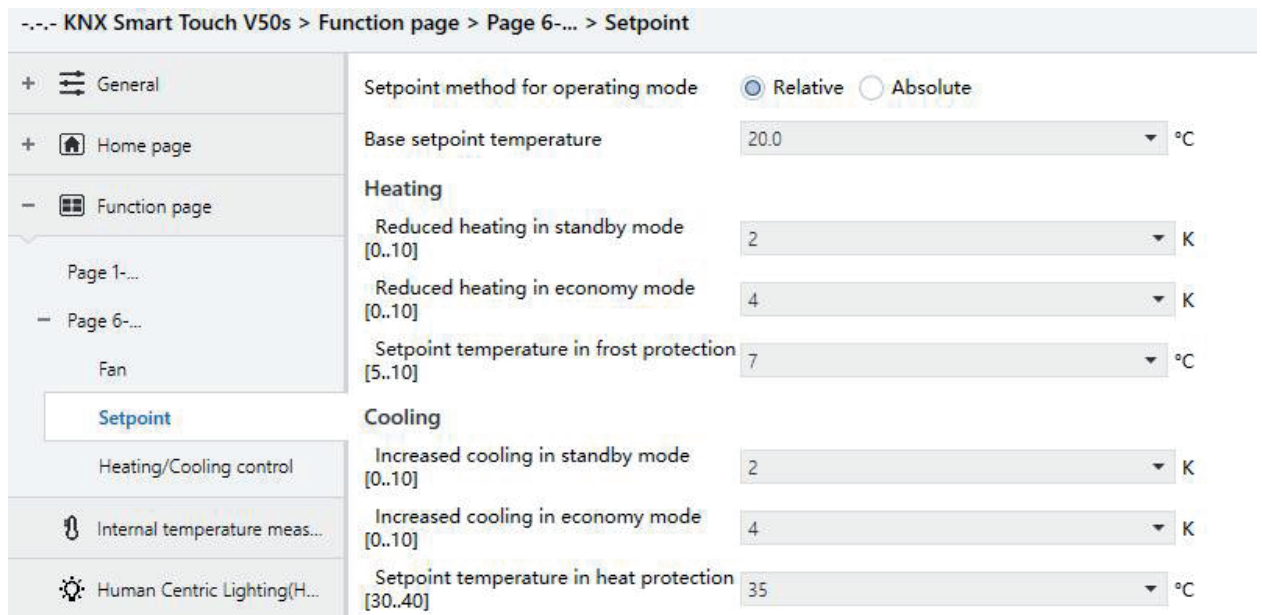

Fig. 5.3.2.2(1) "Setpoint\_Relative" Parameter window

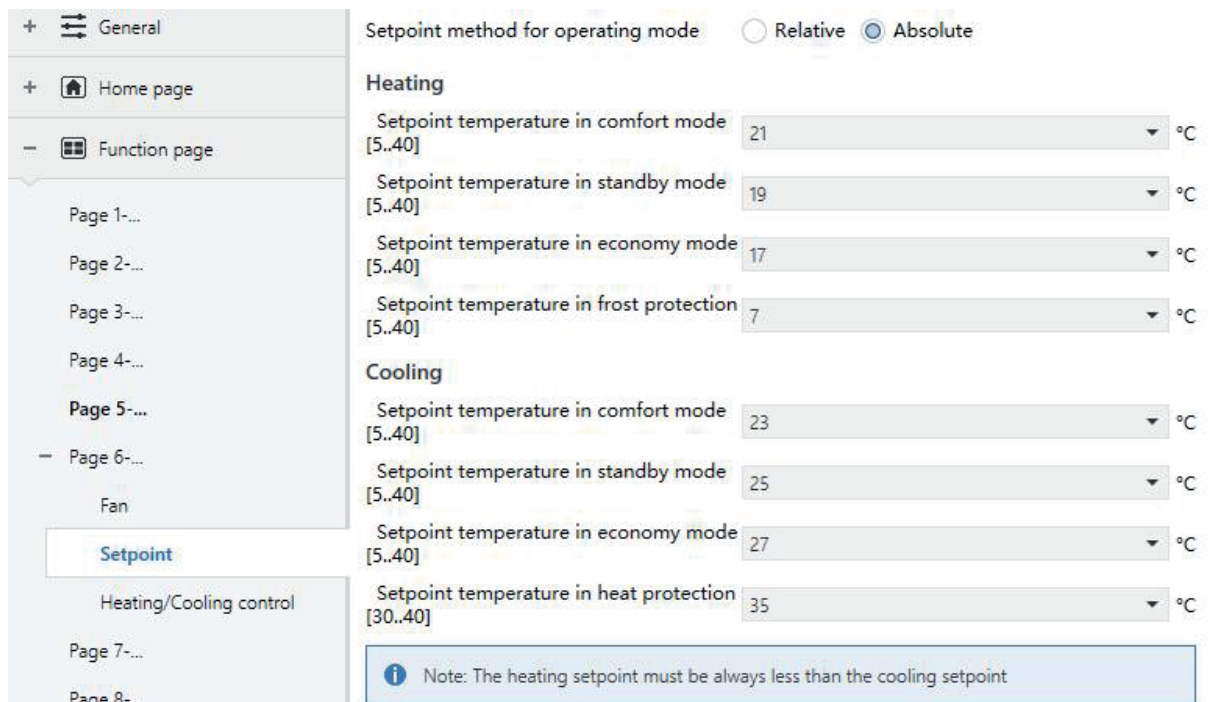

Fig. 5.3.2.2(2) "Setpoint\_Absolute" Parameter window

When the work mode is "Slave", this parameter window is not visible.  
 This parameter window is visible when operation mode is enabled, and display according to control mode.

#### Parameter "Setpoint method for operating mode"

This parameter is for setting the setpoint method for operating mode. Options:

- Relative
- Absolute

Relative: the setpoint temperature of economy mode and standby mode will refer to the defined base setpoint temperature.  
 Absolute: each mode has its independent temperature setpoint value.

## Parameter setting description in the ETS

Parameters as follow are visible when the setpoint temperature adopts the relative adjustment method.

### Parameter "Base setpoint temperature(°C)"

This parameter is for setting the base setpoint temperature, from which the setpoint temperature of the room comfort mode is obtained. Options:

10.0°C

10.5°C

...

35.0°C

The setpoint value will be modified through object "Current setpoint adjustment", then the new value will be stored after the device power off.

When base setpoint temperature is less than the min. setpoint temperature, display following warning:

 The setpoint is less than minimum,so minimum will regard as setpoint in fact

When base setpoint temperature is less than the min. setpoint temperature, display following warning:

 The setpoint is greater than maximum,so maximum will regard as setpoint in fact

### Automatic H/C mode changeover dead zone (only for comfort mode)

#### Parameter "Upper/Lower dead zone"

These two parameters are visible when control mode "Heating and Cooling" and "Automatic changeover" are selected. Set the dead zone range of auto switchover heating/cooling. Options:

0.5°C

1.0°C

...

10.0°C

Under heating control, when the actual temperature (T) greater than or equal to the setpoint temperature + the upper dead zone, then mode heating switch to cooling;

Under cooling control, when the actual temperature (T) less than or equal to the setpoint temperature + the lower dead zone, then mode cooling switch to heating.

#### Parameter "Reduced heating in standby mode [0..10]°C"

#### Parameter "Increased cooling in standby mode [0..10]°C"

These two parameters are for setting the setpoint of standby mode. Options:

0°C

1°C

...

10°C

Heating: the setpoint of standby mode is the temperature setpoint minus the reference value;

Cooling: the setpoint of standby mode is the temperature setpoint plus the reference value.

#### Parameter "Reduced heating during economy mode [0..10]°C"

#### Parameter "Increased cooling during economy mode [0..10]°C"

These two parameters are for setting the setpoint of economy mode. Options:

0°C

1°C

...

10°C

Heating: the setpoint of economy mode is the temperature setpoint minus the reference value;

Cooling: the setpoint of economy mode is the temperature setpoint plus the reference value.

## Parameter setting description in the ETS

### Parameter "Setpoint temperature in frost protection mode [5...40]°C" (for Heating)

This parameter is for setting the setpoint of frost protection mode. Options:

5°C  
6°C  
...  
40°C

Under the frost protection mode, when room temperature reduce to the setpoint, the controller will trigger a control telegram so that related heating controller will output heating control to prevent the temperature from being too low.

### Parameter "Setpoint temperature in heat protection mode [30...40]°C" (for Cooling)

This parameter is for setting the setpoint of heat protection mode. Options:

30°C  
31°C  
...  
40°C

Under the heat protection mode, when room temperature raise to the setpoint, the controller will trigger a control telegram so that related cooling controller will output cooling control to prevent the temperature from being too high.

Parameters as follow are visible when the setpoint temperature adopts the absolute adjustment method.

- Parameter "Setpoint temperature in comfort mode [5...40]°C"
- Parameter "Setpoint temperature in standby mode [5...40]°C"
- Parameter "Setpoint temperature in economy mode [5...40]°C"

These parameters are for setting the setpoint temperature in comfort, standby and economy mode when heating or cooling. Options:

5°C  
6°C  
...  
40°C

### Parameter "Setpoint temperature in frost protection mode [5...40]°C"

This parameter is for setting the setpoint temperature in frost protection mode when heating. Options:

5°C  
6°C  
...  
40°C

### Parameter "Setpoint temperature in heat protection mode [30...40]°C"

This parameter is for setting the setpoint temperature in heat protection mode when cooling. Options:

30°C  
31°C  
...  
40°C

 Note: The heating setpoint must be always less than the cooling setpoint.

For absolute adjustment mode, "Heating and Cooling" is selected, whether it is manual changeover, bus changeover or automatic changeover, the heating setpoint value must be less than or equal to the cooling of the same operation mode, if not, it can not be configured on ETS.

1. When the ambient temperature is higher than the setpoint temperature of current mode, it is changed to cooling mode; When the ambient temperature is lower than the setpoint temperature of current mode, it is changed to heating mode.
2. In the same operation mode, the setpoint temperature difference between cooling and heating remains constant, whether it is written on the bus or adjusted on the panel. That is, when adjust the setpoint temperature, it need to update cooling and heating setpoint temperature of current operation mode at the same time.

## Parameter setting description in the ETS

3. When user operates on the panel or the bus is received setpoint temperature, it is still necessary to limit the value according to the high and low thresholds, that is heating and cooling temperature neither can not be lower than the min., or can not be higher than the max.. If parameters configuration of ETS is not met the condition, it will be noted warnings:

When the setpoint temperature of comfort/standby/economy mode is less than the min. setpoint temperature, display following warning:

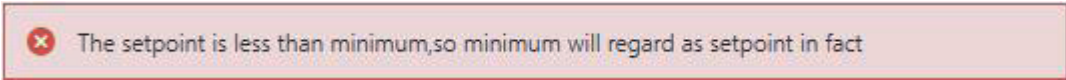

When the setpoint temperature of comfort/standby/economy mode is greater than the max. setpoint temperature, display following warning:

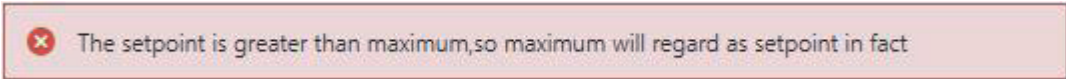

*Note: for relative/absolute adjustment, in protection mode, the setpoint temperature is only configured via ETS, and not limited with the min./max. value, and user can not change it on screen.*

### 5.3.2.3 Parameter window “Heating/Cooling control”

--- KNX Smart Touch V50s > Function page > Page 6-... > Heating/Cooling control

<ul style="list-style-type: none"> <li>+  General</li> <li>+  Home page</li> <li>-  Function page</li> <li style="padding-left: 20px;">Page 1-...</li> <li style="padding-left: 20px;">- Page 6-...</li> <li style="padding-left: 40px;">Fan</li> <li style="padding-left: 40px;">Setpoint</li> <li style="padding-left: 20px; background-color: #e0e0e0;">Heating/Cooling control</li> </ul>	<p>Type of heating control: Switching on/off(use 2-point control)</p> <p>Invert control value: <input type="checkbox"/></p> <p>Lower Hysteresis[0..200]: 20 *0.1K</p> <p>Upper Hysteresis[0..200]: 20 *0.1K</p> <hr/> <p>Type of cooling control: Switching on/off(use 2-point control)</p> <p>Invert control value: <input type="checkbox"/></p> <p>Lower Hysteresis[0..200]: 20 *0.1K</p> <p>Upper Hysteresis[0..200]: 20 *0.1K</p> <hr/> <p>Cyclically send control value[0..255]: 0 Minutes</p> <p>Parameter setting of “Switching on/off (use 2-point control)”</p>
<ul style="list-style-type: none"> <li>+  General</li> <li>+  Home page</li> <li>-  Function page</li> <li style="padding-left: 20px;">Page 1-...</li> <li style="padding-left: 20px;">- Page 6-...</li> <li style="padding-left: 40px;">Fan</li> <li style="padding-left: 40px;">Setpoint</li> <li style="padding-left: 20px; background-color: #e0e0e0;">Heating/Cooling control</li> <li style="padding-left: 20px;">Internal temperature meas...</li> <li style="padding-left: 20px;">Human Centric Lighting(H...</li> <li>+  Weekly timer function</li> <li>+  Loic function</li> </ul>	<p>Type of heating control: Switching PWM(use PI control)</p> <p>Invert control value: <input type="checkbox"/></p> <p>PWM cycle time[1..255]: 15 Minutes</p> <p>Heating speed: User defined</p> <p>Proportional range[10..100]: 40 *0.1K</p> <p>Reset time[0..255]: 150 Minutes</p> <hr/> <p>Type of cooling control: Switching PWM(use PI control)</p> <p>Invert control value: <input type="checkbox"/></p> <p>PWM cycle time[1..255]: 15 Minutes</p> <p>Cooling speed: User defined</p> <p>Proportional range[10..100]: 40 *0.1K</p> <p>Reset time[0..255]: 150 Minutes</p> <hr/> <p>Cyclically send control value[0..255]: 0 Minutes</p> <p>Parameter setting of “Switching PWM (use PI control)”</p>



## Parameter setting description in the ETS

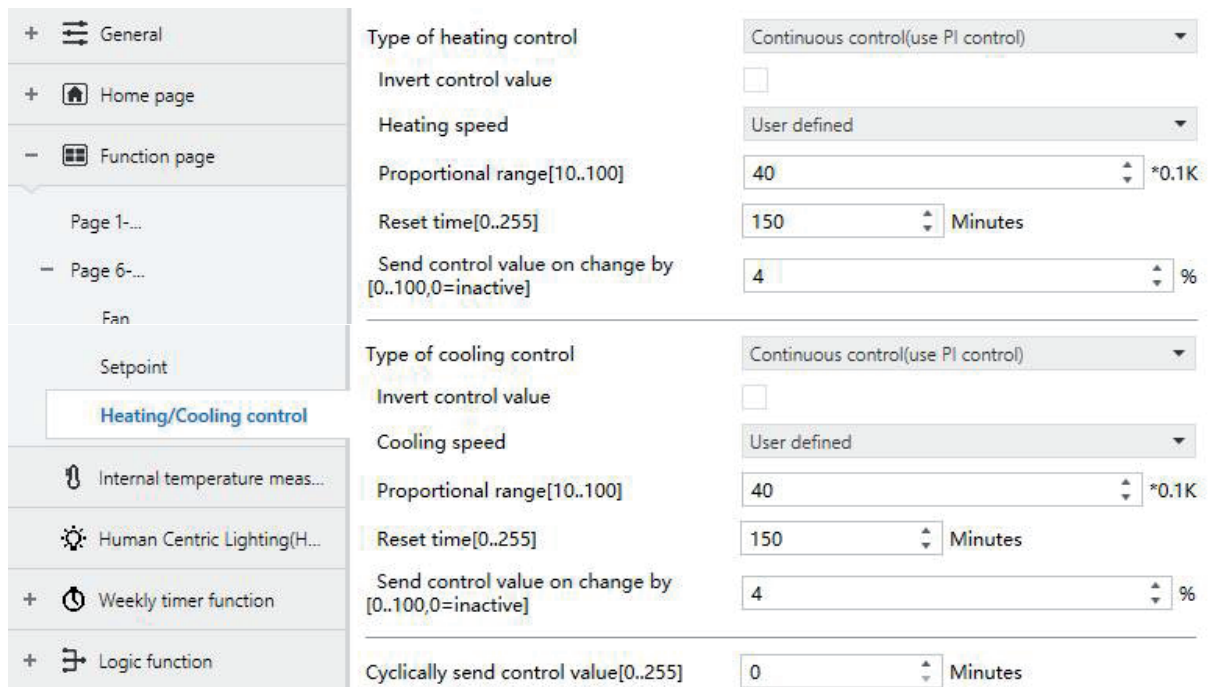

Parameter	Value	Unit
Type of heating control	Continuous control (use PI control)	
Invert control value	<input type="checkbox"/>	
Heating speed	User defined	
Proportional range [10..100]	40	*0.1K
Reset time [0..255]	150	Minutes
Send control value on change by [0..100, 0=inactive]	4	%
Type of cooling control	Continuous control (use PI control)	
Invert control value	<input type="checkbox"/>	
Cooling speed	User defined	
Proportional range [10..100]	40	*0.1K
Reset time [0..255]	150	Minutes
Send control value on change by [0..100, 0=inactive]	4	%
Cyclically send control value [0..255]	0	Minutes

### Parameter setting of "Continuous control (use PI control)"

Fig. 5.3.2.3(1) "Heating/Cooling control" parameter window

When the work mode is "Slave", this parameter window is not visible.

This parameter window displays according to control mode and control system (2 pipe or 4 pipe).

### Parameter "Type of heating/cooling control"

This parameter is for setting the type of heating/cooling control. Different control types are suitable for controlling different temperature controllers. Options:

- Switching on/off (use 2-point control)
- Switching PWM (use PI control)
- Continuous control (use PI control)

### Parameter "Invert control value"

This parameter is for setting whether to invert control value or normal sending control value, so that the control value will be suitable for the valve type. When enabled, send the control value to the bus through objects after inverting the control value.

These two parameters as follow are suitable for 2 point control:

- Parameter "Lower Hysteresis [0...200]\*0.1°C "
- Parameter "Upper Hysteresis [0...200]\*0.1°C"

These two parameters are for setting the lower/upper hysteresis temperature in RTC heating or cooling. Options:

0..200

Under heating control,

When the actual temperature (T) > the setting temperature + the upper hysteresis temperature, then will stop heating;

When the actual temperature (T) < the setting temperature - the lower hysteresis temperature, then will start heating.

For example, the lower hysteresis temperature is 1K, the upper hysteresis temperature is 2K, the setting temperature is 22°, if T is higher than 24°, then it will stop heating; if T is lower than 24°, then it will start heating; if T is between 21~24°, then it will maintain the previous status.

Under the cooling control,

When the actual temperature (T) < the setting temperature - the lower hysteresis temperature, then will stop cooling;

When the actual temperature (T) > the setting temperature + the upper hysteresis temperature, then will start cooling.

For example, the lower hysteresis temperature is 1°C, the upper hysteresis temperature is 2°C, the setting temperature is 26°, if T is lower than 25°, then it will stop cooling; if T is lower than 28°, then it will start cooling; if T is between 28~25°, then it will maintain the previous status.

Parameter setting description in the ETS

2-point control mode is a very simple control mode. When adopting this control mode, it is necessary to set the upper hysteresis temperature and the lower hysteresis temperature through parameters. When setting the hysteresis temperature, the following effects need to be considered:

1. When hysteresis interval is small, the temperature range will be small, however, frequent sending of control value will bring large load to the bus;
2. When hysteresis interval is large, the switch switching frequency will be low, but it is easy to cause uncomfortable temperature change.

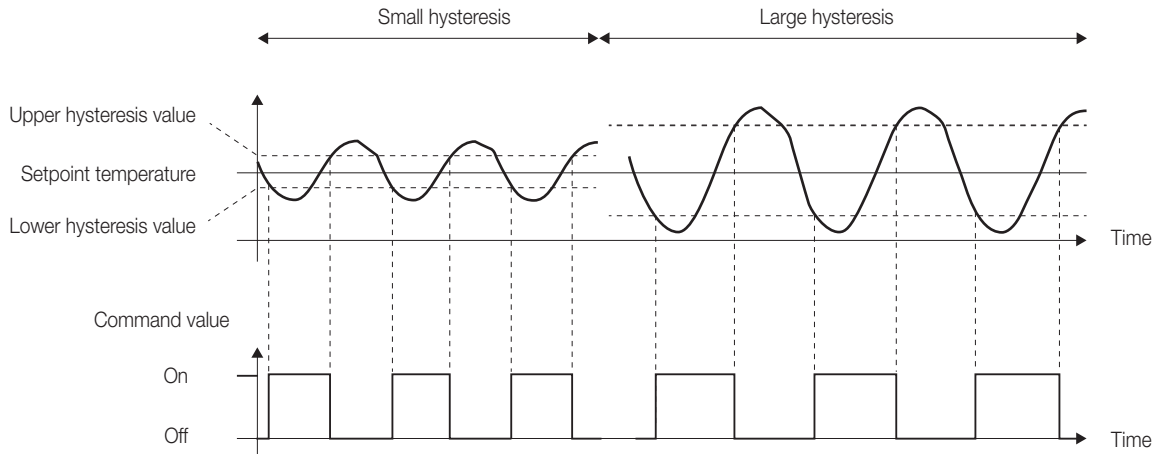

Fig. 5.3.2.3(2) Effects of hysteresis on control value switch action(heating) under 2-point control mode

These two parameters as follow are suitable for PI control:

**Parameter “Heating speed ”**

• Parameter “Cooling speed”

These parameters are for setting the responding speed of heating or cooling controller. Different responding speeds are suitable for different environments. Options:

- Hot water heating (5°C/150min)
- Underfloor heating (5°C/240min)
- Electrical heating (4°C/100min)
- Split unit/Fan coil unit (4°C/90min)
- User defined

Options:

- Cooling ceiling (5°C/240min)
- Split unit (4°C/90min)
- Fan coil unit(4°C/90min)
- User defined

• Parameter “Proportional range [10..100]\*0.1°C”(P value)

• Parameter “Reset time [0..255]min”(I value)

These two parameters are visible when “User defined” is selected. Set the PI value of PI controller.

Options:

- 10..100 (P value)
- 0..255 (I value)

**Parameter “PWM cycle time [1..255] min”**

This parameter is only visible when the control type is “Switching PWM (use PI control)”. For setting the period of the control object cycle to send the switch value, the object sends the switch value according to the duty cycle of the control value. For example, if the set period is 10 min and the control value is 80%, then the object will send an on telegram for 8 min and an off telegram for 2 min. If the control value is changed, the time duty ratio of the on/ off telegram of the object will also change, but the period is still the time of parameter setting. Options:

1...255

The PI values of “Switching PWM (use PI control)” and “Continuous control (use PI control)” are the same, only different in control objects, the control object of “Continuous control” output PI value(1byte) directly, while the control value of “Switching PWM” output a “on/off” telegram according to the duty cycle of the control value.

## Parameter setting description in the ETS

### Parameter "Send control value on change by [0..100%, 0=inactive]"

This parameter is visible when control type is "Continuous control (use PI control)". Set the changing value of the control value to be sent to the bus. Options:

0..100, 0 = inactive

### Parameter "Cyclically send control value [0..255]min"

This parameter is for setting the period for cyclically sending the control value to the bus. Options:

0..255

In PI control mode, the predefined control parameters of each PI controller in heating or cooling system are recommended as follows:

#### (1) Heating

Heating type	P value	I value (integration time)	Recommended PI control type	Recommended PWM period
Hot water Heating	5K	150min	Continuous/PWM	15min
Underfloor heating	5K	240min	PWM	15-20min
Electrical heating	4K	100min	PWM	10-15min
Split unit	4K	90min	PWM	10-15min
Fan coil unit	4K	90min	Continuous	--

#### (2) Cooling

Cooling type	P value	I value (integration time)	Recommended PI control type	Recommended PWM period
Cooling ceiling	5K	240min	PWM	15-20min
Split unit	4K	90min	PWM	10-15min
Fan coil unit	4K	90min	Continuous	--

#### (3) User defined

When the parameter "Heating/Cooling speed" is set to "User defined", the parameter value of P (scale factor) and I (integration time) can be set through the parameter. When adjusting the parameters, refer to the fixed PI value mentioned in the above table. Even if the control parameters are adjusted slightly, the control behavior will be significantly different.

In addition, the integration time should be set properly. If the integration time is too long, the adjustment will be slow, and the oscillation will not be obvious; if the integration time is too small, the adjustment will be fast, but the oscillation will occur. 0 means the integral term is not used.

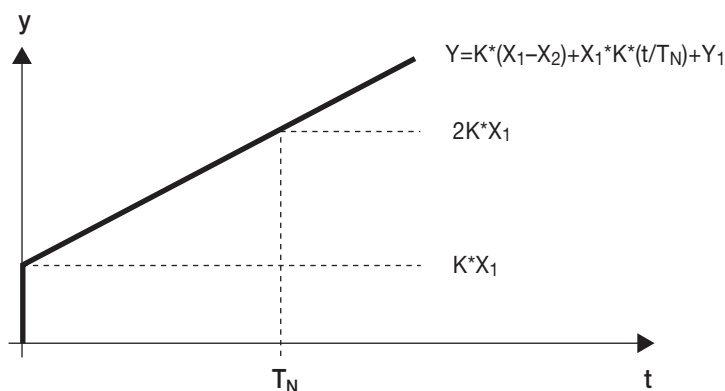

Fig. 5.3.2.3(3) control value of PI control mode

Y: control value

Y1: last control value

X1: temperature deviation = set temperature - actual temperature

X2: last temperature deviation = set temperature - actual temperature

TN: integration time

K: scale factor (the scale factor is not zero)

PI control algorithm:  $Y = K * (X1-X2) + X1 * K * t / TN + Y1$

When the integration time is set to zero, the PI control algorithm is:  $Y = K * (X1-X2) + Y2$



## Parameter setting description in the ETS

Setting and influence of user-defined parameters:

Parameter setting	Effect
K: If the scale range is too small	Quick adjustment, and overshoot will occur
K: If the scale range is too small	Slow adjustment, but no overshoot
TN: If the integration time is too short	Quick adjustment, but there will be oscillation
TN: If the integration time is too long	Slow adjustment, no obvious oscillation

### 5.3.3 Parameter window “Air conditioner”

Parameter window “Air conditioner” as shown as Fig. 5.3.3, for setting Air conditioner control.

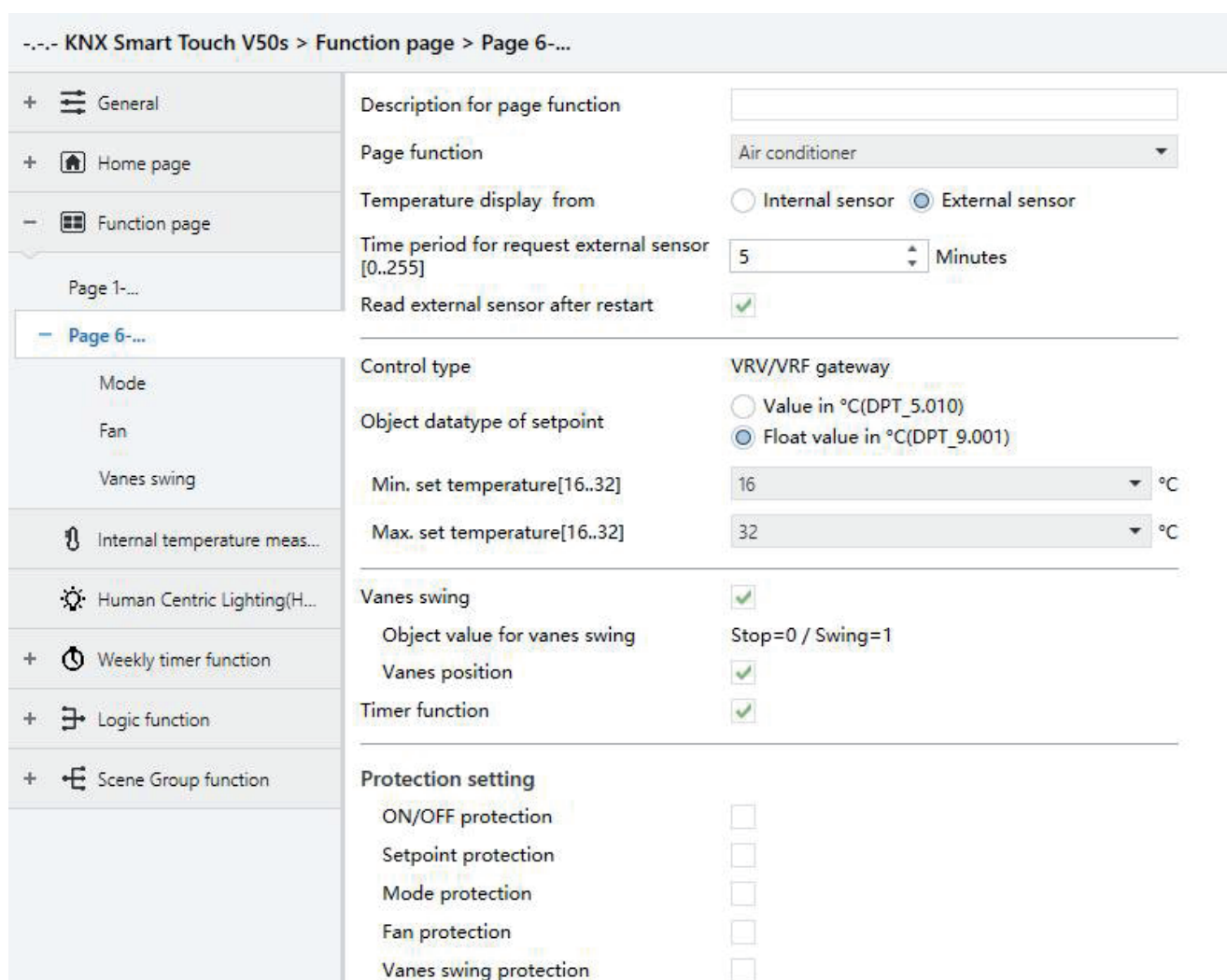

Fig. 5.3.3 “Air conditioner” parameter window

#### Parameter “Temperature display from”

This parameter is for setting the resource of air conditioner temperature reference. Options:

- Internal sensor
- External sensor

When selecting the reference internal sensor, the temperature is determined by the setting of the “Internal sensor” in the parameter interface.

Temperature setting of air conditioner is similar to RTC (except for the temperature measurement option without combination sensor), detail please refer to section 5.3.2.

## Parameter setting description in the ETS

### Parameter “Time period for request external sensor [0..255]min”

This parameter is visible when “External sensor” is selected. Set the time period for read request external temperature sensor. Options:  
0..255

### Parameter “Read external sensor after restart”

This parameter is visible when “External sensor” is selected. Set whether to send read external sensor after restart.

### Parameter “Control type”

This parameter is for setting the control type of air conditioner. Option is only read **VRV/VRF gateway**:

### Parameter “Object datatype of setpoint”

This parameter is for setting the object data type of setpoint temperature. Options:

Value in °C (DPT_5.010)	Int, data of actual temperature
Float value in °C (DPT_9.001)	Float, data of standard KNX temperature

### Parameter “Min./Max. setpoint temperature [16..32]°C”

These parameters are for setting the adjustable range of the setpoint temperature, the minimum value should be less than the maximum value, if the setting temperature beyond the limited range, it will output the limited temperature. (**Note: if the min. temperature is greater than or equal to the max., default range is 16~32°.**) Options:

16°C  
17°C  
...  
32°C

For setpoint temperature, the Min. value must less than the Max., if not, it can not be configured on ETS.

### Parameter “Vanes swing”

This parameter is for setting whether to enable vanes swing function, display corresponding parameters and objects after it is enabled.

- Parameter “Object value for vanes swing”

This parameter is visible when previous is enabled. Set the object value for vanes swing, it is only read **Stop=0/Swing=1**

- Parameter “Vanes position”

This parameter is visible when previous is enabled. Set whether to enable vanes position, display corresponding parameters and objects after it is enabled.

### Parameter “Timer function”

This parameter is for setting whether to enable timer function, display corresponding object after it is enabled, and user can set the timing on the screen

### Parameter “ON/OFF protection”

- Parameter “Setpoint protection”
- Parameter “Mode protection”
- Parameter “Fan protection”
- Parameter “Vanes swing protection”

These parameters are for setting to whether to enable protection function, that is some functions only display and disable user to operate.

Protection function support to ON/OFF, setpoint value, mode, fan speed control, vanes swing control. And vanes swing control need to be enabled before its protection can be displayed.

For protection function, user can not operate screen, but still process received data.

## Parameter setting description in the ETS

### 5.3.3.1 Parameter window “Mode”

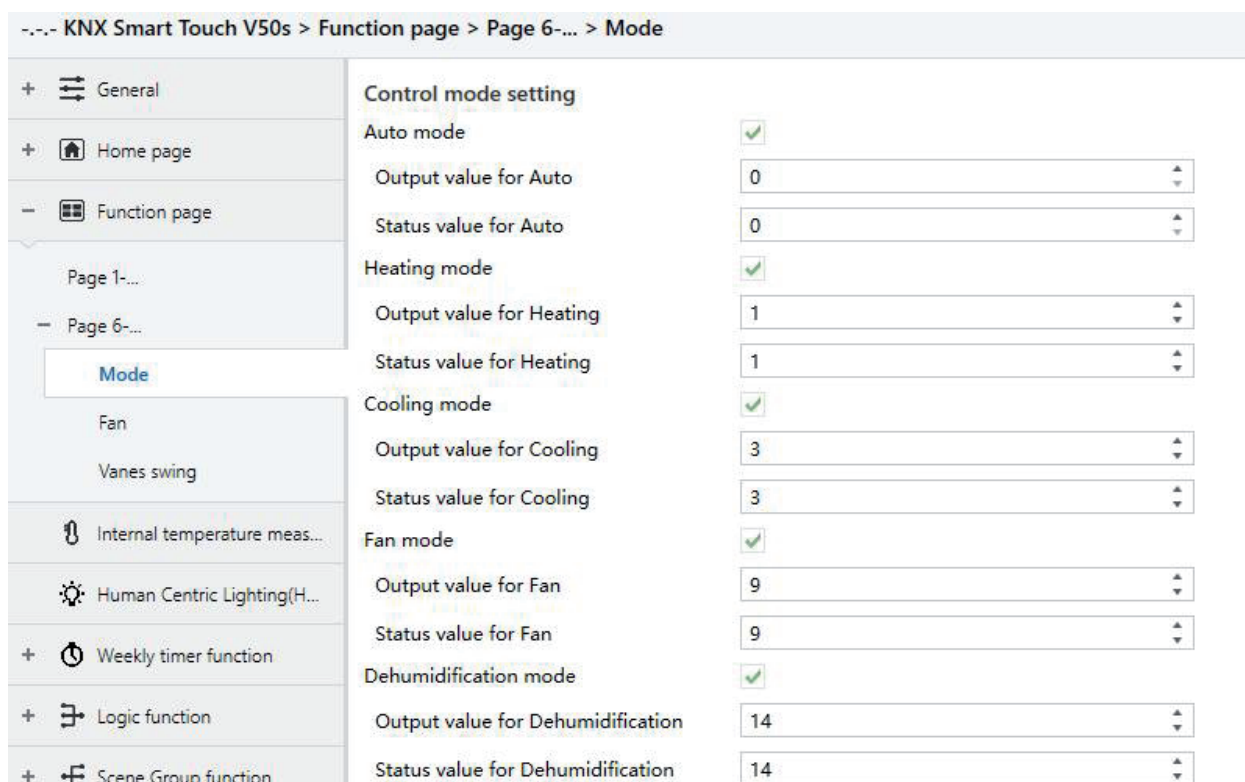

Fig. 5.3.3.1 “Mode” parameter window

#### Parameter “Auto/Heating/Cooling/Fan/Dehumidification mode”

Corresponding setting parameters are visible when these parameters are enabled.

#### Parameter “Output value for Auto/Heating/Cooling/Fan/Dehumidification”

These parameters are visible when modes enabled. Set the output value of each mode. Options:

0..255

#### Parameter “Status value for Auto/Heating/Cooling/Fan/Dehumidification”

These parameters are visible when modes enabled. Set the status feedback value of each mode. Options:

0..255

## Parameter setting description in the ETS

### 5.3.3.2 Parameter window “Fan”

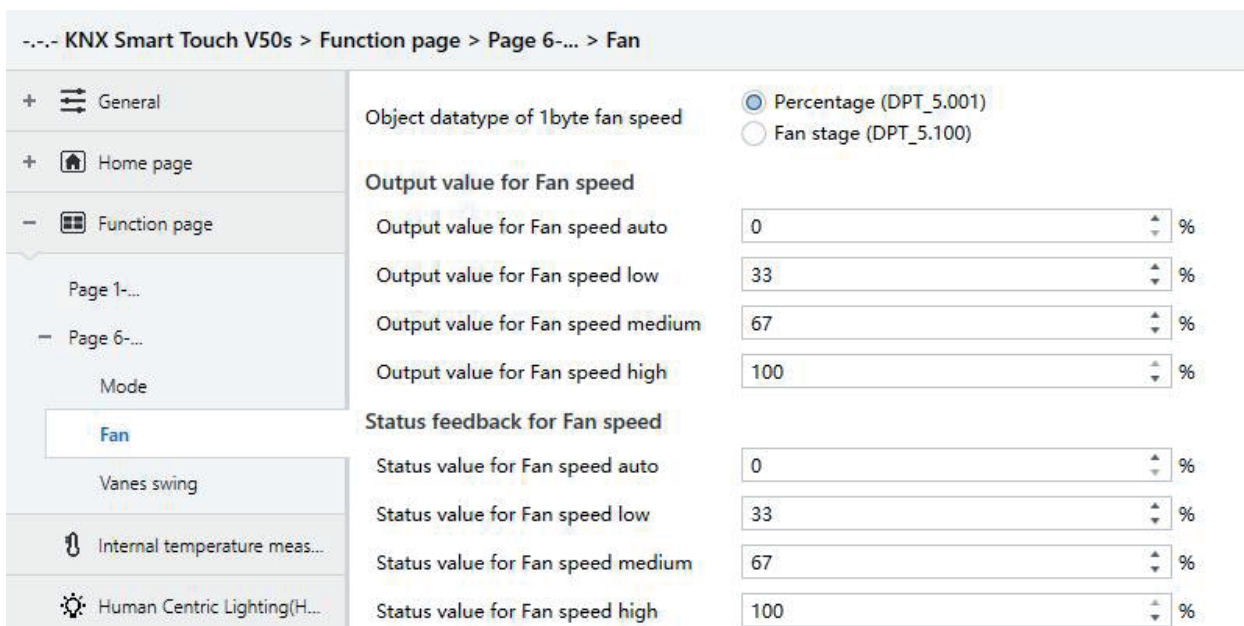

Fig. 5.3.3.2 “Fan” parameter window

#### Parameter “Object datatype of 1byte fan speed”

This parameter is for setting the object datatype of 1 byte fan speed. Options:

- Fan stage (DPT 5.100)
- Percentage (DPT 5.001)

#### Output value for fan speed

#### Parameter “Output value for fan speed auto/low/medium/high”

These parameters are for setting the value sent for each fan speed switchover, support 4 fan speeds: auto, low, medium, high. Options according to fan object datatype: 10.0°C

0..255/0..100

#### Status feedback for fan speed

#### Parameter “Status value for fan speed auto/low/medium/high”

These parameters are for setting the status feedback value for each fan speed, support 4 fan speeds: auto, low, medium, high. Device will be updated display according to feedback value. Options according to fan object datatype:

0..255/0..100

**Note:** the out value and status value must meet the condition low < medium < high, if not, they can not be configured on ETS, and display red box warning, as shown as follow:

Output value for Fan speed off	0	%
Output value for Fan speed low	68	%
Output value for Fan speed medium	67	%
Output value for Fan speed high	100	%

## Parameter setting description in the ETS

### 5.3.3.3 Parameter window “Vanes swing”

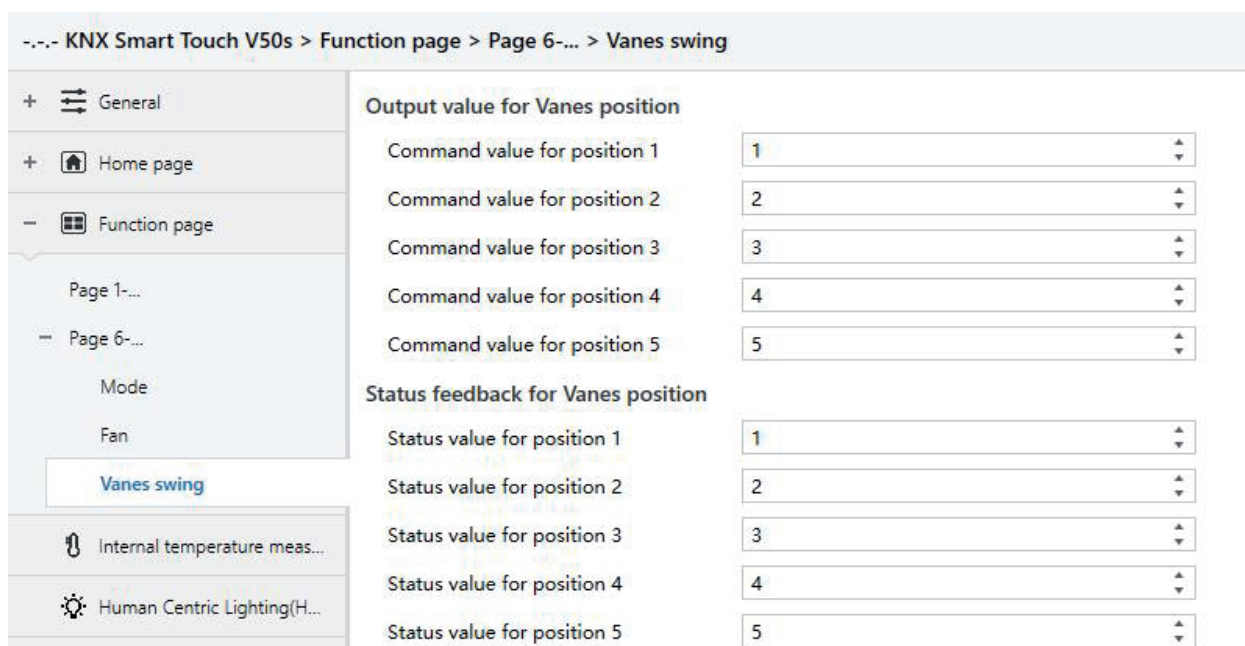

Fig. 5.3.3.3 “Vanes swing” parameter window

This parameter window is visible when vanes position is enabled, optional 5 positions.

#### Output value for Vanes position

The following parameters for setting the value sent by object “Vanes position 1..5, status” when switch to each vanes position.

##### Parameter “Command value for position 1/2/3/4/5”

These parameters define the corresponding command value of the 5 vanes positions. Options:

0..255

#### Status feedback for Vanes position

The following parameters setting for the status feedback value of all vanes positions..

##### Parameter Status value for position 1/2/3/4/5”

These parameters setting for the status feedback value of each vanes position, the device will update the icon status of vanes position according to the feedback value received. Options:

0..255

## Parameter setting description in the ETS

### 5.3.4 Parameter window “Audio control”

Parameter window “Audio control” as shown as Fig. 5.3.4, for setting background music control.

When the function is selected, objects for audio control are visible, such as power on/off, Play/Pause, volume control, Next song/Previous song, play mode, etc. Through these objects can control background music module.

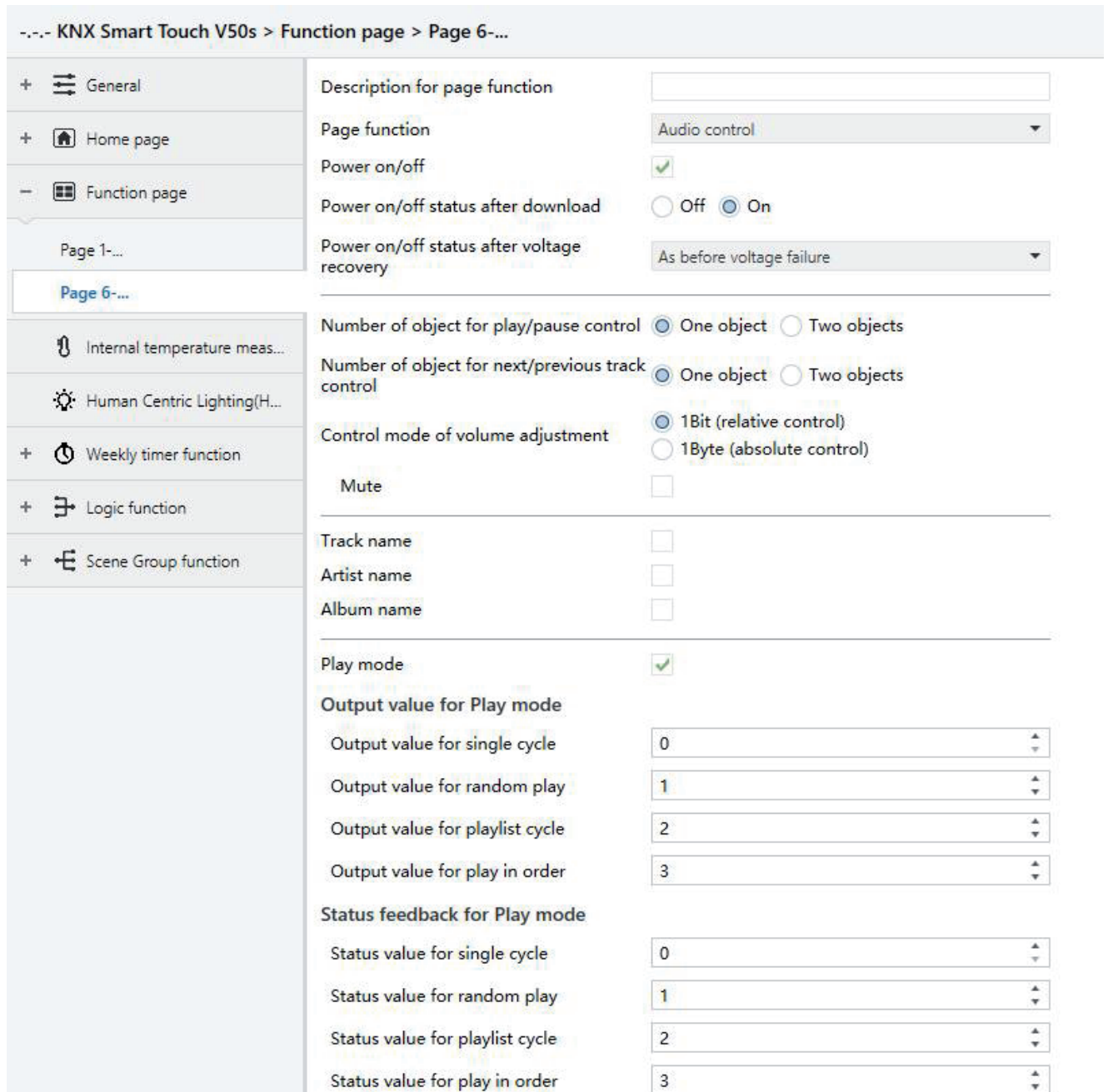

--- KNX Smart Touch V50s > Function page > Page 6-...









+  General	Description for page function	<input type="text"/>
+  Home page	Page function	Audio control <input type="text"/>
-  Function page	Power on/off	<input checked="" type="checkbox"/>
Page 1-...	Power on/off status after download	<input type="radio"/> Off <input checked="" type="radio"/> On
Page 6-...	Power on/off status after voltage recovery	As before voltage failure <input type="text"/>
 Internal temperature meas...	Number of object for play/pause control	<input checked="" type="radio"/> One object <input type="radio"/> Two objects
 Human Centric Lighting(H...	Number of object for next/previous track control	<input checked="" type="radio"/> One object <input type="radio"/> Two objects
+  Weekly timer function	Control mode of volume adjustment	<input checked="" type="radio"/> 1Bit (relative control) <input type="radio"/> 1Byte (absolute control)
+  Logic function	Mute	<input type="checkbox"/>
+  Scene Group function	Track name	<input type="checkbox"/>
	Artist name	<input type="checkbox"/>
	Album name	<input type="checkbox"/>
	Play mode	<input checked="" type="checkbox"/>
	Output value for Play mode	
	Output value for single cycle	<input type="text" value="0"/>
	Output value for random play	<input type="text" value="1"/>
	Output value for playlist cycle	<input type="text" value="2"/>
	Output value for play in order	<input type="text" value="3"/>
	Status feedback for Play mode	
	Status value for single cycle	<input type="text" value="0"/>
	Status value for random play	<input type="text" value="1"/>
	Status value for playlist cycle	<input type="text" value="2"/>
	Status value for play in order	<input type="text" value="3"/>

Fig. 5.3.4 “Audio control” parameter window

#### Parameter “Power on/off”

This parameter is for setting whether to activate the function to power on/off. Icon of power on/off on the screen is not visible when disabled.

#### Parameter “Power on/off after download ”

This parameter is for setting the power on/off status of audio control interface after download. Options:

- Off
- On

## Parameter setting description in the ETS

### Parameter “Power on/off after voltage recovery”

This parameter is for setting the power on/off status of audio control interface after device voltage recovery. Options:

**On**

**Off**

**As before voltage failure**

On: device will power on when voltage recovery, this interface can be operated;

Off: device will power off when voltage recovery, this interface can not be operated;

Before voltage failure: device will return to the power status as before voltage failure when voltage recovery.

### Parameter “Number of object for play/pause control”

This parameter is for setting the number of objects that control play/pause, 1 common object or 2 separate objects. Options:

**One object**

**Two objects**

### Parameter “Number of object for next/previous track control”

This parameter is for setting the number of objects that control next/previous track, 1 common object or 2 separate objects. Options:

**One object**

**Two objects**

### Parameter “Control mode of volume adjustment”

This parameter is for setting the datatype of volume adjustment. Options:

**1Bit (relative control)**

**1Byte (absolute control)**

When 1 bit, support to increase/decrease volume and mute function; When 1 byte, only support 1byte object to adjust volume, and you can set the maximum volume.

### Parameter “Object datatype”

This parameter is visible when 1byte is selected. Set the datatype of 1byte object. Options:

**Percentage (DPT 5.001)**

**Percentage (DPT 5.004)**

### Parameter “Max. volume value [10..100]”

This parameter is visible when 1byte is selected. Set the maximum volume value. Options:

**10..100**

### Parameter “Mute”

This parameter is visible when 1bit is selected. Set whether to enable mute function.

### Parameter “Track name”

This parameter is for setting whether to display the track name.

**Note:** The encode data of track name telegram is associated with interface language, when it is selected Simplified Chinese, use UTF-8; while other languages, use ISO8859. The telegrams of artist name and album name are the same.



## Parameter setting description in the ETS

### Parameter "Artist name"

This parameter is for setting whether to display the artist name.

### Parameter "Album name"

This parameter is for setting whether to display the album name.

### Parameter "Play mode"

This parameter is for setting whether to enable play mode, display the parameters as follow when enable.

#### Output value for Play mode

- Parameter "Output value for single cycle/random play/playlist cycle/play in order"

This parameter is visible when 1byte is selected. Set the maximum volume value. Options:

0..255

#### Status feedback for Play mode

- Parameter "Status value for play in single cycle/random play/playlist cycle/play in order"

These parameters are for setting the status value for each play mode. Device will update the play mode displayed on the screen according to the feedback value. Options:

0..255

### 5.3.5 Parameter window "Colour and colour temperature control"

Parameter window "Colour and colour temperature control" as shown as Fig. 5.3.5.

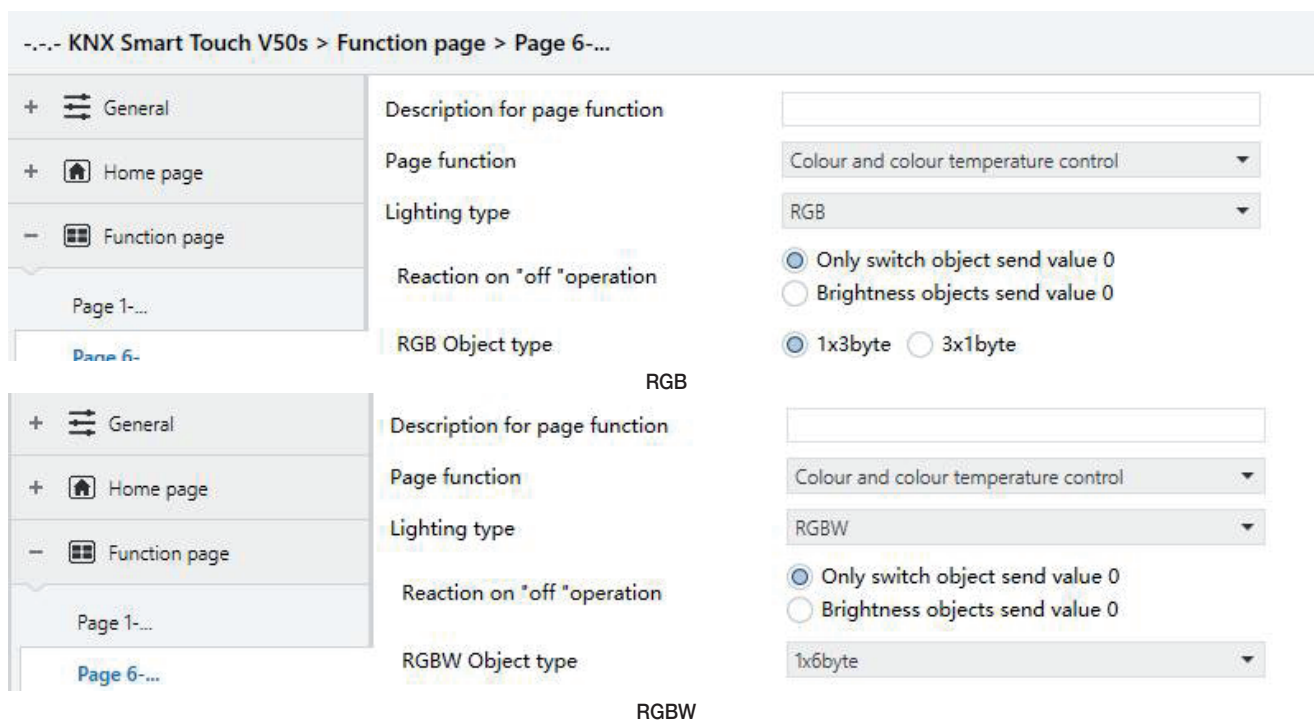



## Parameter setting description in the ETS

Fig. 5.3.5 "Colour and colour temperature control" parameter window

### Parameter "Lighting type"

This parameter is for setting the lighting type of RGB strip. Options:

- RGB
- RGBW
- RGBCW

RGB: suitable for adjusting RGB tricolour lamp;

RGBW: suitable for adjusting RGBW four colour lamp;

RGBCW: suitable for RGB tricolour lamp, brightness and color temperature control..

### Parameter "Reaction on "off "operation"

This parameter is for setting the sent telegram when "off" operation, you can choose only switch object send value 0, or the Brightness objects send value 0. Options:

- Only switch object send value 0
- Brightness objects send value 0

### Parameter "Colour temperature control type"

This parameter is for setting the control type of colour temperature. Options:

- Normal
- Directly(with warm/cool white algorithm)

Normal: send value of 1byte brightness and 2 byte colour temperature;

Directly(with warm/cool white algorithm): directly control, it has been built-in conversion algorithm for "Brightness + Colour Temperature" and Warm/cool white brightness, that is two 1byte objects, which is used for output brightness adjustment to control warm white LED and cool white LED.

### Parameter "RGB/RGBW Object type"

These parameters are for setting the object type of RGB or RGBW. Options:

Suitable for RGB type:

- 1x3byte
- 3x1byte

Suitable for RGBW type:

- 1x6byte
- 4x1byte
- 3byte+1byte

## Parameter setting description in the ETS

### Parameter “Status feedback object”

This parameter is visible when lighting type is RGBCW and the control type is “Directly(with warm/cool white algorithm)”. Set the status feedback object. Options:

- Brightness+Colour Temperature
- Warm/cool white brightness

Brightness+Colour Temperature: feedback of Brightness+Colour Temperature is to communicate accurately with the data from the other panel;

Warm/cool white brightness: feedback of Warm/cool white brightness is to communicate with actuator.

### Parameter “Min. colour temperature [2000..7000]°C”

- Parameter “Max. colour temperature [2000..7000]°C”

These parameters are visible when lighting type is RGBCW. Set the upper and lower limit threshold of colour temperature. Options:

2000..7000

### 5.3.6 Parameter window “Air Quality display”

Parameter window “Air Quality display” as shown as Fig. 5.3.6, for setting the function of air quality display, temperature, humidity, PM2.5, PM10, VOC, CO2, AQI, brightness, wind speed and rain status can be set to display. Up to 4 items can be displayed in one interface.

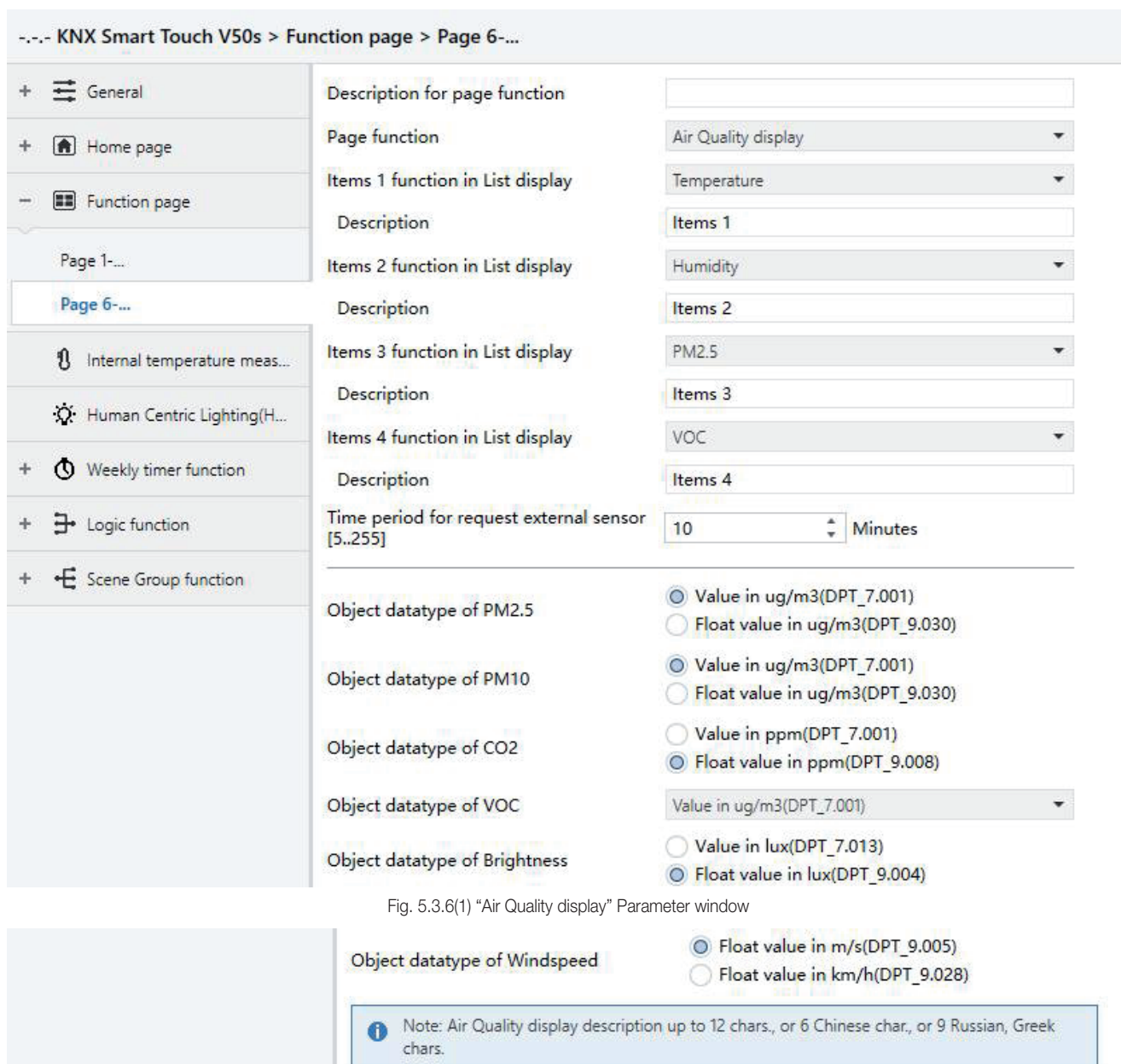

Fig. 5.3.6(1) “Air Quality display” Parameter window

Fig. 5.3.6(2) “Air Quality display” parameter window

## Parameter setting description in the ETS

### Parameter "Items x function in List display" (x=1~4)

Set the display in the list, up to 4 items can be displayed. Options:

**Disable**  
**Temperature**  
**Humidity**  
**PM2.5**  
**PM10**  
**CO2**  
**VOC**  
**AQI**  
**Brightness**  
**Wind speed**  
**Rain**

These values are detected by external sensors and passed to the screen for display. To enable the display, the screen will appear empty if the detected values are not received. Display range:

**Temperature: -40~99°C**  
**Humidity: 0~100%**  
**PM2.5: 0~999µg/m<sup>3</sup>**  
**PM10: 0~999µg/m<sup>3</sup>**  
**CO2: 0~4000ppm**  
**VOC: 0~9.99mg/m<sup>3</sup> or 0~4000ppm**  
**AQI: 0~500**  
**Brightness: 0~50000lux**  
**Wind speed: 0~50m/s or 0~183km/h**  
**Rain status: rain or no rain**

- **Parameter "Description"**

This parameter is for setting the description of air Quality display items, up to 18 characters can be input.

The actual display is up to 12 characters ( or 6 Chinese characters).

### Parameter "Time period for request external sensor [5..255]min"

This parameter is for setting the time period for read request external sensor. Options:

5..255

### Parameter "Object datatype of PM2.5"

This parameter is for setting the data type of PM2.5. Options:

**Value in µg/m<sup>3</sup>(DPT\_7.001)**  
**Float value in µg/m<sup>3</sup>(DPT\_9.030)**

### Parameter "Object datatype of PM10"

This parameter is for setting the data type of PM10. Options:

**Value in µg/m<sup>3</sup>(DPT\_7.001)**  
**Float value in µg/m<sup>3</sup>(DPT\_9.030)**

### Parameter "Object datatype of CO2"

This parameter is for setting the data type of CO2. Options:

**Value in ppm(DPT\_7.001)**  
**Float value in ppm(DPT\_9.008)**

## Parameter setting description in the ETS

---

### Parameter “Object datatype of VOC”

This parameter is for setting the data type of VOC. Options:

Value in  $\mu\text{g}/\text{m}^3$ (DPT\_7.001)

Float value in  $\mu\text{g}/\text{m}^3$ (DPT\_9.030)

Float value in ppm(DPT\_9.008)

### Parameter “Object datatype of Brightness”

This parameter is for setting the data type of brightness. Options:

Value in lux (DPT\_7.013)

Float value in lux (DPT\_9.004)

### Parameter “Object datatype of Windspeed”

This parameter is for setting the data type of wind speed. Options:

Float value in m/s (DPT\_9.005)

Float value in km/h (DPT\_9.028)

 Note: Air Quality display description up to 12 chars., or 6 Chinese char., or 9 Russian, Greek chars.

## Parameter setting description in the ETS

### 5.3.7 Parameter window “Floor heating”

Parameter window “Floor heating” as shown as Fig. 5.3.7, it is mainly for floor heating parameter setting.

--- KNX Smart Touch V50s > Function page > Page 6-...

General	Description for page function	
Home page	Page function	Floor heating
Function page	Work mode	Master
Page 1-...	Temperature reference from	Internal and External sensor combination
Page 6-...	Combination ratio	50% Internal to 50% External
Internal temperature meas...	Time period for request external sensor [0..255]	5 Minutes
Human Centric Lighting(H...	Read external sensor after restart	<input checked="" type="checkbox"/>
Weekly timer function	Send temperature when the result change by	1.0K
Logic function	Cyclically send temperature [0..255,0=inactive]	0 Minutes
Scene Group function	Control value after temp. error[0..100] (If 2-point control, set value '0'=0, set value '>0'=1)	0 %
	Power on/off status after download	<input type="radio"/> Off <input checked="" type="radio"/> On
	Power on/off status after voltage recovery	As before voltage failure
	Default set temperature[16..32]	20 °C
	Min. set temperature[16..32]	16 °C
	Max. set temperature[16..32]	32 °C
	Temperature control method	Heating on/off (2 point control)
	Object value of Heating on/off	<input checked="" type="radio"/> Heat on=1, Heat off=0 <input type="radio"/> Heat on=0, Heat off=1
	Lower Hysteresis[0..200]	20 *0.1K
	Upper Hysteresis[0..200]	20 *0.1K
	Cyclically send control value[0..255]	0 Minutes
	Scene function	<input type="checkbox"/>
	Timer function	<input type="checkbox"/>

Fig. 5.3.7 “Floor heating” parameter window

#### Parameter “Work mode”

This parameter is for setting the work mode of floor heating. Options:

- Single
- Master
- Slave

Single: floor heating function of the device is set to single control and with a temperature control algorithm, the output directly controls the actuator, when the device restarts, it sends the current status to the bus, such as power on/off, setpoint temperature;

Master: floor heating function of the device is set to multi-control and with a temperature control algorithm, the output is dominated by the device. When the device restarts, it sends the current status to the bus, such as power on/off, setpoint temperature;

Slave: floor heating function of the device is set to slave control, at this time it is only used as touch and display, no temperature control algorithm, when the device restarts, it will send the status read request, such as power on/off, setpoint temperature.

## Parameter setting description in the ETS

### Parameter “Temperature reference from”

This parameter is for setting the resource of floor heating temperature reference. Options:

- Internal sensor
- External sensor
- Internal and External sensor combination

Temperature setting of air conditioner is similar to RTC, detail please refer to section 5.3.2.

### Parameter “Power on/off status after download ”

When the work mode is “Slave”, this parameter is not visible.

Set the power on/off status of floor heating control interface after download. Options:

- Off
- On

### Parameter “Power on/off status after voltage recovery”

When the work mode is “Slave”, this parameter is not visible.

Set the power on/off status of floor heating control interface after device voltage recovery. Options:

- On
- Off
- As before voltage failure

On: the control interface is on when device is powered on, it is operational, floor heating will calculate internally according to the control type to determine the current heating status is on or off;

Off: the control interface is off when device is powered on, icons on the interface are not operational except for the icons of timer and on/off;

As before voltage failure: the control interface will recover to the status before voltage failure, if it is on, floor heating will calculate internally according to the control type to determine the current controlling status.

### Parameter “Default set temperature [16..32]°C”

When the work mode is “Slave”, this parameter is not visible.

Set the default set temperature when floor heating is on. Options:

- 16°C
- 17°C
- ...
- 32°C

When the default setpoint temperature is less than the min. setpoint temperature, display following warning:

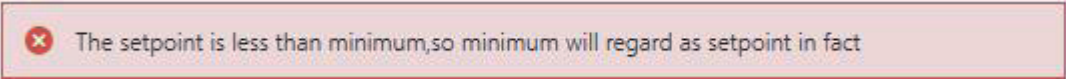

✘ The setpoint is less than minimum,so minimum will regard as setpoint in fact

When the default setpoint temperature is greater than the max. setpoint temperature, display following warning:

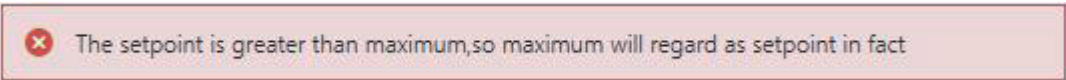

✘ The setpoint is greater than maximum,so maximum will regard as setpoint in fact

### Parameter “Min./Max. set temperature [16..32]°C”

These parameters are for setting the adjustable range of the setpoint temperature, the minimum value should be less than the maximum value, if the setting temperature beyond the limited range, it will output the limited temperature. (Note: if the min. temperature is greater than or equal to the max., default rang is 16~32°C.) Options:

- 16°C
- 17°C
- ...
- 32°C

For setpoint temperature, the Min. value must less than the Max., if not, it can not be configured on ETS.

## Parameter setting description in the ETS

### Parameter "Temperature control method"

When the work mode is "Slave", this parameter is not visible.

Set the temperature control method of floor heating. Different control types are suitable for controlling different temperature controllers. Options:

**Heating on/off (use 2-point control)**

**Heating PWM (use PI control)**

**Heating continuous control (use PI control)**

**These parameters as follow are visible when "Heating on/off (use 2-point control)" is selected:**

Under 2-point control, when the temperature is higher than a certain setting temperature, heating off, below a certain setting temperature, heating on.

- **Parameter "Object value of Heating on/off"**

Define the triggered value of floor heating on/off. Options:

**Heat on=1, Heat off=0**

**Heat on=0, Heat off=1**

- **Parameter "Lower Hysteresis [0..200]\*0.1K"**

- **Parameter "Upper Hysteresis [0..200]\*0.1K"**

These two parameters are for setting the lower/upper hysteresis setpoint temperature of floor heating. Options:

**0..200**

**When the actual temperature (T) > the setting temperature + the upper hysteresis temperature, then will stop heating;**

**When the actual temperature (T) < the setting temperature - the lower hysteresis temperature, then will start heating.**

For example, the lower hysteresis temperature is 1K, the upper hysteresis temperature is 2K, the setting temperature is 16°C, if T is higher than 18°C, then it will stop heating; if T is lower than 15°C, then it will start heating; if T is between 15-18°C, then it will maintain the previous status.

**These parameters as follow are visible when "Heating PWM (use PI control)" and "Heating continuous control (use PI control)" are selected:**

When in Heating PWM (use PI control), floor heating will in cyclically switch control to the valve according to the controlling value.

When in Heating continuous control (use PI control), floor heating will control the opening/closing status of the valve according to the controlling value.

- **Parameter "Invert control value"**

Set the control object to send the control value normally, or send the inverted control value, so that the control value can adapt to the type of valve.

When enabled, it is sent to the bus through the object after the control value is reversed.

- **Parameter "PWM cycle time [1..255] min"**

This parameter is only visible when the control type is "Heating PWM (use PI control)". For setting the period of the control object cycle to send the switch value, the object sends the switch value according to the duty cycle of the control value. For example, if the set period is 10 min and the control value is 80%, then the object will send an on telegram for 8 min and an off telegram for 2 min. If the control value is changed, the time duty ratio of the on/ off telegram of the object will also change, but the period is still the time of parameter setting. Options:

**1..255**

- **Parameter "Heating speed"**

Set the response speed of the heating PI controller. Different response speeds apply to different environments. Options:

**Hot water heating (5°C/150min)**

**Underfloor heating (5°C/240 min)**

**Electrical heating (4°C/100min)**

**User defined**

- **Parameter "Proportional range[10..100]\*0.1°C"(P value)**

- **Parameter "Reset time [0..255]min" (I value)**

This parameter is visible when the parameter "Heating speed" is selected "User defined", used to set the PI value of the PI controller.

**More descriptions of two-point control mode and PI control mode refer to section 5.3.2.**

- **Parameter "Cyclically send control value [0..255]min"**

This parameter is for setting the period for cyclically sending the control value to the bus. Options:

**0..255**

### Parameter "Scene function"

When the work mode is "Slave", this parameter is not visible. Set whether to enable scene function. When enabled, link to power on/off, mode, setpoint temperature.



## Parameter setting description in the ETS

### Parameter "Timer function"

When the work mode is "Slave", this parameter is not visible. Set whether to enable timer function.

#### 5.3.7.1 Parameter window "Scene"

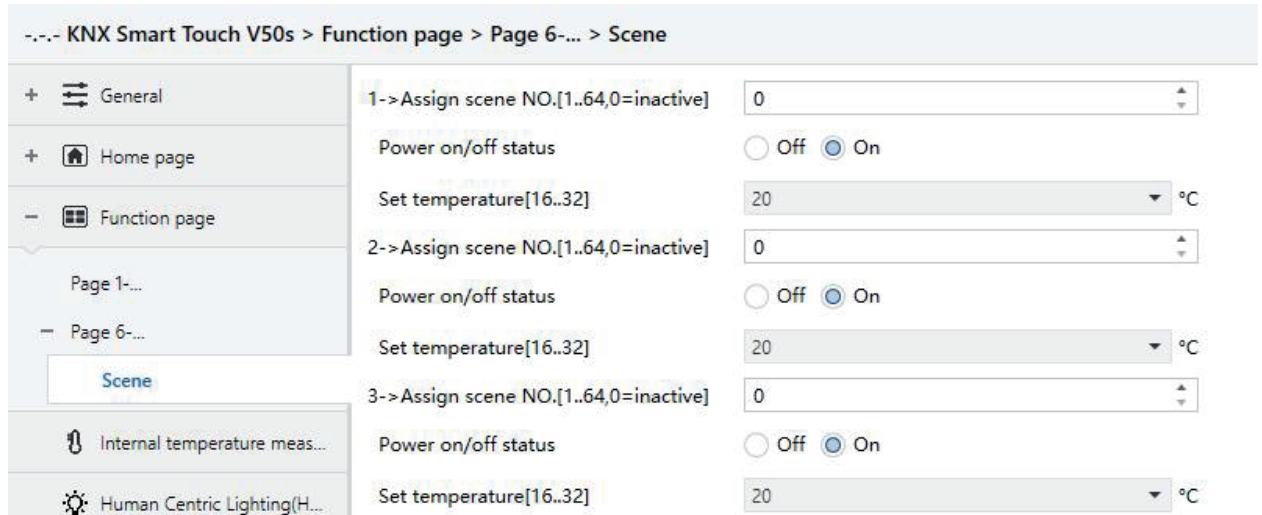

Fig. 5.3.7.1 "Scene" parameter window

When the work mode is "Slave", this parameter window is not visible. This parameter window is visible when scene function is enabled.

### Parameter "x->Assign scene NO. [1..64,0=inactive]" (x=1-5)

This parameter is for setting the triggered scene number. Up to support 5 triggered scenes. Options:

**0..64, 0=inactive**

Scenes can be recalled or stored. When a new scene is stored, the original saved new scene is still valid when the voltage is recovered again after the bus has been powered down.

### Parameter "ON/OFF"

This parameter is for setting status of On/Off. Options:

Off

On

This parameter as follow is not visible when Off is selected:

### Parameter "Set temperature [16..32]°C"

This parameter is for setting the status of setpoint temperature. Options:

16°C

17°C

...

32°C

When the setpoint temperature is less than the min. set temperature, display following warning:

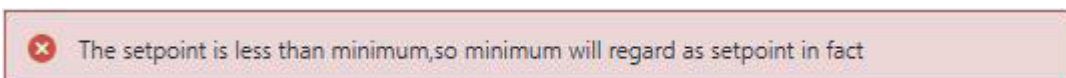

When the setpoint temperature is greater than the max. set temperature, display following warning:

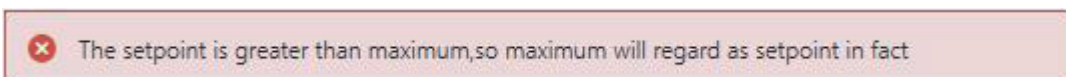



## Parameter setting description in the ETS

### 5.3.8 Parameter window “Ventilation System”

Parameter window “Ventilation System” as shown as Fig. 5.3.8, for ventilation system parameter setting.

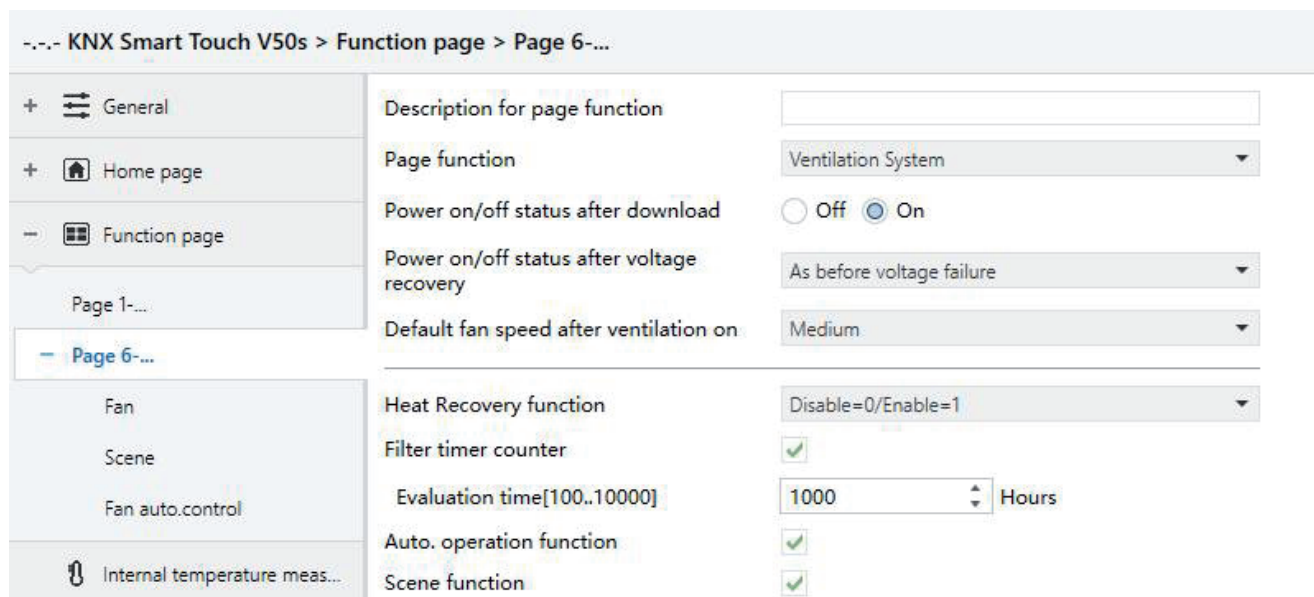

-.- KNX Smart Touch V50s > Function page > Page 6-...		
+ [Menu] General	Description for page function	<input type="text"/>
+ [Home] Home page	Page function	Ventilation System
- [Grid] Function page	Power on/off status after download	<input type="radio"/> Off <input checked="" type="radio"/> On
Page 1-...	Power on/off status after voltage recovery	As before voltage failure
- Page 6-...	Default fan speed after ventilation on	Medium
Fan	Heat Recovery function	Disable=0/Enable=1
Scene	Filter timer counter	<input checked="" type="checkbox"/>
Fan auto.control	Evaluation time[100..10000]	1000 Hours
[Lock] Internal temperature meas...	Auto. operation function	<input checked="" type="checkbox"/>
	Scene function	<input checked="" type="checkbox"/>

Fig. 5.3.8 “Ventilation system” parameter window

#### Parameter “Power on/off status after download”

This parameter is for setting the power on/off status of the ventilation system interface after the application is downloaded. Options:

- Off
- On

#### Parameter “Power on/off status after voltage recovery”

This parameter is for setting the power on/off status of ventilation system interface after device voltage recovery. Options:

- On
- Off
- As before voltage failure

On: device will power off when voltage recovery, this interface can not be operated, except for filter reset and power ON/OFF;

Off: device will power off when voltage recovery, this interface can not be operated, except for filter reset and power ON/OFF;

As before voltage failure: device will return to the power status as before voltage failure when voltage recovery.

#### Parameter “Default fan speed after ventilation on”

This parameter is for setting the initial fan speed after ventilation on. Options:

- Low
- Medium
- High

#### Parameter “Heat Recovery function”

This parameter is for setting whether to enable heat recovery function of ventilation. Options:

- Disable
- Disable=0/Enable=1
- Disable=1/Enable=0

If the latter two options are selected, the heat recovery of ventilation defaults to be enabled, that is, enabled once power on.

When disabled, it is uncontrollable.

## Parameter setting description in the ETS

### Parameter “Filter timer counter”

This parameter is for setting whether to enable filter timer counter function.

When enable, the following parameter is visible.

- Parameter “Evaluation time [100..10000]h”

This parameter is for setting the service life of the filter. Options: 100..10000

If the filter takes longer than the setting time, the filter will send an alarm and prompt to clean the filter.

The life length of the filter can be reset through the object “Filter timer reset”.

The life length of the filter can be counted by the object “Filter timer counter”. The counting duration is in hours. The counting value will be sent to the bus when it has changed, and the counting duration of filter can be modified through the bus.

### Parameter “Auto. operation function”

This parameter is for setting whether to enable the interface of auto. fan speed operation is visible. When enabled, the fan speed is lined to the detection of PM2.5 or CO2, which is obtained from the bus. Telegram of auto. fan speed is that value 1 is activated, value 0 is cancel.

### Parameter “Scene function”

This parameter is for setting whether to enable scene function of ventilation.

#### 5.3.8.1 Parameter window “Fan”

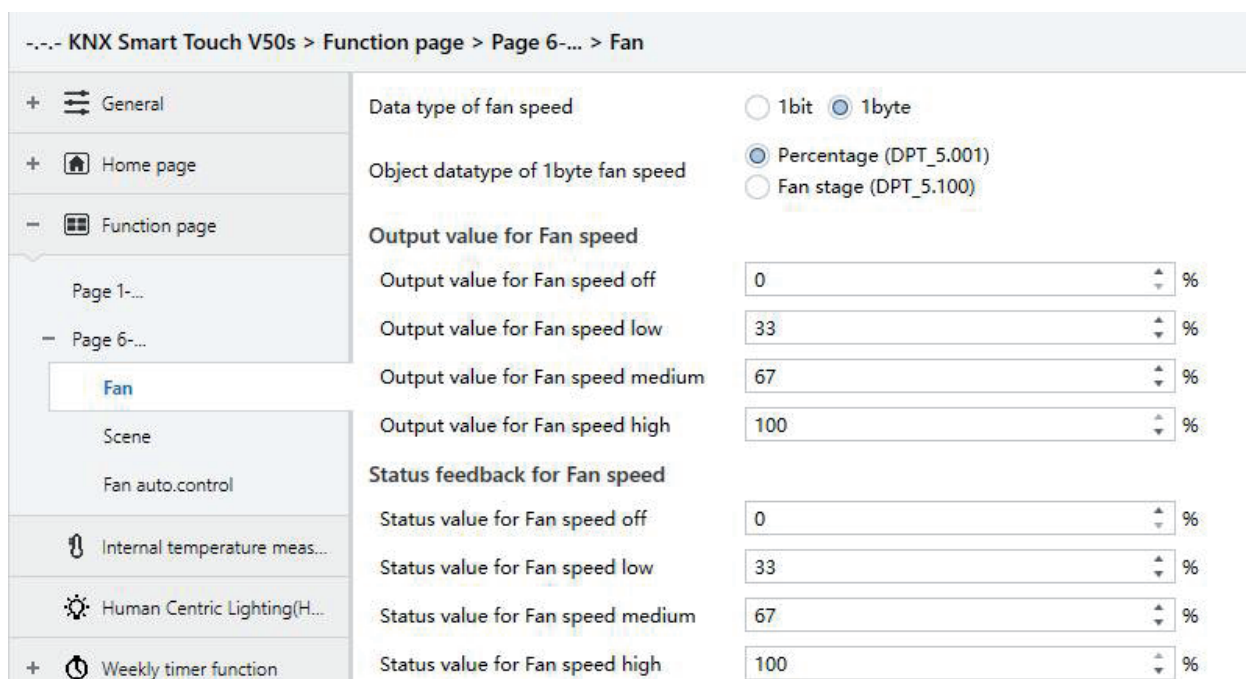

Fig. 5.3.8.1 “Fan” parameter window

## Parameter setting description in the ETS

### Parameter "Data type of fan speed"

This parameter is for setting the object datatype of fan speed. Options:

- 1bit
- 1byte

Parameters as follow are visible when 1bit is selected:

- Parameter "Object value for Fan speed off/low/medium/high"

These parameters define the sending value for each fan speed switchover, they are sent by three 1bit objects at the same time. Options:

- No.1=0, No.2=0, No.3=0
- No.1=1, No.2=0, No.3=0
- No.1=0, No.2=1, No.3=0
- No.1=1, No.2=1, No.3=0
- No.1=0, No.2=0, No.3=1
- No.1=1, No.2=0, No.3=1
- No.1=0, No.2=1, No.3=1
- No.1=1, No.2=1, No.3=1

Parameters as follow are visible when 1nyte is selected:

- Parameter "Object datatype of 1byte fan speed"

This parameter is for setting the object datatype of 1byte fan speed. Options:

- Fan stage (DPT 5.100)
- Percentage (DPT 5.001)

Output value for Fan speed

- Parameter "Output value for Fan speed off/low/medium/high"

These parameters are for setting the output value for each fan speed switchover. Options according to fan object datatype:

- 0..255/0..100

Status feedback for Fan speed

- Parameter "Status value for Fan speed off/low/medium/high"

These parameters are for setting the status feedback value for each fan speed. Device will be updated display according to the feedback value. Options according to fan object datatype:

- 0..255/0..100

*Note: the out value and status value must meet the condition off<low<medium<high, if not, they can not be configured on ETS, and display red box warning, as shown as follow:*

Output value for Fan speed off	<input type="text" value="0"/>	%
Output value for Fan speed low	<input style="border: 2px solid red;" type="text" value="68"/>	%
Output value for Fan speed medium	<input type="text" value="67"/>	%
Output value for Fan speed high	<input type="text" value="100"/>	%

### Parameter "Delay between fan speed switch [0..100]\*50ms"

This parameter defines the conversion delay time, and it can be considered according to the technical characteristics of the fan. Options:

- 0...100

When switch fan speed, first should turn off fan speed, then turn on fan speed after delay time before the telegram can be sent to the bus. When the delay time is set to 0, it will not be turned off first, but will switch directly to the next fan speed.

## Parameter setting description in the ETS

### 5.3.8.2 Parameter window “Scene”

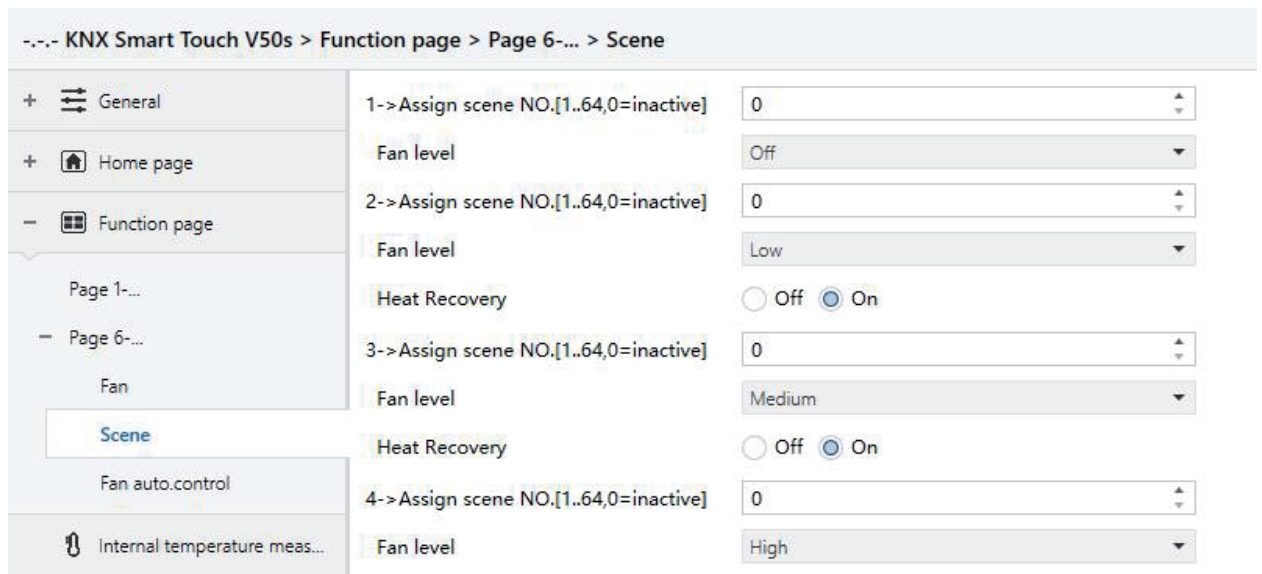

Fig.5.3.8.2(1) “Scene” parameter window

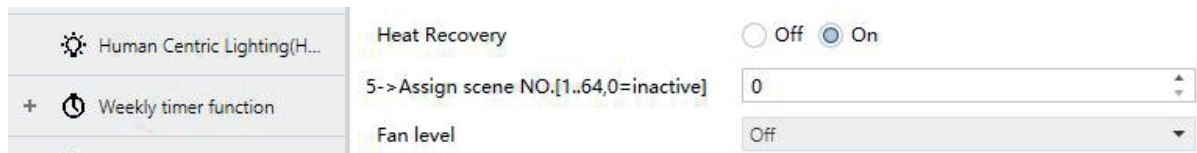

Fig. 5.3.8.2(2) “Scene” parameter window

This parameter window is visible when scene function is enabled.

#### Parameter “x->Assign scene NO. [1..64,0=inactive]” (x=1-5)

This parameter is for setting the triggered scene number. Up to support 5 triggered scenes. Options:

0..64, 0=inactive

- **Parameter “Fan level”**

This parameter is for setting fan speed level of scene x. Options:

Off

Low

Medium

High

This parameter as follow is not visible when Off is selected.

- **Parameter “Heat Recovery”**

This parameter is visible when heat recovery function is enabled. Setting the heat recovery status of scene of scene x. Options:

Off

On

Parameter setting description in the ETS

5.3.8.3 Parameter window “Fan auto.control”

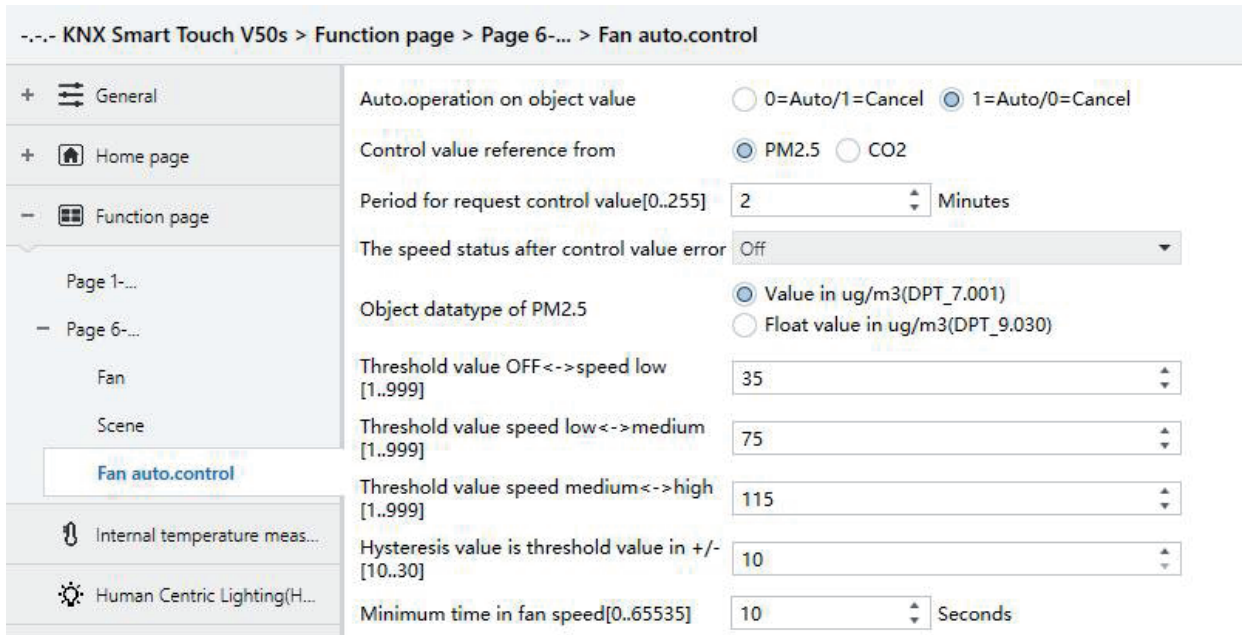

Fig. 5.3.8.3(1) “Auto. Control\_PM2.5”Parameter window

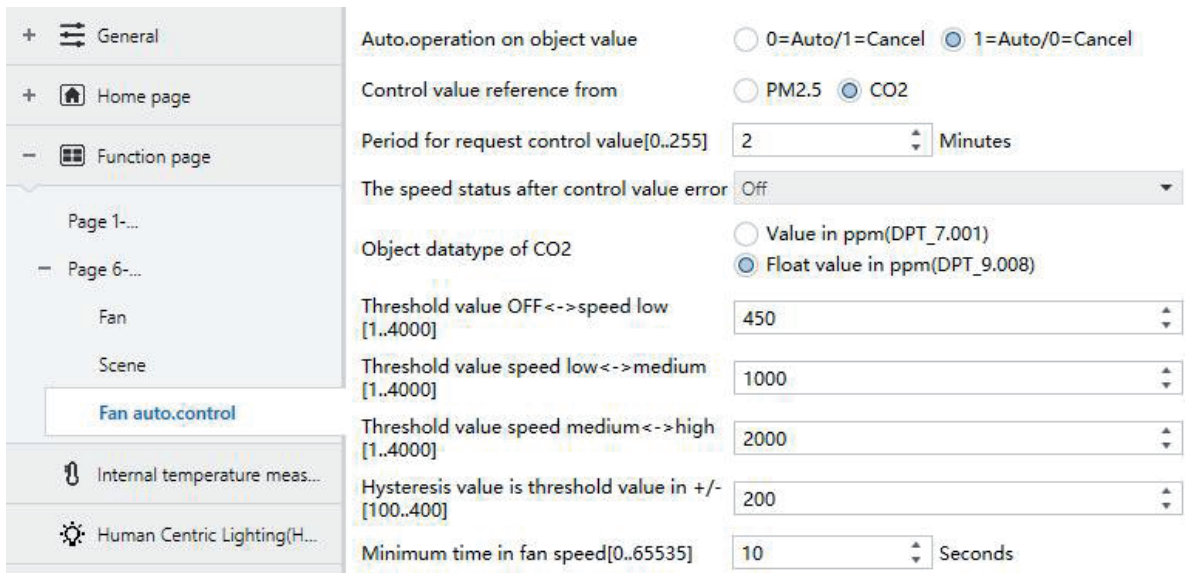

Fig. 5.3.8.3(2) “Auto. Control\_CO2” parameter window

After automatic operation is activated, ventilation system will automatically adjust fan speed according to the control value. This parameter window is visible when automatic operation function is enabled.

**Parameter “Auto. operation on object value”**

This parameter is for setting the telegram value to activate automatic operation. Options:

**0=Auto/1=Cancel**

**1=Auto/0=Cancel**

0=Auto/1=Cancel: when the object “Automatic function” receives the telegram value “0”, activate the automatic operation, when receive “1”, exit the automatic operation;

1=Auto/0=Cancel: when the object “Automatic function” receives the telegram value “1”, activate the automatic operation, when receive “0”, exit the automatic operation.

After power-on, automatic operation is not activated by default.

**Parameter “Control value reference from”**

This parameter is for setting the reference of control value under automatic operation. Options:

**PM2.5**

**CO2**

## Parameter setting description in the ETS

### Parameter "Period for request control value [0..255] Min"

This parameter is for setting the time period for device to send a control value read request to external sensor. Options:

0..255

### Parameter "The speed status when the control value error"

This parameter is for setting the default fan speed of ventilation system when control value is error. Options:

Off

Low

Medium

High

**Note:** when reading the control value from external sensor, if there is no response, then it will be considered as external sensor failure and control value error by default.

### Parameter "Object datatype of PM2.5"

This parameter is for setting the datatype of PM2.5. Datatype determines object type, select it according to the docking PM2.5 sensor data type. Options:

Value in  $\mu\text{g}/\text{m}^3$ (DPT\_7.001)

Float value in  $\mu\text{g}/\text{m}^3$ (DPT\_9.030)

DPT\_7.001: suitable for integrated value.

DPT\_9.030: suitable for float value.

### Parameter "Object datatype of CO2"

This parameter is for setting the datatype of CO2. Datatype determines object type, select it according to the docking CO2 sensor data type. Options:

Value in ppm(DPT\_7.001)

Float value in ppm(DPT\_9.008)

DPT\_7.001: suitable for integrated value.

DPT\_9.008: suitable for float value.

### Parameter "Threshold value OFF<-->speed Low [1..999]/ [1...4000]"

Define threshold value for speed OFF<-->low, options:

1..999/1..4000

If the control value is greater than or equal to this setting threshold value, start to run low fan speed; if the control value is less than this setting threshold value, the fan will be turned off.

### Parameter "Threshold value speed low<-->medium [1..999]/ [1...4000]"

Define the threshold value for speed low<-->medium, if the control value is greater than or equal to this setting threshold, start to run medium fan speed. Options:

1..999/1..4000

### Parameter "Threshold value speed medium<-->high[1..999]/ [1...4000]"

Define the threshold for speed medium<-->high, if the control value is greater than or equal to this setting threshold, start to run high fan speed. Options:

1..999/1..4000

**Tip:** The controller evaluates the threshold in ascending order.

First check →OFF <-> low fan speed threshold →low fan speed <-> medium fan speed →medium fan speed <-> high fan speed.

The correctness of functional execution is guaranteed only in this case:

The threshold of OFF <-> low fan speed is lower than that of low fan speed <-> medium fan speed, and the threshold of low fan speed <-> medium fan speed is lower than that of medium fan speed <-> high fan speed.

Parameter setting description in the ETS

Parameter "Hysteresis value is threshold value in +/- [10...30]/[100..400]"

This parameter is for setting the hysteresis value of the threshold value, which can avoid the unnecessary action of the fan when the control value fluctuates near the threshold. Options: 10..30/100..400

For example, the control type is PM2.5, the Hysteresis value is 10 and the threshold is 35, then the upper limit threshold 45 (Threshold value+Hysteresis value) and the lower limit threshold 25 (Threshold value-Hysteresis value). When the control value is between 25-45, fan action will not be caused, and the previous status will still be maintained. Only less than 25 or greater than or equal to 45 will change the running status of the fan. As shown in the following figure:

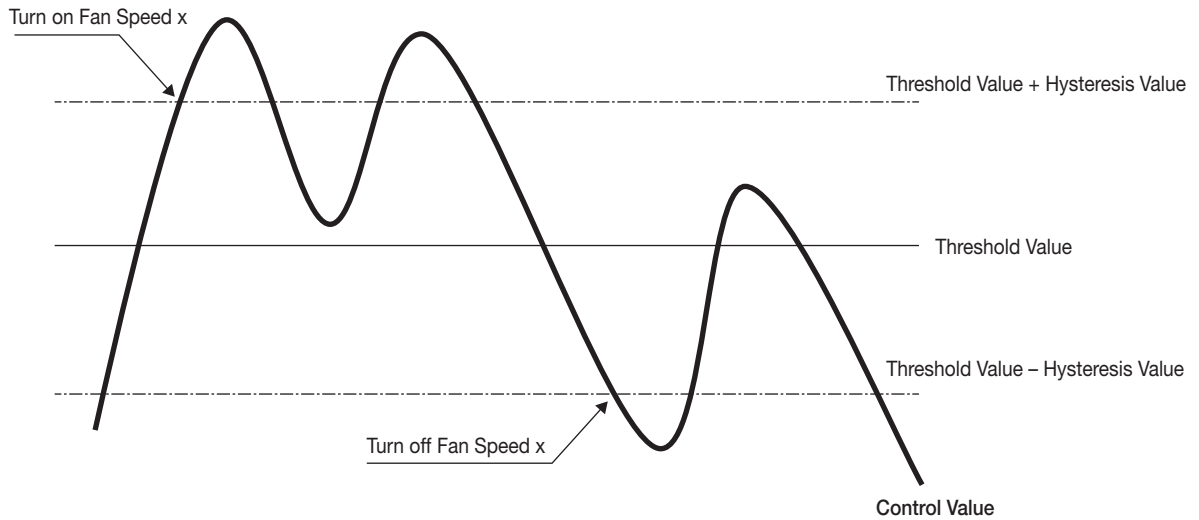

Note:

When hysteresis is enabled, if the threshold overlap occurs, fan action is specified as follows:

- 1) Hysteresis determines the control point where Fan speed conversion occurs;
- 2) If Fan speed conversion occurs, new fan speed is determined by control value and threshold value, irrespective of hysteresis.

For example (1):

Take PM2.5 as an example

OFF <-> Low fan speed threshold value is 35

Low fan speed <-> Medium fan speed threshold value is 55

Medium fan speed <-> High fan speed threshold value is 75

Hysteresis value is 25

The fan speed of the fan turbine increases from OFF:

Fan OFF status will change at a control value of 60 ( $\geq 25+35$ ), and new fan speed will be the mid-fan speed (because 60 is between 55 and 75, irrespective of hysteresis at this time), so the low fan speed is ignored;

The behavior of fan speed when descending from a high fan speed:

The high fan speed will change at a control value of 50 ( $< 75-25$ ), and new fan speed will be low fan speed (because 50 is between 35 and 55, irrespective of hysteresis), so the fan speed is ignored.

For example(2):

Take PM2.5 as an example

OFF <-> Low fan speed threshold value is 20

Low fan speed <-> Medium fan speed threshold value is 40

Medium fan speed <-> High fan speed threshold value is 70

Hysteresis value is 10

When fan speed is increasing from OFF:

The OFF status will be turned when the control value is 30 ( $\geq 20+10$ )

When the control value 41 is received, the new speed will be at medium(because the hysteresis is ignored when the value 41 is between 40 and 70), therefore the low speed is ignored.

When the control value 39 is received, the new speed will be at low (because the hysteresis is ignored when the value 39 is between 20 and 40)

When Fan Speed decreasing from high:

The high speed will be turned when the control value is 60 ( $< 70-10$ )

When the control value 39 is received, the new speed will be at low(because the hysteresis is ignored when the value 39 is between 20 and 40),therefore the medium speed is ignored.

- 3) When the control value is 0,the fan will be off at any circumstances.



## Parameter setting description in the ETS

### Parameter "Minimum time in fan speed [0...65535]s"

Defines the residence time of the fan from the current fan speed to a higher fan speed or lower fan speed, that is, the minimum time for a fan speed operation.

If you need to switch to another fan speed, you need to wait for this period of time before switching.

If the current fan speed has been running long enough, the fan speed can be changed quickly.

Options:

0..65535

0: there is no minimum running time, but the delay switching time of fan speed still needs to be considered.

**Note:** The residence time for this parameter setting is only enabled in Auto mode.

### 5.3.9 Parameter window "Energy Metering display"

Parameter window "Energy Metering display" as shown as Fig. 5.3.9, for setting the function of energy metering display, current, voltage, power and energy can be set to display. Up to 8 items can be set to display in the interface.

--- KNX Smart Touch V50s > Function page > Page 6-...

+  General	Description for page function	<input type="text"/>
+  Home page	Page function	Energy Metering display
-  Function page	Number of Energy metering	4
Page 1-...	<b>Energy Meter 1</b>	
<b>Page 6-...</b>	Description	Energy Meter 1
Internal temperature meas...	Data type of display value	Value in mA (DPT 7.012)
Human Centric Lighting(H...	<b>Energy Meter 2</b>	
+  Weekly timer function	Description	Energy Meter 2
+  Logic function	Data type of display value	Value in mA (DPT 7.012)
+  Scene Group function	<b>Energy Meter 3</b>	
	Description	Energy Meter 3
	Data type of display value	Value in mA (DPT 7.012)
	<b>Energy Meter 4</b>	
	Description	Energy Meter 4
	Data type of display value	Value in mA (DPT 7.012)
	Time period for request meter value [5..255]	10 Minutes
<p><b>i</b> Note: Energy Meter description up to 12 chars., or 6 Chinese chars., or 9 Russian, Greek chars.</p>		

Fig. 5.3.9 "Energy Metering display" parameter window



## Parameter setting description in the ETS

### Parameter “Number of Energy metering”

Set for the number of energy metering in the energy metering display interface. Options:

1/2/3/4/5/6/7/8

Up to 8 items can be set to display.

#### Energy Meter x (x=1..8)

- Parameter “Description”

This parameter is for setting the description of energy display items. Up to 18 characters can be input and up to 6 Chinese characters can be displayed.

- Parameter “Data type of display value”

This parameter is for setting the data type of energy metering display items. Options:

- Value in mA(DPT 7.012)
- Float value in mA(DPT 9.021)
- Float value in A(DPT 14.019)
- Float value in mV(DPT 9.020)
- Float value in V(DPT 14.027)
- Float value in W(DPT 14.056)
- Float value in kW(DPT 9.024)
- Value in Wh(DPT 13.010)
- Value in kWh(DPT 13.013)

### Parameter “Time period for request meter value[5..255]Min”

This parameter is for setting the time period for the request meter value of the device sent to external metering actuator. Options

5...255

**i** Note: Energy Meter description up to 12 chars., or 6 Chinese chars., or 9 Russian, Greek chars.

### 5.4 Parameter window “Internal temperature measurement”

Parameter window “Internal temperature measurement” as shown as Fig. 5.4. It is mainly for setting related parameters of internal sensor detection.

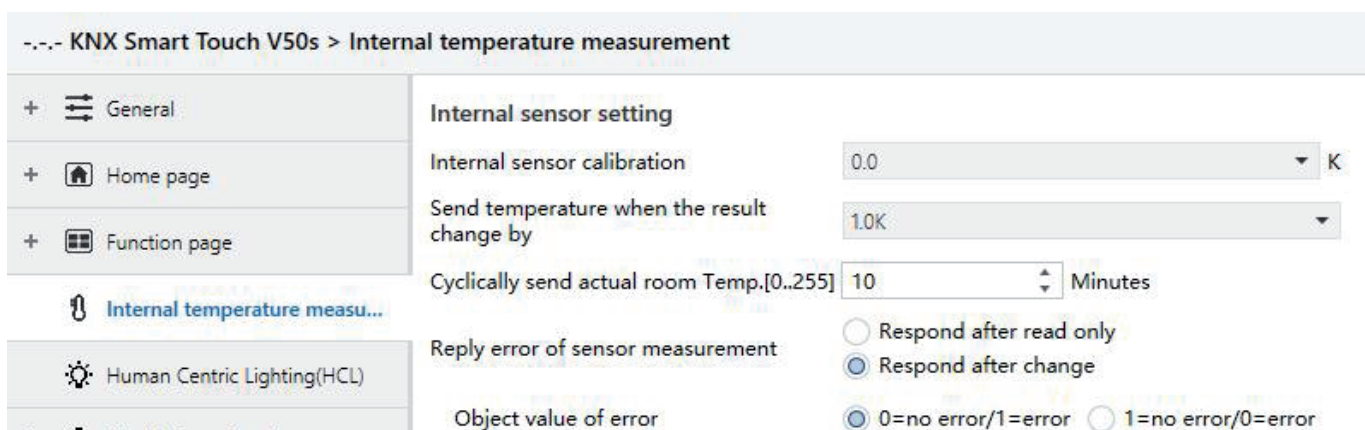

Fig. 5.4 “Internal temperature measurement” parameter window

The following parameters is used for setting the calibration value, sending condition and error report of internal sensor. If internal sensor is selected for other functions as well, please refer to this section.

## Parameter setting description in the ETS

### Parameter “Internal sensor calibration”

This parameter is for setting the temperature calibration value of the internal sensor, that is, to calibrate the measured value of internal sensor to make it closer to the current ambient temperature. Options:

-5.0K  
...  
0.0K  
...  
5.0K

**Note:** after the device is powered on, the stability time of internal sensor detection will take 30 minutes, therefore, the detected temperature value in the early stage of device work may be inaccurate.

### Parameter “Send temperature when the result change by”

This parameter is for setting when temperature turns to a certain value, whether to enable to send the current temperature value to the bus. Not send when disable. Options:

Disable  
0.5K  
...  
10.0K

### Parameter “Cyclically send actual room Temp.[0..255]min”

Set the time for cyclically sending the temperature detection value to the bus. Options: 0..255

This period is independent and starts time counting after programming completion or reset. Transmission change has no affect on this period.

### Parameter “Reply error of sensor measurement”

This parameter is for setting the condition of sending error status report when internal sensor error, options:

**Respond after read only**  
**Respond after change**

Respond after read only: only when the device receives a read error from other bus device or bus will the object “Temp.error report” send the error status to the bus;

Respond after change: the object “Temp.error report” will immediately send the telegram to the bus to report the error value when the error status has changed.

#### • Parameter “Object value of error”

This parameter is for defining object value of error. Options:

**0=no error/1=error**  
**1=no error/0=error**

0=no error/1=error: the object value for which internal sensor no error occurs is 0, and the object value for which internal sensor error occurs is 1;

1=no error/0=error: it has the opposite meaning.

**Note:** if the internal sensor connection is abnormal or the detected temperature is outside the range of -20°C ~ 60°C, the device will consider the sensor as faulty or wrong.

## Parameter setting description in the ETS

### 5.5 Parameter window “Human Centric Lighting (HCL)”

Parameter window “Human Centric Lighting(HCL)” as shown as Fig. 5.5(1), Fig. 5.5(2). It is mainly for setting related parameters of brightness and colour temperature.

--- KNX Smart Touch V50s > Human Centric Lighting(HCL)

+  General	Switching time	<input type="radio"/> Depend to certain time <input type="radio"/> Depend to sunrise&sunset
+  Home page	HCL behavior after voltage recovery	Stop running
+  Function page	HCL behavior at receiving switch control telegram "Off"	<input checked="" type="radio"/> Ignore, and keep running <input type="radio"/> Stop running
Internal temperature meas...	HCL behavior at receiving other control telegram from bus	Ignore, and keep running
Human Centric Lighting(...)	Colour temperature control type	<input checked="" type="radio"/> Normal <input type="radio"/> Directly(with warm/cool white algorithm)
+  Weekly timer function	Control brightness via HCL	<input type="radio"/> Disable <input checked="" type="radio"/> Enable
+  Logic function	Time 1	<input checked="" type="checkbox"/>
+  Scene Group function	Time	06:00
	Colour temperature preset	2700 K
	Brightness preset	50 %
	Time 2	<input checked="" type="checkbox"/>
	Time	08:00
	Colour temperature preset	4000 K
	Brightness preset	100 %

Fig. 5.5(1) “Human Centric Lighting(HCL)-Depend to certain time” parameter window

+  General	Switching time	<input type="radio"/> Depend to certain time <input checked="" type="radio"/> Depend to sunrise&sunset
+  Home page	HCL behavior after voltage recovery	Stop running
+  Function page	HCL behavior at receiving switch control telegram "Off"	<input checked="" type="radio"/> Ignore, and keep running <input type="radio"/> Stop running
Internal temperature meas...	HCL behavior at receiving other control telegram from bus	Ignore, and keep running
Human Centric Lighting(...)	Colour temperature control type	<input checked="" type="radio"/> Normal <input type="radio"/> Directly(with warm/cool white algorithm)
+  Weekly timer function	Control brightness via HCL	<input type="radio"/> Disable <input checked="" type="radio"/> Enable
+  Logic function	Time 1	<input checked="" type="checkbox"/>
+  Scene Group function	Time	Sunrise +-0min
	Colour temperature preset	2700 K
	Brightness preset	50 %
	Time 2	<input checked="" type="checkbox"/>
	Time	Sunrise +2h
	Colour temperature preset	4000 K
	Brightness preset	100 %

Fig. 5.5(2) “Human Centric Lighting(HCL)-Depend to sunrise&sunset” parameter window

## Parameter setting description in the ETS

### Parameter “Switching time”

This parameter is for setting the method of switching time. Options:

- Depend to certain time
- Depend to sunrise&sunset

### Parameter “HCL behavior after voltage recovery”

This parameter is for setting running behavior of HCL after voltage recovery. Options:

- Start running
- Stop running
- As before voltage failure

### Parameter “HCL behavior at receiving switch control telegram “Off””

This parameter is for setting running behavior of HCL when receiving switch control telegram “Off”. Options:

- Ignore, and keep running
- Stop running

Ignore, and keep running: ignore the receiving telegram and keep running HCL, no display the object “Switch control”;  
Stop running: stop running HCL.

### Parameter “HCL behavior at receiving other control telegram from bus”

This parameter is for setting running behavior of HCL when receiving other control telegram from bus. Options:

- Ignore, and keep running
- Ignore, but stop running
- Update preset value, and keep running
- Update preset value, and stop running

Ignore, and keep running: ignore the receiving telegram and keep running HCL;

Ignore, but stop running: ignore the receiving telegram but stop running HCL;

Update preset value, and keep running: update the current brightness or colour temperature when receiving their telegrams, and keep running HCL;

Update preset value, and stop running: update the current brightness or colour temperature when receiving their telegrams, but stop running HCL.

**Note: telegrams received during that time period, update the parameter presets for that time period.**

**In the HCL stops running, it is not logged. Updated presets will be saved when voltage failure.**

### Parameter “Colour temperature control type”

This parameter is for setting the control type of colour temperature. Options:

- Normal
- Directly (with warm/cool white algorithm)

Normal: send value of 1byte brightness and 2 byte colour temperature;

Directly(with warm/cool white algorithm): directly control, it has been built-in conversion algorithm for “Brightness + Colour Temperature” and Warm/cool white brightness, that is two 1byte objects, which is used for output brightness adjustment to control warm white LED and cool white LED.

### Parameter “Control brightness via HCL”

This parameter is visible when previous parameter is selected “Normal”. Set whether to control brightness via HCL.

Parameters as follow are used to preset the brightness and colour temperature for each time period, up to set 10 time periods:

Time x (x=1~10)

### Parameter “Time x” (x=1~10)

This parameter is for setting whether to enable time x.

When enabled, three parameter as follow are visible.

## Parameter setting description in the ETS

### Parameter "Time"

This parameter is for setting the preset time period, options are different according to the method of switching time.

When "Depend to certain time" is selected, options:

00:00  
01:00  
02:00  
...  
23:00

When "Depend to sunrise&sunset" is selected, options:

Sunrise -5h	Sunset +-0min
Sunrise -4h	Sunset +30min
...	Sunset +1h
Sunrise -1h	...
Sunrise -30min	Sunset +4h
Sunrise +-0min	Sunset +5h
...	

### Parameter "Colour temperature preset"

This parameter is for setting the preset colour temperature. Options:

2000..7000K

### Parameter "Brightness preset"

This parameter is visible when control type of colour temperature is selected "Normal" and the parameter "Control brightness via HCL" is enabled, or the type is selected "Directly(with warm/cool white algorithm)". Set the preset brightness. Options:

0%  
5%  
10%  
...  
95%  
100%

## 5.6 Parameter window "Weekly timer function"

Parameter window "Weekly timer function" as shown as Fig. 5.6, up to 16 time functions can be configured.

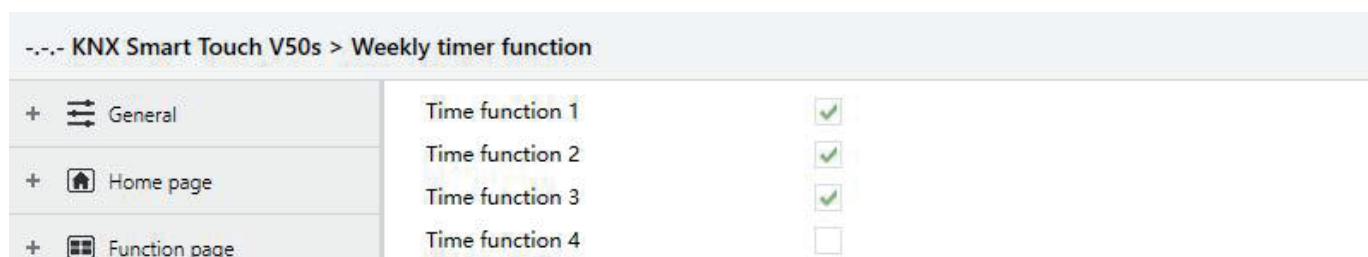

Fig. 5.6 "Weekly timer function" parameter window

### Parameter "Time function x" (x=1~16)

This parameter is for setting whether to enable time function x. Corresponding parameter window and objects are visible when enabled.

## Parameter setting description in the ETS

### 5.6.1 Parameter window “Time x”

Parameter window “Time x” as shown as Fig. 5.6.1, for setting the value and timing time sent by each timer Parameters of each time function are the same. Take a timer setting for example to introduce their parameter settings.

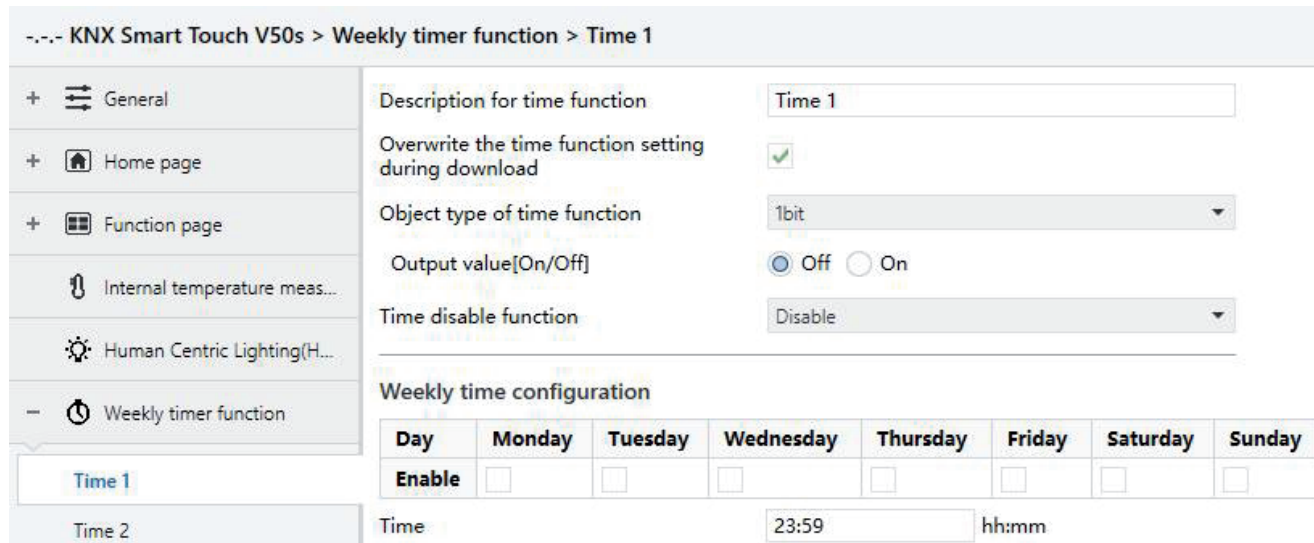

--- KNX Smart Touch V50s > Weekly timer function > Time 1

+ General  
 + Home page  
 + Function page  
 Internal temperature meas...  
 Human Centric Lighting(H...  
 - Weekly timer function

Description for time function: Time 1  
 Overwrite the time function setting during download:   
 Object type of time function: 1bit  
 Output value[On/Off]:  Off  On  
 Time disable function: Disable

Weekly time configuration

Day	Monday	Tuesday	Wednesday	Thursday	Friday	Saturday	Sunday
Enable	<input type="checkbox"/>	<input type="checkbox"/>	<input type="checkbox"/>	<input type="checkbox"/>	<input type="checkbox"/>	<input type="checkbox"/>	<input type="checkbox"/>

Time: 23:59 hh:mm

Fig. 5.6.1 “Time x” parameter window

#### Parameter “Description for time function”

This parameter is for setting the description of time function, up to 12 characters can be input (up to 6 Chinese characters are supported).

#### Parameter “Overwrite the time function setting during download”

This parameter is for setting whether to overwrite the time function setting during download.

If enabled, the weekly timer function on screen is subject to the ETS configuration after the application is downloaded.

If disabled, if the channel is already activated, the ETS configuration will not be transmitted to screen, but it is not activated at first, the channel of weekly timer function on screen is subject to the ETS.

#### Parameter “Object type of time function”

This parameter is for setting the data type of the sending value when timing time of time x arrives. Options:

- 1bit
- 1byte
- 2byte

- Parameter “Object datatype”

This parameter is for defining the data type of 1byte or 2byte.

When 1byte, Options:

- 1byte unsigned value
- 1byte[scene control]
- HVAC mode

When 2byte, Options:

- 2byte unsigned value
- Temperature value

- Parameter “Output value/ scene No.[...]”

This parameter is for setting the telegram value to be sent when it arrives the time of time x. The range depends on the options of the previous parameter.

## Parameter setting description in the ETS

### Parameter “Time disable function”

This parameter is for setting whether time function can be disabled or enabled via the object, or setting the trigger value of enable/disable timing. Options:

- Disable
- Disable=0/Enable=1
- Disable=1/Enable=0

### Weekly time configuration

The following parameters are for setting the time of time x, when time arrives, perform time x.

### Parameter “Monday/Tuesday/Wednesday/Thursday/Friday/Saturday/Sunday”

This parameter is for setting the day of a week to enable time x.

### Parameter “Time”

This parameter is for setting the specific time of time x. Options:

- Hours: 0..23
- Minutes 0..59

**Note:**The accuracy of RTC real-time clock inside the equipment is  $\pm 10\text{ppm}$ .

## 5.7 Parameter window “Scene Group function”

Parameter window “Scene Group function”, for enable scene group setting, up to 8 scene group functions can be configured, there are 8 outputs of each group, as shown as following.



Fig. 5.7(1) “Scene Group function” parameter window

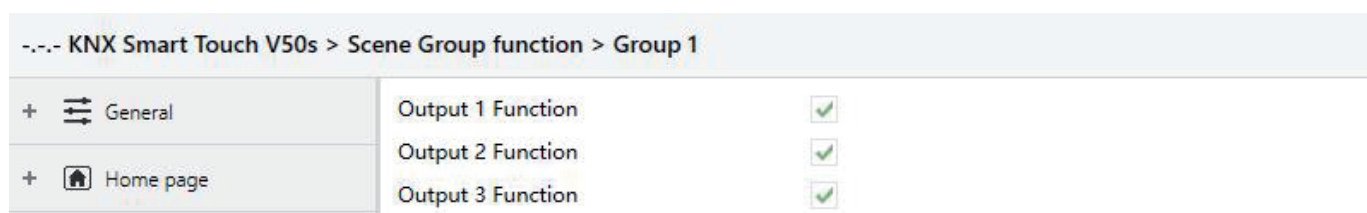

Fig. 5.7(2) “Group x” parameter window



## Parameter setting description in the ETS

--- KNX Smart Touch V50s > Scene Group function > Group 1 > Output 1 Function







+  General	Description for output 1 function	<input type="text"/>
+  Home page	Object type of Output 1	1bit <input type="text"/>
+  Function page	1->Trigger scene NO.[1..64,0=inactive]	0 <input type="text"/>
 Internal temperature meas...	Object value of Output 1	<input checked="" type="radio"/> 0 <input type="radio"/> 1
 Human Centric Lighting(H...	Delay time for sending[0..255]	0 <input type="text"/> *0.1s
+  Weekly timer function	2->Trigger scene NO.[1..64,0=inactive]	0 <input type="text"/>
-  Scene Group function	Object value of Output 1	<input checked="" type="radio"/> 0 <input type="radio"/> 1
	Delay time for sending[0..255]	0 <input type="text"/> *0.1s

Fig. 5.7(3) "Output y Function" parameter window

### Parameter "Scene Group x Function" (x=1~8)

This parameter is for setting whether to enable scene group x function, up to 8 scene groups.

### Parameter "Output y Function" (y=1~8)

This parameter is for setting whether to enable output y of scene group x, up to 8 output functions for each scene group. As 8 group functions are the same, and 8 output functions of each group as well, the following description only about one output of a group:

### Parameter "Description for Output y function" (y=1~8)

This parameter is for setting the name description for output y of group x, up to input 30 characters.

### Parameter "Object type of Output y" (y=1~8)

This parameter is for setting the object type of output y of group x. Options:

- 1bit
- 1byte
- 2byte

#### • Parameter "Object datatype"

This parameter is for setting the datatype of 1byte or 2byte.

When the datatype is 1byte, options:

- 1byte unsigned value
- HVAC moder

When the datatype is 2byte, options:

- 2byte unsigned value
- Temperature value

### Parameter "z->Trigger scene NO.[1~64,0=inactive]" (z=1~8)

This parameter is for setting the triggered scene number of output y of group x. Up to 8 triggered scene of each output can be configured. Options:

- 0..64, 0=inactive

#### • Parameter "Object value of Output y"

This parameter is for setting the output value, the range depends on the data type of output y:

When the datatype is 1bit, options:

- 0..1

When the datatype is 1byte-1byte unsigned value, options:

- 0..255

## Parameter setting description in the ETS

When the datatype is 1byte-HVAC mode, options:

- Comfort mode
- Standby mode
- Economy mode
- Frost/heat protection

When the datatype is 2byte-2byte unsigned value, options:

0..65535

When the datatype is 2byte-Temperature value, options:

- 5°C
- 4°C
- ...
- 45°C

• Parameter “ Delay time for sending [0..255]\*0.1s ”

This parameter is for setting the delay time for sending the output value to the bus. Options:

0..255

### 5.8 Parameter window “Logic function”

Parameter window “Logic function” as shown as Fig. 5.8, for enable logic function, up to 8 logic functions can be configured.

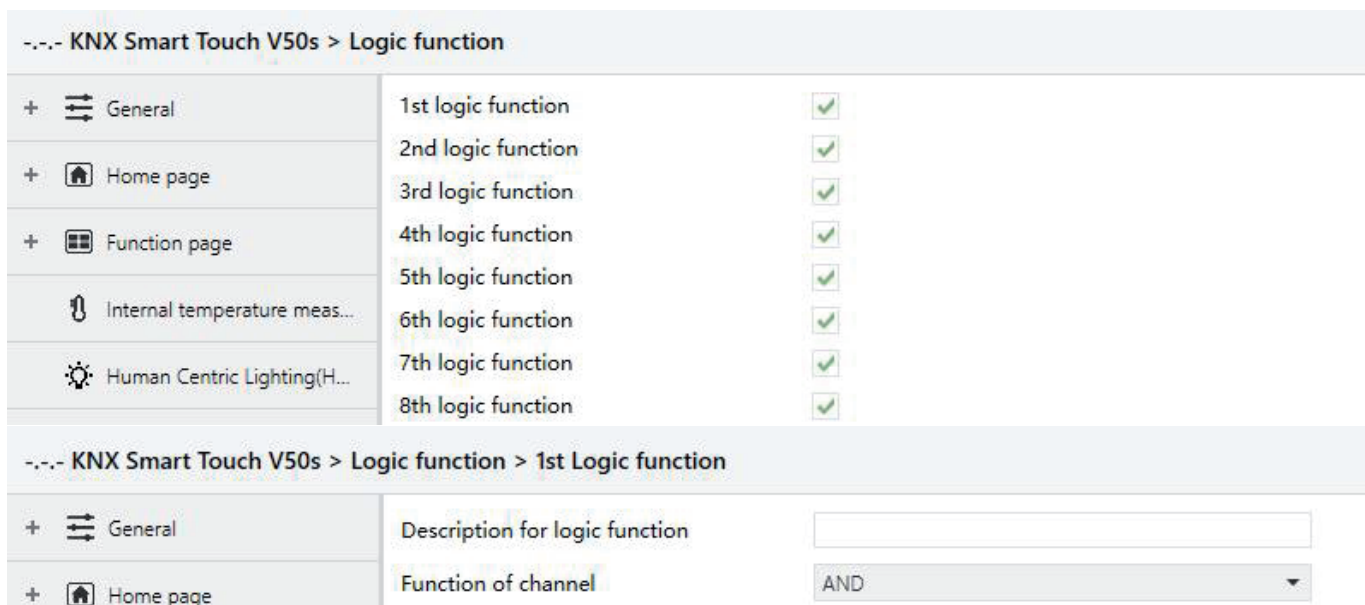

Fig. 5.8 “Logic function” parameter window

#### Parameter “1st/2nd/3rd... Logic function”

This parameter is for setting the setting interface of logic function, display corresponding logic function page when select. Up to enable 8 logic functions.

#### Parameter “Description for logic function”

This parameter is for setting the name description for logic function, up to input 30 characters.

## Parameter setting description in the ETS

### Parameter "Function of channel"

This parameter is for setting function of the channel. Options:

- AND
- OR
- XOR
- Gate forwarding
- Threshold comparator
- Format convert
- Delay function
- Staircase lighting

AND/OR/XOR: as the parameter is similar to the communication object (only the logic algorithm is different), the following parameters taking one options for example

#### 5.8.1 Parameter window "AND/OR/XOR"

The screenshot shows the '1st Logic function' parameter window in ETS. The window title is '--- KNX Smart Touch V50s > Logic function > 1st Logic function'. On the left is a navigation menu with options: General, Home page, Function page, Internal temperature meas..., Human Centric Lighting(H...), Weekly timer function, Scene Group function, Logic function, 1st Logic function (selected), 2nd Logic function, 3rd Logic function, 4th Logic function, 5th Logic function, 6th Logic function, 7th Logic function, and 8th Logic function. The main area contains the following settings:

- Description for logic function: [Text input field]
- Function of channel: AND (dropdown menu)
- Input a: Disconnected (dropdown menu)
  - Default value:  0  1
- Input b: Disconnected (dropdown menu)
  - Default value:  0  1
- Input c: Disconnected (dropdown menu)
  - Default value:  0  1
- Input d: Disconnected (dropdown menu)
  - Default value:  0  1
- Input e: Disconnected (dropdown menu)
  - Default value:  0  1
- Input f: Disconnected (dropdown menu)
  - Default value:  0  1
- Input g: Disconnected (dropdown menu)
  - Default value:  0  1
- Input h: Disconnected (dropdown menu)
  - Default value:  0  1
- Result is inverted:
- Read input object value after bus recovery:
- Output send when:  Receiving a new telegram  Every change of output object
- Send delay time: Base: None (dropdown menu)
- Factor: 1..255: 1 (spin box)

Fig. 5.8.1 "Logic function\_AND/OR/XOR" parameter window

## Parameter setting description in the ETS

### Parameter "Input a/b/c/d/e/f/g/h"

This parameter is for setting whether input x to calculate, whether to normally calculate or inverted calculate. Options:

- Disconnected
- Normal
- Inverted

Disconnected: not to calculate;

Normal: to directly calculate the input value;

Inverted: invert the input value, then to calculate. **Note: not to invert the initiate value.**

- **Parameter "Default value"**

This parameter is for setting the initial value of logic input x. Options:

- 0
- 1

### Parameter "Result is inverted"

This parameter is for setting whether to invert the logic calculation result. Options::

- No
- Yes

No: output directly; Yes: output after inverting.

### Parameter "Read input object value after bus recovery"

This parameter is for setting whether to send the read request to the logic input object after device bus recovery or finish programming.

### Parameter "Output send when"

This parameter is for setting the condition of sending logic result. Options::

- Receiving a new telegram
- Every change of output object

Receiving a new telegram: every time the object received a new input value will the logic result be sent to the bus;

Every change of output object: only when logic result has changed will it be sent to the bus.

**Tip: when in the first time to logic calculate, the logic result will be sent even if it has no change.**

### Parameter "Send delay time"

- Base:**
- None
  - 0.1s
  - 1s
  - ...
  - 10s
  - 25s

**Factor:** 1..255

This parameter is for setting the delay time for sending the logic calculation result to the bus. Delay time = Base × Factor, if option "None" of Base is selected, then there is no delay.

## Parameter setting description in the ETS

### 5.8.2 Parameter window “Gate forwarding”

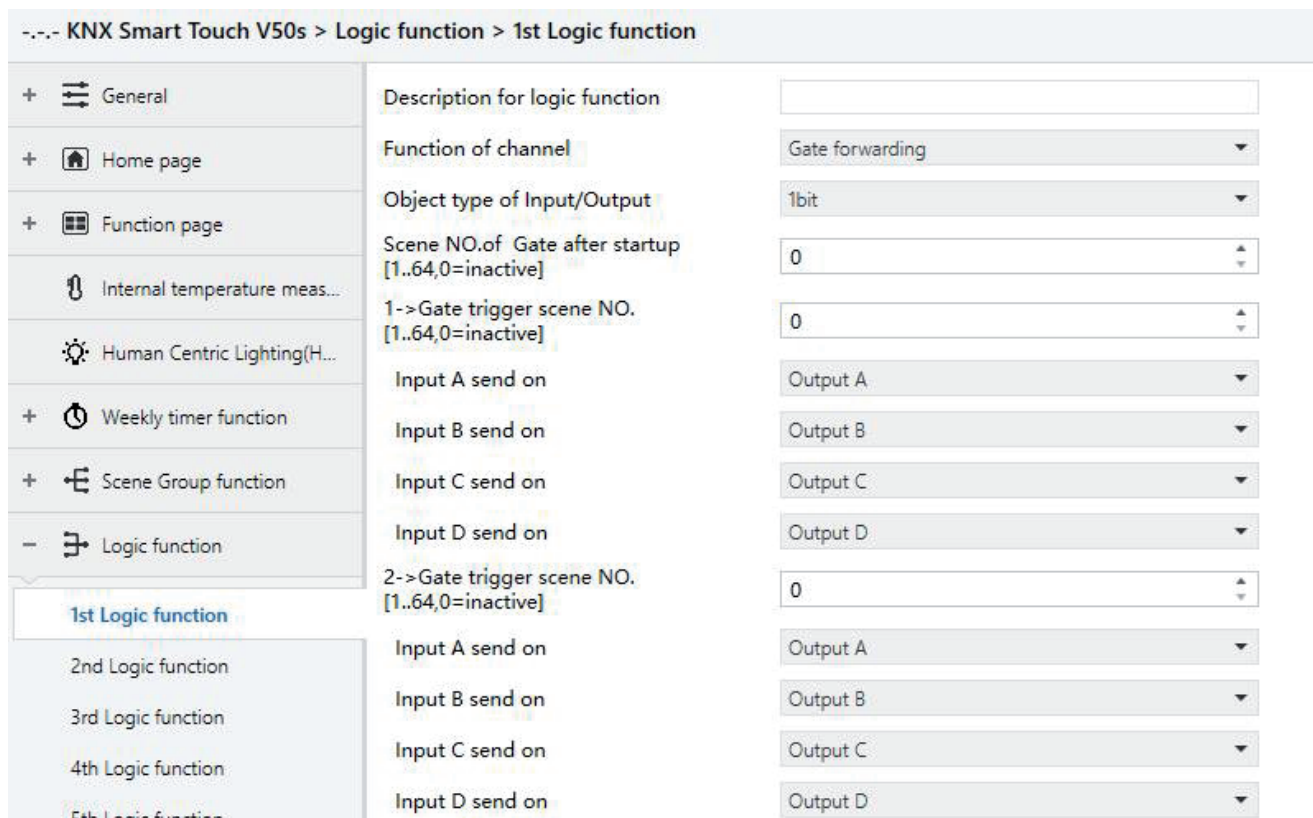

Fig. 5.8.2 “Logic function\_Gate forwarding” parameter window

#### Parameter “Object type of Input/Output”

This parameter is for setting the object type of input/output. Options:

- 1bit
- 4bit
- 1byte

#### Parameter “Scene NO. of Gate after startup [1..64, 0=inactive]”

This parameter is for setting the initial scene where logical gate forwarding can be performed by default after device starts, which needs to be configured in the parameters. Options:

- 1..64, 0=inactive

Note: gate scene is recommended to be selected before operating, or it will enable the initiate scene by default.

#### Parameter “z->Gate trigger scene NO.[1..64,0=inactive]” (z=1~8)

This parameter is for setting scene number of logic gate forwarding. Up to 8 trigger scene number can be set for each logic. Options:

- 1..64, 0=inactive

- Parameter “Input A/B/C/D send on”

This parameter is for setting the output of input X (X=A/B/C/D) after gate forwarding. Options:

- Output A
- Output B
- ...
- Output B,C,D

According to the options, one input can be forwarded into one or more outputs, the output value is the same as the input value

## Parameter setting description in the ETS

### 5.8.3 Parameter window “Threshold comparator”

--- KNX Smart Touch V50s > Logic function > 1st Logic function









+  General	Description for logic function	<input type="text"/>
+  Home page	Function of channel	Threshold comparator
+  Function page	Threshold value data type	1byte unsigned value (DPT5.010)
 Internal temperature meas...	Threshold value	127
 Human Centric Lighting(H...	If Object value < Threshold value	Do not send telegram
+  Weekly timer function	If Object value = Threshold value	Do not send telegram
+  Scene Group function	If Object value != Threshold value	Do not send telegram
-  Logic function	If Object value > Threshold value	Do not send telegram
<b>1st Logic function</b>	If Object value <= Threshold value	Do not send telegram
2nd Logic function	If Object value >= Threshold value	Do not send telegram
3rd Logic function	Output send when	<input checked="" type="radio"/> Receiving a new telegram <input type="radio"/> Every change of output object
	Send delay time: Base	None
	Factor: 1..255	1

Fig. 5.8.3 “Logic function\_Threshold comparator” parameter window

#### Parameter “Threshold value data byte”

This parameter is for setting the threshold value data type. Options:

4bit value (DPT3.007)	4byte unsigned value [0..4294967295]
1byte unsigned value (DPT5.010)	Ext. temperature value (DPT 9.001)
2byte unsigned value (DPT7.001)	Ext. humidity value (DPT 9.007)
2byte signed value (DPT8.x)	Illuminance value (DPT 9.004)
2byte float value (DPT9.x).	CO2 value (DPT 9.008)

#### • Parameter “Threshold value”

This parameter is for setting threshold value, the range depends on the data type. Options:

4bit value (DPT3.007) 0..15 / 1byte unsigned value (DPT5.010) 0..255 /
2byte unsigned value (DPT7.001) 0..65535 / 2byte signed value (DPT8.x) -32768..32767 /
2byte float value (DPT9.x) -670760...670760 / 4byte unsigned value [0..4294967295] 0..4294967295 /
Ext. temperature value (DPT 9.001) -20..95°C / Ext. humidity value (DPT 9.007) 0..100% /
Illuminance value (DPT 9.004) 0..65535lux

#### Parameter “Hysteresis threshold value”

This parameter is visible when object datatype is selected “2byte float value (DPT9.x)”, “Illuminance value (DPT 9.004)”. Set the hysteresis threshold value. Options:

0..500



## Parameter setting description in the ETS

### Parameter “If Object value<Threshold value”

- Parameter “If Object value=Threshold value”
- Parameter “If Object value!=Threshold value”
- Parameter “If Object value>Threshold value”
- Parameter “If Object value<=Threshold value”
- Parameter “If Object value>=Threshold value”

These parameters are for setting the logic result values that should be sent when threshold value less than, equal to, not equal to, greater than, less than and equal to, or greater and equal to the setting valve. When object datatype is selected “2byte float value (DPT9.x)” or “Illuminance value (DPT 9.004)”, can only set the object value less than or greater than threshold value. Options:

- Do not send telegram
- Send value “0”
- Send value “1”

Do not send telegram: not consider to select this option;

Send value “0”/“1”: when condition is satisfied, send telegram 0 or 1.

If there is a conflict between the setting options of the parameters, it is based on the value that should be sent, which meets the final parameter condition.

**For example: parameter “If Object value=Threshold value” is set to be “Send value “0” ”; parameter “If Object value<=Threshold value” is set to be “Send value “1” ”; when object value is equal to the threshold value, then the logic result will send “1”.**

### Parameter “Output send when”

This parameter is for setting the condition of sending logic result. Options:

- Receiving a new telegram
- Every change of output object

Receiving a new telegram: every time the object received a new input value will the logic result be sent to the bus;

Every change of output object: only when logic result has changed will it be sent to the bus.

**Tip: when in the first time to logic algorithm, the logic result will be sent even if it has no change.**

### Parameter “Send delay time: Base”

- Base:      None  
             0.1s  
             1s  
             ...  
             25s

Factor:    1..255

This parameter is for setting the delay time for sending the logic algorithm result to the bus. Delay time = Base x Factor, if option “None” of Base is selected, then there is no delay.

#### 5.8.4 Parameter window “Format convert”

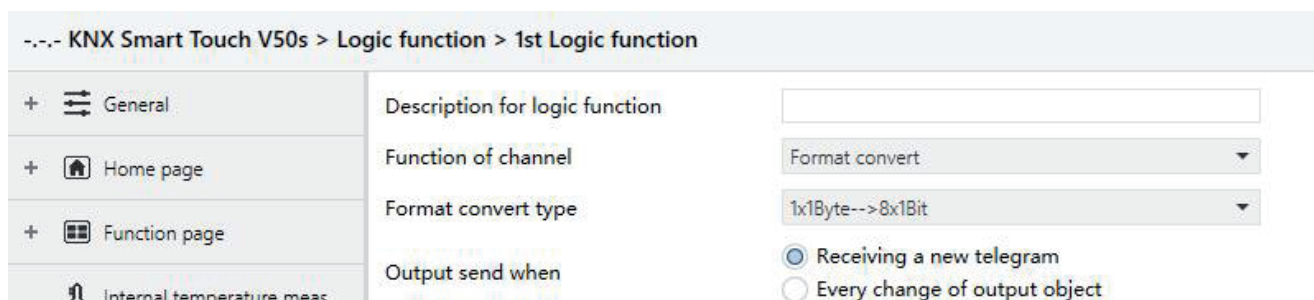

Fig. 5.8.4 “Logic function \_Format convert” parameter window



## Parameter setting description in the ETS

### Parameter "Format convert type"

This parameter is for setting the format convert type. Options:

- 2x1bit-->1x2bit
- 8x1bit-->1x1 byte
- 1x1byte-->1x2byte
- 2x1byte-->1x2byte
- 2x2byte-->1x4byte
- 1x1byte-->8x1bit
- 1x2byte-->2x1byte
- 1x4byte-->2x2byte
- 1x3byte-->3x1byte
- 3x1byte-->1x3byte

### Parameter "Output send when"

This parameter is for setting the condition of sending logic result. Options:

- Receiving a new telegram
- Every change of output object

Receiving a new telegram: every time the object received a new input value will the logic result be sent to the bus;

Every change of output object: only when logic result has changed will it be sent to the bus.

**Tip:** when in the first time to logic algorithm, the logic result will be sent even if it has no change.

### 5.8.5 Parameter window "Delay function"

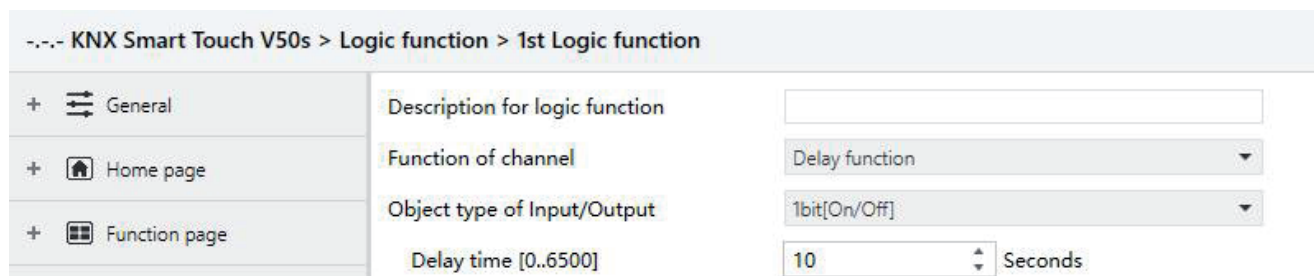

Fig. 5.8.5 "Delay function" parameter window

### Parameter "Object type of Input/Output"

This parameter is for setting the object type of input/output. Options:

- 1bit[On/Off]
- 1byte[0..100%]
- 1byte[0..255]
- 2byte[Float]
- 2byte[0..65535]

### Parameter "Delay time [0..6500]s"

This parameter is for setting the delay time that output object forwards the value when the input object receives the telegram. Options:

- 0..6500

**Note:** Receive telegram again in delay time, re-timing.

## Parameter setting description in the ETS

### 5.8.6 Parameter window “Staircase lighting”

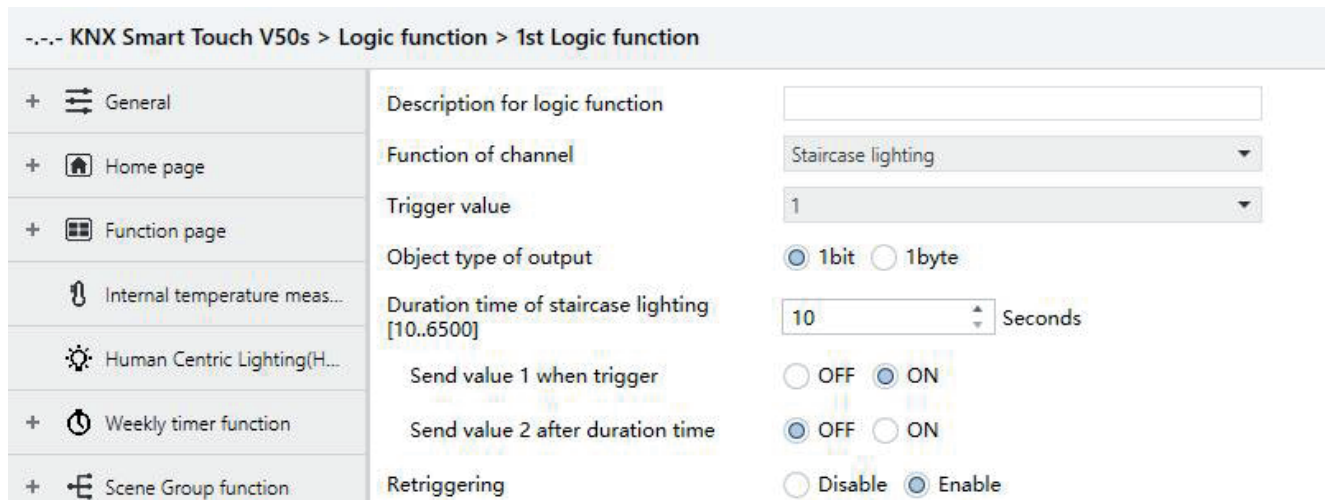

The screenshot shows the ETS parameter window for a logic function. The breadcrumb path is: KNX Smart Touch V50s > Logic function > 1st Logic function. The left sidebar contains a menu with options: General, Home page, Function page, Internal temperature meas..., Human Centric Lighting(H..., Weekly timer function, and Scene Group function. The main area displays the following parameters:

- Description for logic function: [Empty text field]
- Function of channel: Staircase lighting (dropdown menu)
- Trigger value: 1 (dropdown menu)
- Object type of output:  1bit  1byte
- Duration time of staircase lighting [10..6500]: 10 (spin box) Seconds
- Send value 1 when trigger:  OFF  ON
- Send value 2 after duration time:  OFF  ON
- Retriggering:  Disable  Enable

Fig. 5.8.6 “Staircase lighting” parameter window

#### Parameter “Trigger value”

This parameter is for setting the telegram value of the object “Trigger value”. Options:

0  
1  
0 or 1

#### Parameter “Object type of output”

This parameter is for setting the object type of output. Options:

1bit  
1byte

#### Parameter “Duration time of staircase lighting [10..6500]s”

This parameter is for setting duration time of staircase lighting after the stair light power on. Options:

10..6500

#### Parameter “Send value 1 when trigger”

##### • Parameter “Send value 2 after duration time”

These parameters are for setting the value to send. Send value 1 when trigger, and then send value 2 after duration time. Options display according to the output object datatype.

When 1 bit, options:

OFF  
ON

When 1 byte, options:

0..255

#### Parameter “Retriggering”

This parameter is for setting whether to trigger re-timing when received trigger value in delay time. Options:

Disable  
Enable

## Description of Communication Object

### 6. Description of Communication Object

The communication object is the medium to communicate other device on the bus, namely only the communication object can communicate with the bus.

NOTE: “C” in “Flag” column in the below table means enable the communication function of the object; “W” means value of object can be written from the bus; “R” means the value of the object can be read by the other devices; “T” means the object has the transmission function; “U” means the value of the object can be updated.

#### 6.1 “General” Communication Object

Nur	Name	Object Function	Description	Group Address	Length	C	R	W	T	U	Data Type	Priority
918	General	Screen locking			1 bit	C	-	W	-	-	enable	Low
919	General	In operation			1 bit	C	R	-	T	-	switch	Low
920	General	Date			3 bytes	C	-	W	-	-	date	Low
921	General	Time			3 bytes	C	-	W	-	-	time of day	Low
922	General	Day/Night			1 bit	C	-	W	-	-	day/night	Low
923	General	Screen backlight brightness			1 byte	C	-	W	-	-	percentage (0..100%)	Low
924	General	Colourful strip trigger			1 bit	C	-	W	-	-	trigger	Low
925	General	Colourful strip setting			3 bytes	C	-	W	-	-	RGB value 3x(0..255)	Low
926	General	Proximity sense, 1bit value			1 bit	C	-	W	T	-	switch	Low
927	General	Password trigger, 1bit value			1 bit	C	-	-	T	-	switch	Low
928	General	Summer time, status			1 bit	C	R	-	T	-	enable	Low
929	General	Screen backlight on/off			1 bit	C	-	W	-	-	switch	Low
930	General	Colourful strip flashing			1 bit	C	-	W	-	-	trigger	Low
931	General	Alarm input			1 bit	C	-	W	T	U	alarm	Low
932	General	Alarm message			14 bytes	C	-	W	-	-	Character String (ISO 8859-1)	Low
933	General	Alarm acknowledge			1 bit	C	-	-	T	-	acknowledge	Low
934	Screensaver-Items 1	Temperature value			2 bytes	C	-	W	T	U	temperature (°C)	Low
935	Screensaver-Items 2	Humidity value			2 bytes	C	-	W	T	U	humidity (%)	Low
936	Screensaver-Items 3	PM2.5 value			2 bytes	C	-	W	T	U	pulses	Low
937	Screensaver-Items 4	PM10 value			2 bytes	C	-	W	T	U	pulses	Low

Fig. 6.1 “General” communication object

No.	Object function	Name	Data - Type	Flag	DPT
918	Screen locking	General	1bit	C,W	1.003 enable
The communication object is used to lock the screen. After screen locked, the operation on the screen will not be responded, but can still receive the bus telegram. Telegram value: 0 — Lock 1 — Unlock					
919	In operation	General	1bit	C,R,T	1.001 switch
The communication object is used to periodically send a telegram “1” to the bus to indicate that the device					
920	Date	General	3bytes	C,W	11.001 date
The communication object is used to modify the display date on the screen through the bus.					
921	Time	General	3bytes	C,W	10.001 time of day
The communication object is used to modify the display time on the screen through the bus.					
922	Day/Night	General	1bit	C,W C,T	1.024 day/night
This communication object is used to send day/night status to the bus. The day/night state can be switched according to the time point or sunrise and sunset time, or the telegram value can be switched through the bus. Telegram value: 0 — Day 1 — Night Parameter “Send day/night status” is selected No, the flags is C,W; When depend to certain time or sunrise&sunset, the flags is C,T.					
923	Screen backlight brightness	General	1byte	C,W	5.001percentage(0..100%)
The communication object is used to modify the screen backlight brightness. Brightness output range: 10~100%, when the telegram value is less than 10%, directly output 10% brightness. Object is visible when the parameter “Screen brightness can be changed via bus” is enabled.					
924	Colourful strip setting	General	1bit	C,W	1.017 trigger
The communication object is visible when the colorful strip is enabled, and is used to trigger the indication function of the colorful strip through the bus.					
925	Colourful strip setting	General	3byte	C,W	232.600 RGB value 3x(0..255)
The communication object is visible when option “Receive a 3byte value” of parameter“Colour setting” is selected, for receiving 3byte value.					

## Description of Communication Object

No.	Object function	Name	Data - Type	Flag	DPT
926	Proximity sense, 1 bit value Proximity sense, scene NO. Proximity sense, 1 byte value	General	1bit 1byte	C,W,T	1.001 switch 17.001 scene number 5.010 counter pulses (0..255) 5.001 percentage (0..100%)
The communication object is visible when status feedback of proximity sensor is enabled and output value is selected. When proximity approaching or leaving, it will send telegram to the bus. The range of value is determined by the selected data type.					
927	Password trigger, 1bit value Password trigger, scene NO. Password trigger, 1 byte value	General	1bit 1byte	C,T	1.001 switch 17.001 scene number 5.010 counter pulses (0..255) 5.001 percentage (0..100%)
The communication object is visible when password function is enabled and output value is selected. The range of value is determined by the selected data type.					
928	Summer time status	General	1bit	C,R,T	1.003enable
The communication object is used to send the status telegrams of the summer time to the bus. Telegrams: 0 — Summer time enable 1 — Summer time disable					
930	Colorful strip flashing	General	1bit	C,W	1.017 trigger
The communication object is used to receive the telegrams from bus to trigger the colorful strip flashing. Telegram value: 0 — No trigger 1 — Trigger					
931	Alarm input	General	1bit	C,W,T,U	1.005 alarm
The communication object is used to receive the alarm signal from bus. Telegram value: 0 — No trigger 1 — Trigger					
932	Alarm message	General	14byte	C,W	16.001 character string (ISO 8859-1)
The communication object is used to receive the warning message displayed on the screen from bus. When no value is received initially, the warning pop-up is displayed empty.					
933	Alarm acknowledge	General	1bit	C,T	1.016 acknowledge
When the user clicks on the screen to acknowledge the warning message, the communication object sends an acknowledge telegram to the bus, and the telegram value is 1.					
934	Temperature value	Screensaver-Items 1	2byte	C,W,T,U	9.001 temperature
934	Humidity value	Screensaver-Items 1	2byte	C,W,T,U	9.007 humidity
934	PM2.5/PM10 value	Screensaver-Items 1	2byte	C,W,T,U	7.001 pulse 9.030 concentration( $\mu\text{g}/\text{m}^3$ )
934	CO2 value	Screensaver-Items 1	2byte	C,W,T,U	7.001 pulse 9.008 parts/million(ppm)
934	VOC value	Screensaver-Items 1	2byte	C,W,T,U	7.001 pulse 9.030 concentration( $\mu\text{g}/\text{m}^3$ ) 9.008 parts/million(ppm)
934	Brightness value	Screensaver-Items 1	2byte	C,W,T,U	7.013 brightness(lux) 9.004 lux
934	Wind speed	Screensaver-Items 1	2byte	C,W,T,U	9.005 speed 9.028 wind speed
The communication object is used for receiving the air quality information sent from bus, the corresponding value will be updated to screen display. Up to display 4 items of air quality information on the screen saver, you can set to display temperature, humidity, PM2.5, CO2, VOC, brightness and wind speed. The object data type of value is determined by the parameters. All objects will be sent read request to bus when voltage recovery.					

Table 6.1 "General" communication object table

## Description of Communication Object

### 6.2 “Home page” Communication Object

Number	Name	Object Function	Description	Group Address	Length	C	R	W	T	U	Data Type	Priority
915	Home page	External temperature value			2 bytes	C	-	W	T	U	temperature (°C)	Low
917	Home page	External humidity value			2 bytes	C	-	W	T	U	humidity (%)	Low

Fig. 6.2 “Home page” communication object

The objects of external temperature , humidity will be sent read request to bus when device restarted.

No.	Object function	Name	Data - Type	Flag	DPT
915	External temperature value	Home page	2bytes	C,W,T,U	9.001 temperature (°C)
The communication object is used for receiving a temperature measurement value sent from a temperature sensor on the bus. Range:-50~99.9°C					
917	External humidity value	Home page	2bytes	C,W,T,U	9.007 humidity (%)
The communication object is used to receive humidity measurements sent from the humidity sensor on the bus. Range:0~100%					

Table 6.2 “Home page” communication object table

### 6.3 “Function Page” communication object

#### 6.3.1 “Multifunction (Lighting/Blind/Scene/Value send)”Communication Object

Number	Name	Object Function	Description	Group Address	Length	C	R	W	T	U	Data Type	Priority
1	Page 1-Icon 1	Switch			1 bit	C	-	-	T	-	switch	Low
3	Page 1-Icon 1	Switch, status			1 bit	C	-	W	T	U	switch	Low
49	Page 1-...	Locking object			1 bit	C	-	W	-	-	enable	Low
<b>Switch</b>												
1	Page 1-Icon 1	Switch			1 bit	C	-	-	T	-	switch	Low
49	Page 1-...	Locking object			1 bit	C	-	W	-	-	enable	Low
<b>Press/Release switch</b>												
1	Page 1-Icon 1	Switch			1 bit	C	-	-	T	-	switch	Low
3	Page 1-Icon 1	Switch, status			1 bit	C	-	W	T	U	switch	Low
4	Page 1-Icon 1	Relative dimming			4 bit	C	-	W	T	-	dimming control	Low
49	Page 1-...	Locking object			1 bit	C	-	W	-	-	enable	Low
<b>Relative dimming</b>												
1	Page 1-Icon 1	Switch			1 bit	C	-	-	T	-	switch	Low
2	Page 1-Icon 1	Brightness dimming			1 byte	C	-	-	T	-	percentage (0..100%)	Low
3	Page 1-Icon 1	Switch, status			1 bit	C	-	W	T	U	switch	Low
5	Page 1-Icon 1	Brightness, status			1 byte	C	-	W	T	U	percentage (0..100%)	Low
49	Page 1-...	Locking object			1 bit	C	-	W	-	-	enable	Low
<b>Brightness dimming</b>												
1	Page 1-Icon 1	Switch			1 bit	C	-	-	T	-	switch	Low
2	Page 1-Icon 1	Brightness dimming			1 byte	C	-	-	T	-	percentage (0..100%)	Low
3	Page 1-Icon 1	Switch, status			1 bit	C	-	W	T	U	switch	Low
4	Page 1-Icon 1	Relative dimming			4 bit	C	-	W	T	-	dimming control	Low
5	Page 1-Icon 1	Brightness, status			1 byte	C	-	W	T	U	percentage (0..100%)	Low
49	Page 1-...	Locking object			1 bit	C	-	W	-	-	enable	Low
<b>Relative+Brightness dimming</b>												
1	Page 1-Icon 1	Switch			1 bit	C	-	-	T	-	switch	Low
2	Page 1-Icon 1	Brightness value			1 byte	C	-	-	T	-	percentage (0..100%)	Low
3	Page 1-Icon 1	Switch, status			1 bit	C	-	W	T	U	switch	Low
4	Page 1-Icon 1	Colour temperature value			2 bytes	C	-	-	T	-	absolute colour temperature (K)	Low
5	Page 1-Icon 1	Brightness, status			1 byte	C	-	W	T	U	percentage (0..100%)	Low
6	Page 1-Icon 1	Colour temperature, status			2 bytes	C	-	W	T	U	absolute colour temperature (K)	Low
49	Page 1-...	Locking object			1 bit	C	-	W	-	-	enable	Low
<b>Brightness+Colour Temperature_Normal</b>												
1	Page 1-Icon 1	Switch			1 bit	C	-	-	T	-	switch	Low
2	Page 1-Icon 1	Cool white brightness			1 byte	C	-	-	T	-	percentage (0..100%)	Low
3	Page 1-Icon 1	Switch, status			1 bit	C	-	W	T	U	switch	Low
4	Page 1-Icon 1	Warm white brightness			1 byte	C	-	-	T	-	percentage (0..100%)	Low
5	Page 1-Icon 1	Brightness, status			1 byte	C	-	W	T	U	percentage (0..100%)	Low
6	Page 1-Icon 1	Colour temperature, status			2 bytes	C	-	W	T	U	absolute colour temperature (K)	Low
49	Page 1-...	Locking object			1 bit	C	-	W	-	-	enable	Low

Brightness+Colour Temperature\_Directly(.) & Brightness+Colour Temperature



## Description of Communication Object

1	Page 1-Icon 1	Switch	1 bit	C - - T -	switch	Low
2	Page 1-Icon 1	Cool white brightness	1 byte	C - - T -	percentage (0..100%)	Low
3	Page 1-Icon 1	Switch, status	1 bit	C - W T U	switch	Low
4	Page 1-Icon 1	Warm white brightness	1 byte	C - - T -	percentage (0..100%)	Low
5	Page 1-Icon 1	Cool white brightness, status	1 byte	C - W T U	percentage (0..100%)	Low
6	Page 1-Icon 1	Warm white brightness, status	1 byte	C - W T U	percentage (0..100%)	Low
49	Page 1-...	Locking object	1 bit	C - W - -	enable	Low
<b>Brightness+Colour Temperature_Directly(.) &amp; Warm/Cool white brightness</b>						
1	Page 1-Icon 1	Send 1bit value	1 bit	C - - T -	switch	Low
2	Page 1-Icon 1	Send 1bit value, long	1 bit	C - - T -	switch	Low
49	Page 1-...	Locking object	1 bit	C - W - -	enable	Low
<b>Value sender</b>						
1	Page 1-Icon 1	Open/Close	1 bit	C - W T -	open/close	Low
2	Page 1-Icon 1	Stop	1 bit	C - - T -	step	Low
3	Page 1-Icon 1	Curtain position	1 byte	C - - T -	percentage (0..100%)	Low
5	Page 1-Icon 1	Curtain position, status	1 byte	C - W T U	percentage (0..100%)	Low
49	Page 1-...	Locking object	1 bit	C - W - -	enable	Low
<b>Curtain position</b>						
1	Page 1-Icon 1	Up/Down	1 bit	C - W T -	up/down	Low
2	Page 1-Icon 1	Stop	1 bit	C - - T -	step	Low
3	Page 1-Icon 1	Blind position	1 byte	C - - T -	percentage (0..100%)	Low
5	Page 1-Icon 1	Blind position, status	1 byte	C - W T U	percentage (0..100%)	Low
49	Page 1-...	Locking object	1 bit	C - W - -	enable	Low
<b>Roller blind position</b>						
1	Page 1-Icon 1	Up/Down	1 bit	C - W T -	up/down	Low
2	Page 1-Icon 1	Stop/Slat adj.	1 bit	C - - T -	step	Low
3	Page 1-Icon 1	Blind position	1 byte	C - - T -	percentage (0..100%)	Low
4	Page 1-Icon 1	Slat position	1 byte	C - - T -	percentage (0..100%)	Low
5	Page 1-Icon 1	Blind position, status	1 byte	C - W T U	percentage (0..100%)	Low
6	Page 1-Icon 1	Slat position, status	1 byte	C - W T U	percentage (0..100%)	Low
49	Page 1-...	Locking object	1 bit	C - W - -	enable	Low
<b>Venetian blind position and slat</b>						
1	Page 1-Icon 1	Open/Close	1 bit	C - W T -	open/close	Low
2	Page 1-Icon 1	Stop	1 bit	C - - T -	step	Low
49	Page 1-...	Locking object	1 bit	C - W - -	enable	Low
<b>Curtain step/move</b>						
1	Page 1-Icon 1	Up/Down	1 bit	C - W T -	up/down	Low
2	Page 1-Icon 1	Stop	1 bit	C - - T -	step	Low
49	Page 1-...	Locking object	1 bit	C - W - -	enable	Low
<b>Blind(up/down/stop)</b>						
1	Page 1-Icon 1	Recall/storage scene NO.	1 byte	C - W T -	scene control	Low
49	Page 1-...	Locking object	1 bit	C - W - -	enable	Low
<b>Scene control</b>						
3	Page 1-Icon 1	Switch, status	1 bit	C - W T U	switch	Low
<b>Switch indicator</b>						

Fig. 6.3.1 "Multifunction (Lighting/Blind/Scene/Value send)" communication object

For multifunction, when the sending status read request is enabled, all status objects will be sent read request to bus after the delay time. **Note: the switch status is not sent read request when Brightness+Colour**

Temperature is selected.

No.	Object function	Name	Data - Type	Flag	DPT
1	Switch	Page 1-{{Icon 1}}	1bit	C, T	1.001 switch
The communication object is used to send the on / off telegram to the bus, applies to switch, press/release switch, relative/brightness dimming, and brightness + colour temperature control. Telegrams: 1 — Turn on the light 0 — Turn off the light The name in parentheses changes with the parameter "Description for Icon x". If description is empty, display "Page x - Icon y" by default. The same below.					
3	Switch Status	Page 1-{{Icon 1}}	1bit	C,W,T,U	1.001 switch
The communication object is used to receive the on / off status from other bus devices, and feedback to screen display, applies to switch, relative/brightness dimming, brightness+ colour temperature control and switch indicator.					
4	Relative dimming	Page 1-{{Icon 1}}	4 bit	C,W,T	3.007 dimming control
The communication object applies to relative dimming, is used for sending the relative dimming telegram to the bus, such as brighter, darker, or stop-dimming telegram.					

## Description of Communication Object

No.	Object function	Name	Data - Type	Flag	DPT
2	Brightness value	Page 1-{{Icon 1}}	1byte	C,T	5.001 percentage(0..100%)
5	Brightness, status	Page 1-{{Icon 1}}	1byte	C,W,T,U	5.001 percentage(0..100%)
These two communication objects apply to brightness dimming. Telegrams: 0~100% Obj.2: used for sending dimming telegrams to the bus, that is, sending the brightness value. Obj.5: used for receiving brightness status responded from dimming actuator.					
4	Colour temperature value	Page 1-{{Icon 1}}	2byte	C,T	7.600 absolute colour temperature
6	Colour temperature, status	Page 1-{{Icon 1}}	2byte	C,W,T,U	7.600 absolute colour temperature
These two communication objects apply to colour temperature adjustment of monochrome lamp/two-colour lamp. Telegrams: 2000...7000 K Obj.4: under normal control, used for sending the control telegram of the colour temperature to the bus. Obj.6: under normal or directly control & (Brightness+Colour Temperature), used for receiving the control telegram of the colour temperature from bus.					
2	Cool white brightness	Page 1-{{Icon 1}}	1byte	C,T	5.001 percentage(0..100%)
5	Cool white brightness, status	Page 1-{{Icon 1}}	1byte	C,W,T,U	5.001 percentage(0..100%)
Under the directly control, these two communication objects apply to cool white brightness control of two-colour lamp. Telegrams: 0...100% Obj.2: under directly control, used for sending the cool white dimming telegram to the bus, that is, sending the cool cool brightness value. Obj.5: under directly control & (Warm/Cool white brightness), used for receiving the cool white brightness status responded from the dimming actuator.					
4	Warm white brightness	Page 1-{{Icon 1}}	1byte	C,T	5.001 percentage(0..100%)
6	Warm white brightness, status	Page 1-{{Icon 1}}	1byte	C,W,T,U	5.001 percentage(0..100%)
Under the directly control, these two communication objects apply to warm white brightness control of two-colour lamp. Telegrams: 0...100% Obj.4: under directly control, used for sending the warm white dimming telegram to the bus, that is, sending the warm white brightness value. Obj.6: under directly control & (Warm/Cool white brightness), used for receiving the warm white brightness status responded from the dimming actuator.					
1	Send 1bit value Send 2bit value Send 4bit value Send 1byte unsigned value Send 1byte percentage value Send 2byte unsigned value Send 2byte signed value Send 4byte value Send 4byte float value	Page 1-{{Icon 1}}	1bit 2bit 4bit 1byte 2byte 4byte	C,T	1.001 switch 2.001 switch control 3.007 dimming control 5.010 counter pulses(0..255) 5.001 percentage(0..100%) 7.001 pulses 8.001 pulses difference 12.001 counter pulses 14.x float value
The communication object is used to send the preset output value of the parameter, and if the long press operation is distinguished from the short press operation, only the output value of the short press operation is sent. The object type and value range are determined by the data type set by the parameter.					
2	Send 1bit value, long Send 2bit value, long Send 4bit value, long Send 1byte unsigned value, long Send 1byte percentage value, long Send 2byte unsigned value, long Send 2byte signed value, long	Page 1-{{Icon 1}}	1bit 2bit 4bit 1byte 2byte	C,T	1.001 switch 2.001 switch control 3.007 dimming control 5.010 counter pulses(0..255) 5.001 percentage(0..100%) 7.001 pulses 8.001 pulses difference
The communication object is visible when the long press operation is distinguished from the short press operation, used to send the output value when long operation.					
1	Open/Close	Page 1-{{Icon 1}}	1bit	C,W, T	1.009 open/close
2	Stop	Page 1-{{Icon 1}}	1bit	C, T	1.007 step
3	Curtain position	Page 1-{{Icon 1}}	1byte	C, T	5.001 percentage
5	Curtain position, status	Page 1-{{Icon 1}}	1byte	C,W,T,U	5.001 percentage(0..100%)
Curtain position: apply to open and close curtain. Support to open, close, stop, position adjustment and position status feedback. Obj.1: used for sending the telegram to the bus, to control curtain open/close. Telegrams:: 1 — Close the curtain 0 — Open the curtain Obj.2: used for sending the telegram to the bus, to stop curtain movement. Telegrams: 0/1 — Stop Obj.3: used for sending a telegram to control the position of the curtain to the bus. Telegrams: 0...100% Obj.5: used for receiving a curtain position status in response to the window curtain actuator on the bus. Telegrams: 0...100%					



## Description of Communication Object

No.	Object function	Name	Data - Type	Flag	DPT
1	Up/Down	Page 1-{{Icon 1}}	1bit	C,W, T	1.008 up/down
2	Stop	Page 1-{{Icon 1}}	1bit	C, T	1.007 step
3	Blind position	Page 1-{{Icon 1}}	1byte	C, T	5.001 percentage
5	Blind position, status	Page 1-{{Icon 1}}	1byte	C,W,T,U	5.001 percentage(0..100%)
<p>Roller blind position: apply to a roller blind without slat. Support to up, down, stop, position adjustment and position status feedback.                      Obj.1: used for sending the telegram to the bus, to control blind up/down. Telegrams:                      1 — Move down                      0 — Move up                      Obj.3: used for sending a telegram to control the position of the roller blind to the bus. Telegrams: 0...100%                      Obj.5: used for receiving a roller blind position status in response to the roller blind actuator on the bus. Telegrams: 0...100%                      Obj.2 is the same as above.</p>					
1	Up/Down	Page 1-{{Icon 1}}	1bit	C,W,T	1.008 up/down
2	Stop	Page 1-{{Icon 1}}	1bit	C, T	1.007 step
3	Blind position	Page 1-{{Icon 1}}	1byte	C, T	5.001 percentage(0..100%)
4	Slat position	Page 1-{{Icon 1}}	1byte	C, T	5.001 percentage(0..100%)
5	Blind position, status	Page 1-{{Icon 1}}	1byte	C,W,T,U	5.001 percentage(0..100%)
6	Slat position, status	Page 1-{{Icon 1}}	1byte	C,W,T,U	5.001 percentage(0..100%)
<p>Venetian blind position and slat: apply to a blind with slat. Support to up, down, stop, position and slat adjustment, position and slat status feedback.                      Obj.1, Obj.3 and Obj.5 are same as above.                      Obj.2: used for sending a telegram to the bus to stop the curtain movement or adjust the slat angle. Telegrams:                      1 — Stop/Slat adj. Down                      0 — Stop/Slat adj. Up                      Obj.4: used for sending a telegram to control the position of the blind to the bus. Telegrams: 0...100%                      Obj.6: used for receiving a blind position status in response to the blind actuator on the bus. Telegrams: 0...100%</p>					
1	Open/Close	Page 1-{{Icon 1}}	1bit	C,W, T	1.009 open/close
2	Stop	Page 1-{{Icon 1}}	1bit	C, T	1.007 step
<p>Curtain step/move: these two communication objects apply to open and close curtain. Support to open, close, stop.                      Obj.1: used for sending the telegram to the bus, to control curtain open/close. Telegrams:                      1 — Close the curtain                      0 — Open the curtain                      Obj.2: used for sending the telegram to the bus, to stop curtain movement. Telegrams:                      0/1 — Stop</p>					
1	Up/Down	Page 1-{{Icon 1}}	1bit	C,W,T	1.008 up/down
2	Stop	Page 1-{{Icon 1}}	1bit	C, T	1.007 step
<p>Roller blind step/move: these two communication objects apply to roller blind. Support to up, down, stop.                      Obj.1: used for sending the telegram to the bus, to control blind up/down. Telegrams:                      1 — Move down                      0 — Move up                      Obj.2 is the same as above.</p>					
1	Recall/storage scene No.	Page 1-{{Icon 1}}	1byte	C, T C,W,T	18.001 scene control
<p>The communication object is used to send the telegram of scene recall or storage. The highest bit 1 is the scene storage, and the highest bit 0 is the scene recall.                      Short press the icon to recall scene, and long press is optional whether to storage scene.                      The flag is C,W,T when enable the object with status feedback; the flag is C,T, when disable.</p>					
49	Locking object	Page 1-{{...}}	1bit	C,W	1.003 enable
<p>The communication object is used to lock/unlock icon function. Except for status display function, apply to the functions as follow. Telegrams:                      1 — Unlock                      0 — Lock                      The name in parentheses changes with the parameter "Description for page function". If description is empty, display "Page x-..." by default.                      The same below.</p>					

Table 6.3.1 "Multifunction (Lighting/Blind/Scene/Value send)" communication object table

## Description of Communication Object

### 6.3.2 “Room temperature control” Communication Object

When the work mode is “Master”, the read requests of external sensor (with separate enable parameter, the same below), fan speed and fan automatic, the window and the presence are sent to the bus after voltage recovery, as well as send the status of power on/off, actual temperature (combined), current setpoint temperature, heating/cooling, operation mode.

When the work mode is “Single”, the read requests of external sensor, fan speed and fan automatic, the window and the presence are sent to the bus after voltage recovery, as well as the status of actual temperature (combined).

When the work mode is “Slave”, send the status requests of these functions after voltage recovery: power on/off, the external sensor, current setpoint temperature, heating/cooling control mode, operation mode, fan speed and fan automatic operation.

Number	Name	Object Function	Description	Group Address	Length	C	R	W	T	U	Data Type	Priority
246	Page 6-...	External temperature sensor			2 bytes	C	-	W	T	U	temperature (°C)	Low
247	Page 6-...	Base temperature setpoint, status			2 bytes	C	-	W	-	U	temperature (°C)	Low
248	Page 6-...	Heating/Cooling mode, status			1 bit	C	-	W	-	U	cooling/heating	Low
249	Page 6-...	Comfort mode, status			1 bit	C	-	W	-	U	enable	Low
250	Page 6-...	Standby mode, status			1 bit	C	-	W	-	U	enable	Low
251	Page 6-...	Economy mode, status			1 bit	C	-	W	-	U	enable	Low
252	Page 6-...	Frost/Heat protection mode, status			1 bit	C	-	W	-	U	enable	Low
253	Page 6-...	Fan speed low, status			1 bit	C	-	W	T	U	switch	Low
254	Page 6-...	Fan speed medium, status			1 bit	C	-	W	T	U	switch	Low
255	Page 6-...	Fan speed high, status			1 bit	C	-	W	T	U	switch	Low
256	Page 6-...	Fan speed off, status			1 bit	C	-	W	T	U	switch	Low
257	Page 6-...	Fan Automatic operation, status			1 bit	C	-	W	T	U	enable	Low
258	Page 6-...	Current setpoint adjustment			2 bytes	C	R	-	T	-	temperature (°C)	Low
259	Page 6-...	Heating/Cooling mode			1 bit	C	R	-	T	-	cooling/heating	Low
260	Page 6-...	Comfort mode			1 bit	C	R	-	T	-	enable	Low
261	Page 6-...	Standby mode			1 bit	C	R	-	T	-	enable	Low
262	Page 6-...	Economy mode			1 bit	C	R	-	T	-	enable	Low
263	Page 6-...	Frost/Heat protection mode			1 bit	C	R	-	T	-	enable	Low
264	Page 6-...	Heating control value			1 bit	C	-	-	T	-	switch	Low
265	Page 6-...	Cooling control value			1 bit	C	-	-	T	-	switch	Low
266	Page 6-...	Fan speed low			1 bit	C	-	-	T	-	switch	Low
267	Page 6-...	Fan speed medium			1 bit	C	-	-	T	-	switch	Low
268	Page 6-...	Fan speed high			1 bit	C	-	-	T	-	switch	Low
269	Page 6-...	Fan speed off			1 bit	C	-	-	T	-	switch	Low
270	Page 6-...	Fan Automatic operation			1 bit	C	R	-	T	-	enable	Low
271	Page 6-...	Power on/off			1 bit	C	R	-	T	-	switch	Low
272	Page 6-...	Current base setpoint temperature			2 bytes	C	-	-	T	-	temperature (°C)	Low
273	Page 6-...	Actual temperature			2 bytes	C	R	-	T	-	temperature (°C)	Low
274	Page 6-...	Power on/off, status			1 bit	C	-	W	-	U	switch	Low
275	Page 6-...	Operation mode, status			1 byte	C	-	W	-	U	HVAC mode	Low
276	Page 6-...	Operation mode			1 byte	C	R	-	T	-	HVAC mode	Low
277	Page 6-...	Fan speed, status			1 byte	C	-	W	T	U	percentage (0..100%)	Low
278	Page 6-...	Fan speed			1 byte	C	R	-	T	-	percentage (0..100%)	Low
279	Page 6-...	Window contact			1 bit	C	-	W	T	U	window/door	Low
280	Page 6-...	Presence detector			1 bit	C	-	W	T	U	occupancy	Low
294	Page 6-...	Locking object			1 bit	C	-	W	-	-	enable	Low

Fig. 6.3.2 “Room temperature control” communication object

No.	Object function	Name	Data - Type	Flag	DPT
246	External temperature sensor	Page 6-{{...}}	2byte	C,W,T,U	9.001 temperature(°C)
The communication object is used to receive the temperature value detected by the temperature sensor of the device form the bus. Range: -50~99.9°C					
247	Current temperature setpoint Base temperature setpoint	Page 6-{{...}}	2byte	C,W,U	9.001 temperature (°C)
247	Current temperature setpoint, status	Page 6-{{...}}	2byte	C,W,T,U	9.001 temperature (°C)
When the work mode is “Master”, the flag is C,W,U: “Current temperature setpoint” is visible when operation mode is not enabled, and under absolute adjustment. Used to modify the base value of the set temperature when operation mode is not enabled; and to modify set temperature value of current room operation mode when absolute adjustment. “Base temperature setpoint” is visible only when relative adjustment, used to modify the base value of the set temperature, that is, the temperature setting value of the comfort mode, and the setting temperature of the standby mode and the economy mode changes according to the relative change. In the protection mode, only the temperature setting value of the protection mode is modified. When the work mode is “Slave”, the flag is C,W,T,U, only “Current temperature setpoint, status” is visible, used to receive the status of current setpoint temperature from the controller via the bus. While “Single”, no these objects.					

## Description of Communication Object

No.	Object function	Name	Data - Type	Flag	DPT
248	Heating/Cooling mode	Page 6-{{...}}	1bit	C,W,U	1.100 cooling/heating
248	Heating/Cooling mode, status	Page 6-{{...}}	1bit	C,W,T,U	1.100 cooling/heating
<p>When the work mode is "Master" or "Single", the flag is C,W,U, "Heating/Cooling mode" is visible, used to receive telegram from bus to control heating/cooling mode.</p> <p>When the work mode is "Slave", the flag is C,W,T,U, "Heating/Cooling mode, status" is visible, used to receive the status of heating/cooling mode, which is fed back from the controller on the bus.</p> <p>The screen will update the icon display according to the received telegram value. Telegrams:                      1 — Heating                      0 — Cooling</p>					
249	Comfort mode	Page 6-{{...}}	1bit	C,W,U	1.003 enable
250	Standby mode	Page 6-{{...}}	1bit	C,W,U	1.003 enable
251	Economy mode	Page 6-{{...}}	1bit	C,W,U	1.003 enable
252	Frost/heat protection mode	Page 6-{{...}}	1bit	C,W,U	1.003 enable
275	Operation mode	Page 6-{{...}}	1byte	C,W,U	20.102 HVAC mode
275	Operation mode, status	Page 6-{{...}}	1byte	C,W,T,U	20.102 HVAC mode
<p>When 1bit, used to receive telegrams from bus to control each operation mode:                      Object 249 — Comfort mode                      Object 250 — Standby mode                      Object 251 — Economy mode                      Object 252 — Protection mode</p> <p>When the object receives the telegram "1", the corresponding mode is activated and the display status of the mode on the screen will also be updated to the corresponding mode.</p> <p>When the work mode is "Single" or "Slave", these four objects are not visible..</p> <p>When 1 byte, Object 275 is visible:</p> <p>When the work mode is "Master" or "Single", the flag is C,W,U, "Operation mode" is visible, used to receive telegram from bus to control operation mode.</p> <p>When the work mode is "Slave", the flag is C,W,T,U, "Operation mode, status" is visible, used to receive the status of operation mode, which is fed back from the controller on the bus.</p> <p>Telegram value: 1-Comfort, 2-Standby, 3-Economy, 4-Protection, other reserved.</p>					
253	Fan speed low, status	Page 6-{{...}}	1bit	C,W,T,U	1.001 switch
254	Fan speed medium, status	Page 6-{{...}}	1bit	C,W,T,U	1.001 switch
255	Fan speed high, status	Page 6-{{...}}	1bit	C,W,T,U	1.001 switch
256	Fan speed off, status	Page 6-{{...}}	1bit	C,W,T,U	1.001 switch
277	Fan speed, status	Page 6-{{...}}	1byte	C,W,T,U	5.001 percentage (0..100%)
<p>Fan speed can be received the status feedback via four 1bit objects (253, 254, 255, 256) or one 1byte object (Fan speed, status).</p> <p>When 1bit:                      Object 253 — Low fan speed                      Object 254 — Medium fan speed                      Object 255 — High fan speed                      Object 256 — Fan speed off, the object is visible when parameter "1 bit object for fan speed off" is enabled.</p> <p>When the work mode is "Single" or "Slave", these four objects are not visible.</p> <p>When the object receives telegram "1", the corresponding fan speed is activated, and the display status of the fan speed on the screen is also updated to the corresponding fan speed. If 1bit off is not enabled, the telegram value of all fan speed must be 0; if it is enabled, telegram 0 is meaningless.</p> <p>When 1 byte: the fan speed status value is defined by the parameter. When the object 277 receives the specified value, the display status of fan speed on the screen is updated to the corresponding fan speed.</p>					
257	Fan Automatic operation, status	Page 6-{{...}}	1bit	C,W,T,U	1.003 enable
<p>The object is visible when fan speed auto is enabled, used to receive status feedback from automatic fan speed control. Telegram value:                      1 — Automatic                      0 — Cancel automatic</p>					
258	Current setpoint adjustment, status	Page 6-{{...}}	2byte	C,R,T	9.001 temperature(°C)
258	Current setpoint adjustment	Page 6-{{...}}	2byte	C,T	9.001 temperature(°C)
<p>When the work mode is "Master", the flag is C,R,T, "Current setpoint adjustment, status" is visible, used to feed back status of current setpoint temperature to the bus.</p> <p>When the work mode is "Slave", the flag is C,T, "Current setpoint adjustment" is visible, used to send the current setpoint temperature to bus.</p> <p>While "Single", this object is not visible.</p>					

## Description of Communication Object

No.	Object function	Name	Data - Type	Flag	DPT
259	Heating/Cooling mode, status	Page 6-{{...}}	1bit	C,T C,R,T	1.100 cooling/heating
<p>When the work mode is "Master", the flag is C,R,T, while "Single" is C,T, the communication object is visible when control mode is "Heating and Cooling" is not selected. Used to send telegrams from switching cooling and heating functions to the bus. Telegram value:</p> <p>1 — Heating 0 — Cooling</p> <p>While "Slave", this object is not visible.</p>					
260	Comfort mode, status	Page 6-{{...}}	1bit	C,R,T	1.003enable
261	Standby mode, status	Page 6-{{...}}	1bit	C,R,T	1.003enable
262	Economy mode, status	Page 6-{{...}}	1bit	C,R,T	1.003enable
263	Frost/Heat protection mode, status	Page 6-{{...}}	1bit	C,R,T	1.003enable
276	Operation mode, status	Page 6-{{...}}	1byte	C,T C,R,T	20.102 DPT_HVAC Mode
276	Operation mode	Page 6-{{...}}	1byte	C,T	20.102 DPT_HVAC Mode
<p>When 1bit: Switch to the corresponding mode, and the object of the corresponding mode sends the telegram "1" to the bus. When the work mode is "Single" or "Slave", these four objects are not visible.</p> <p>When 1byte, Object 276 is visible: When the work mode is "Master", the flag is C,R,T, while "Single" is C,T, "Operation mode, status" is visible, used to feed back status of operation mode to the bus. When the work mode is "Slave", the flag is C,T, "Operation mode" is visible, used to send the operation mode of controller to bus. Telegrams: 1: Comfort mode; 2: Standby mode; 3: Economy mode; 4: Protection mode; other reserved.</p>					
264	Heating control value Heating/cooling control value	Page 6-{{...}}	1byte 1bit	C,T	5.001 percentage(0..100%) 1.001 switch
265	Cooling control value	Page 6-{{...}}	1byte 1bit	C,T	5.001 percentage(0..100%) 1.001 switch
<p>These two communication objects are used to send control value of heating or cooling function to control the switch of RTC valve and adjust the indoor temperature.</p> <p>Send 1bit telegram value (Switch on/off - 2-point control): on/off Send 1bit telegram value (Switch PWM - PI control): on/off Send 1byte telegram value (Continuous control - PI control): 0...100%</p> <p>When the work mode is "Slave", these two objects are not visible..</p>					
266	Fan speed low	Page 6-{{...}}	1bit	C,T	1.001 switch
267	Fan speed medium	Page 6-{{...}}	1bit	C,T	1.001 switch
268	Fan speed high	Page 6-{{...}}	1bit	C,T	1.001 switch
269	Fan speed off	Page 6-{{...}}	1bit	C,T	1.001 switch
278	Fan speed	Page 6-{{...}}	1byte	C,T C,R,T	5.001 percentage(0..100%)
<p>Send control telegrams of the fan speed to the bus via four 1bit objects (266, 267, 268, 269) or one 1byte object (Fan speed)</p> <p>When 1bit: Object 266 — Low fan speed Object 267 — Medium fan speed Object 268 — High fan speed Object 269 — Fan speed off, the object is visible when parameter "1 bit object for fan speed off" is enabled.</p> <p>When the work mode is "Single" or "Slave", these four objects are not visible.</p> <p>The corresponding fan speed is activated on the screen, and the corresponding object sends telegram "1" to the bus When 1bit-off object is not enable, all objects send telegrams "0" when switch to fan speed off (The situation apply to connect with fan actuator of GVS); When 1bit-off object is enable, only 1bit-off object send telegram "1" (The situation apply to connect with fan actuator of other manufacturers).</p> <p>When 1 byte: the corresponding telegram value of each fan speed is defined by the parameter. Activate the corresponding fan speed on the screen, and object 278 sends the corresponding telegram value of the fan speed to the bus.</p> <p>When the work mode is "Master", the flag is C,R,T; when "Single" or "Slave", the flag is C,T</p>					
270	Fan Automatic operation	Page 6-{{...}}	1bit	C,T C,R,T	1.003 enable
<p>The object is visible when fan speed auto is enabled, used to send the automatic control telegram of the fan speed to the bus. Telegram value:</p> <p>1 — Automatic 0 — Cancel automatic</p> <p>When the work mode is "Master", the flag is C,R,T; when "Single" or "Slave", the flag is C,T</p>					

## Description of Communication Object

No.	Object function	Name	Data - Type	Flag	DPT
271	Power on/off, status	Page 6-{{...}}	1bit	C,R,T	1.001 switch
271	Power on/off	Page 6-{{...}}	1bit	C,T	1.001 switch
<p>When the work mode is "Master", the flag is C,R,T, "Power on/off, status" is visible, used to feed back status of power on/off to the bus.                      When the work mode is "Slave", the flag is C,T, "Power on/off" is visible, used to send the power on/off telegram to bus, to control the controller on the KNX bus.                      While "Single", this object is not visible.</p>					
272	Current base temperature setpoint, status	Page 6-{{...}}	2byte	C,T	9.001 temperature
<p>When the work mode is "Master", the communication object is visible when relative adjustment is selected. Used to send the current base setpoint temperature value to the bus.                      When the work mode is "Single" or "Slave", this object is not visible.</p>					
273	Actual temperature	Page 6-{{...}}	1bit	C,R,T	9.001 temperature
<p>The communication object is visible when temperature reference is selected "Internal sensor combine with External sensor", used to send the actual temperature after the combination to the bus.</p>					
274	Power on/off	Page 6-{{...}}	1bit	C,W,U	1.001 switch
274	Power on/off, status	Page 6-{{...}}	1bit	C,W,T,U	1.001 switch
<p>When the work mode is "Master", the flag is C,W,U, "Power on/off" is visible, used to receive telegram from bus to control power on/off.                      When the work mode is "Slave", the flag is C,W,T,U, "Power on/off, status" is visible, used to receive the status of power on/off, which is fed back from the controller on the bus.                      While "Single", this object is not visible.                      The screen will update the icon display according to the received telegram value, telegrams:                      1 — On                      0 — Off</p>					
279	Window contact	Page 6-{{...}}	1bit	C,W,T,U	1.019 Window/door
<p>The communication object is used to receive the switch status of window contact. Telegrams:                      1 — Open window                      0 — Close window                      When the work mode is "Slave", this object is not visible.</p>					
280	Presence detector	Page 6-{{...}}	1bit	C,W,T,U	1.018 occupancy
<p>The communication object is used to receive the room occupancy status from presence detector. Telegrams:                      1 — Some one                      0 — No one                      When the work mode is "Slave", this object is not visible.</p>					
294	Locking object	Page 6-{{...}}	1bit	C,W	1.003 enable
<p>The communication object is used to lock/unlock icon function, and can receive telegrams form bus during locking. Telegrams:                      1 — Lock                      0 — Unlock                      This object is suitable for air conditioner, audio control, colour temperature, floor heating and ventilation system, except for air quality and energy display function.                      The following sections will not be repeated.</p>					

Table 6.3.2 "Room temperature control" communication object table



## Description of Communication Object

### 6.3.3 “Air conditioner”Communication Object

When status read request is enabled, system needs to return to the status as before voltage failure when voltage recovery, and need to send these status requests when restarted: power on/off, mode, fan speed, setpoint temperature, external temperature sensor, vanes swing and vanes positions (related function is enabled).

Number	Name	Object Function	Description	Group Address	Length	C	R	W	T	U	Data Type	Priority
246	Page 6-...	External temperature sensor			2 bytes	C	-	W	T	U	temperature (°C)	Low
247	Page 6-...	Power on/off			1 bit	C	-	-	T	-	switch	Low
248	Page 6-...	Power on/off, status			1 bit	C	-	W	T	U	switch	Low
249	Page 6-...	Control mode			1 byte	C	-	-	T	-	HVAC control mode	Low
250	Page 6-...	Control mode, status			1 byte	C	-	W	T	U	HVAC control mode	Low
254	Page 6-...	Fan speed			1 byte	C	-	-	T	-	percentage (0..100%)	Low
255	Page 6-...	Fan speed, status			1 byte	C	-	W	T	U	percentage (0..100%)	Low
257	Page 6-...	Vanes swing (1-swing,0-stop)			1 bit	C	-	-	T	-	start/stop	Low
258	Page 6-...	Vanes swing (1-swing,0-stop), status			1 bit	C	-	W	T	U	start/stop	Low
259	Page 6-...	Vanes position 1.5			1 byte	C	-	-	T	-	counter pulses (0..255)	Low
260	Page 6-...	Vanes position 1.5, status			1 byte	C	-	W	T	U	counter pulses (0..255)	Low
261	Page 6-...	Current setpoint adjustment			2 bytes	C	-	-	T	-	temperature (°C)	Low
262	Page 6-...	Current temperature setpoint, status			2 bytes	C	-	W	T	U	temperature (°C)	Low
294	Page 6-...	Locking object			1 bit	C	-	W	-	-	enable	Low

Fig. 6.3.3 “Air conditioner” communication object

No.	Object function	Name	Data - Type	Flag	DPT
246	External temperature sensor	Page 6-{{...}}	2byte	C,W,T,U	9.001 temperature(°C)
The communication object is used to receive the temperature value sent by the indoor temperature sensor on the bus and displaying the indoor temperature on the screen.					
247	Power on/off	Page 6-{{...}}	1bit	C,T	1.001 switch
The communication object is used to send the power on/off telegram of air conditioner to KNX bus.					
248	Power on/off, status	Page 6-{{...}}	1bit	C,W,T,U	1.001 switch
The communication object is used to receive the power on/off telegram of air conditioner from the bus, and feedback to screen display. Telegrams: 1 — On 0 — Off					
249	Control mode	Page 6-{{...}}	1byte	C,T	20.105 HAVC control mode
The communication object is used to send control telegram of each air conditioner mode to the bus. Different telegram means different control mode. 0-Auto, 1- Heating, 3-Cooling, 9-Fan, 14-Dehumidity, other reserved..					
250	Control mode, status	Page 6-{{...}}	1byte	C,W,T,U	20.105 HAVC control mode
The communication object is used to receive the current control mode from the bus, and feedback to screen display. Different telegram means different control mode. 0-Auto, 1- Heating, 3-Cooling, 9-Fan, 14-Dehumidity, other reserved.					
254	Fan speed	Page 6-{{...}}	1byte	C,T	5.001 percentage 5.100 fan stage
The communication object is used to send control telegram of each fan speed to the bus. Telegram value is determined by parameter setting datatype.					
255	Fan speed, status	Page 6-{{...}}	1byte	C,W,T,U	5.001 percentage 5.100 fan stage
The communication object is used to receive the current fan speed from the bus, and feedback to screen display. Telegram value is determined by parameter setting datatype.					
257	Vanes swing (1-swing,0-stop)	Page 6-{{...}}	1bit	C,W,T,U	1.010 start/stop
The communication object is visible when vanes swing function is enabled. Used to send telegram for controlling vanes swing to the bus. Telegrams:					
258	Vanes swing (1-swing,0-stop), status	Page 6-{{...}}	1bit	C,W,T,U	1.010 start/stop
The communication object is visible when vanes swing function is enabled. Used to receive the vanes swing status from the bus. Telegrams: 1 — Swing 0 — Stop					
259	Vanes position 1..5	Page 6-{{...}}	1byte	C,T	5.010 counter pulses(0..255)
The communication object is visible when vanes position function is enabled. Used to send telegrams for fixing vanes position 1..5.					
260	Vanes position 1..5, status	Page 6-{{...}}	1byte	C,W,T,U	5.010 counter pulses(0..255)
The communication object is visible when vanes position function is enabled. Used to receive the status feedback of the fixed vanes direction position 1..5.					

## Description of Communication Object

No.	Object function	Name	Data - Type	Flag	DPT
261	Current setpoint adjustment	Page 6-{{...}}	1byte 2byte	C,T	5.010 counter pulses(0..255) 9.001 temperature(°C)
The communication object is used to adjust the setpoint temperature and send the telegram value to the bus. <b>Note: the object type is set by parameters, 2byte is suitable for KNX standard, 1byte is KNX non-standard, usually suitable for some customized control classes, the telegram value is the actual temperature value, such as 17 °C telegram value is 17 (decimal number).</b>					
262	Current temperature setpoint, status	Page 6-{{...}}	1byte	C,W,T,U	5.010 counter pulses(0..255) 9.001 temperature(°C)
The communication object is used to receive the current setpoint temperature from bus, and feed back to screen display.					

Table 6.3.3 “Air conditioner” communication object table

### 6.3.4 “Audio control”Communication Object

When status read request is enabled, and power on/off is disabled, system needs to return to the status as before voltage failure when voltage recovery, and need to send these status requests when restarted: play status, mute, volume percent, play mode, track name, album name, artist name (related function is enabled); When power on/off is enabled, the sending requests are the same with the disabled, but note that status of power on/off is no need to send.

Number	Name	Object Function	Description	Group Address	Length	C	R	W	T	U	Data Type	Priority
246	Page 6-...	Power on/off			1 bit	C	-	-	T	-	switch	Low
247	Page 6-...	Play=1/Pause=0			1 bit	C	-	-	T	-	start/stop	Low
248	Page 6-...	Next track=1/Previous track=0			1 bit	C	-	-	T	-	step	Low
249	Page 6-...	Absolute volume			1 byte	C	-	-	T	-	percentage (0..100%)	Low
250	Page 6-...	Play mode			1 byte	C	-	-	T	-	counter pulses (0..255)	Low
251	Page 6-...	Play mode, status			1 byte	C	-	W	T	U	counter pulses (0..255)	Low
252	Page 6-...	Volume+=1/Volume-=0			1 bit	C	-	-	T	-	step	Low
253	Page 6-...	Power on/off, status			1 bit	C	-	W	T	U	switch	Low
254	Page 6-...	Play=1/Pause=0, status			1 bit	C	-	W	T	U	start/stop	Low
255	Page 6-...	Volume, status			1 byte	C	-	W	T	U	percentage (0..100%)	Low
256	Page 6-...	Mute			1 bit	C	-	-	T	-	enable	Low
257	Page 6-...	Mute, status			1 bit	C	-	W	T	U	enable	Low
258	Page 6-...	Track name			14 bytes	C	-	W	T	U	Character String (ISO 8859-1)	Low
259	Page 6-...	Album name			14 bytes	C	-	W	T	U	Character String (ISO 8859-1)	Low
260	Page 6-...	Artist name			14 bytes	C	-	W	T	U	Character String (ISO 8859-1)	Low
261	Page 6-...	Play			1 bit	C	-	-	T	-	enable	Low
262	Page 6-...	Pause			1 bit	C	-	-	T	-	enable	Low
263	Page 6-...	Play, status			1 bit	C	-	W	T	U	enable	Low
264	Page 6-...	Pause, status			1 bit	C	-	W	T	U	enable	Low
265	Page 6-...	Next track			1 bit	C	-	-	T	-	enable	Low
266	Page 6-...	Previous track			1 bit	C	-	-	T	-	enable	Low
294	Page 6-...	Locking object			1 bit	C	-	W	-	-	enable	Low

Fig. 6.3.4 “Audio control” communication object

No.	Object function	Name	Data - Type	Flag	DPT
246	Power on/off	Page 6-{{...}}	1bit	C,T	1.001 switch
The communication object is visible when power on/off is enabled. Used to send the telegram to the bus. Telegrams: 1 — On 0 — Off					
247	Play=1/Pause=0	Page 6-{{...}}	1bit	C,T	1.010 start/stop
The communication object is visible when control play/pause with one object. Used to play/stop the music in the audio module. Telegrams: 1 — Play music 0 — Pause playing music					
248	Next track=1/Previous track=0	Page 6-{{...}}	1bit	C,T	1.007 step
The communication object is visible when control next track/previous track with one object. Used to switch the playing song of the audio module, to switch the previous song/the next song. Telegrams: 1 — Play the next song 0 — Play the previous song					
249	Absolute volume	Page 6-{{...}}	1bit	C,T	5.001 percentage 5.004 percentage
When 1byte, the communication object is used to adjust volume of the audio module. Telegrams value is according to different object types: 0..100 / 0..255					



## Description of Communication Object

No.	Object function	Name	Data - Type	Flag	DPT
250	<b>Play mode</b>	<b>Page 6-{{...}}</b>	<b>1byte</b>	<b>C,T</b>	<b>5.010 counter pluses(0..255)</b>
The communication object is used to send control telegram of the audio module play mode, different mode telegrams are preset by parameters.					
251	<b>Play mode, status</b>	<b>Page 6-{{...}}</b>	<b>1byte</b>	<b>C,W,T,U</b>	<b>5.010 counter pluses(0..255)</b>
The communication object is used to receive the status feedback of play mode in the audio module, the receiving telegrams should be preset by parameters before the display status on the screen can be updated.					
252	<b>Volume+=1/Volume-=0</b>	<b>Page 6-{{...}}</b>	<b>1bit</b>	<b>C,T</b>	<b>1.007 step</b>
When 1bit, the communication object is used to adjust volume of the audio module. Telegrams: 1 — Increase volume 0 — Decrease volume					
253	<b>Power on/off, status</b>	<b>Page 6-{{...}}</b>	<b>1bit</b>	<b>C,W,T,U</b>	<b>1.001 switch</b>
The communication object is visible when power on/off is enabled. Used to receive the status feedback of on/off in audio module from bus.					
254	<b>Play=1/Pause=0, status</b>	<b>Page 6-{{...}}</b>	<b>1bit</b>	<b>C,W,T,U</b>	<b>1.010 start/stop</b>
The communication object is used to receive the status feedback of play/pause in audio module from bus, and feed back to screen display.					
255	<b>Volume, status</b>	<b>Page 6-{{...}}</b>	<b>1byte</b>	<b>C,W,T,U</b>	<b>5.001 percentage 5.004 percentage</b>
When 1byte, the communication object is used to receive the volume status in audio module, and feed back to screen display. Telegrams value is according to different object types: 0..100 / 0..255					
256	<b>Mute</b>	<b>Page 6-{{...}}</b>	<b>1bit</b>	<b>C,T</b>	<b>1.003 enable</b>
The communication object is visible when mute is enabled. Used to control mute of audio module via the screen. Telegrams: 1 — Mute 0 — Cancel mute					
257	<b>Mute, status</b>	<b>Page 6-{{...}}</b>	<b>1bit</b>	<b>C,W,T,U</b>	<b>1.003 enable</b>
The communication object is visible when mute is enabled. Used to receive the mute status of the audio module from the bus, and feed back to screen display.					
258	<b>Track name</b>	<b>Page 6-{{...}}</b>	<b>14byte</b>	<b>C,W,T,U</b>	<b>16.001 character string (ISO 8859-1)</b>
The communication object is used to receive the track name via the bus, and display on the screen.					
259	<b>Album name</b>	<b>Page 6-{{...}}</b>	<b>14byte</b>	<b>C,W,T,U</b>	<b>16.001 character string (ISO 8859-1)</b>
The communication object is used to receive the album name via the bus, and display on the screen..					
260	<b>Artist name</b>	<b>Page 6-{{...}}</b>	<b>14byte</b>	<b>C,W,T,U</b>	<b>16.001 character string (ISO 8859-1)</b>
The communication object is used to receive the artist name via the bus, and display on the screen.					
261	<b>Play</b>	<b>Page 6-{{...}}</b>	<b>1bit</b>	<b>C,T</b>	<b>1.003 enable</b>
The communication object is visible when control play/pause with two separate objects. Used to play the music in the audio module. Telegram 1 is to play, 0 is meaningless.					
262	<b>Pause</b>	<b>Page 6-{{...}}</b>	<b>1bit</b>	<b>C,T</b>	<b>1.003 enable</b>
The communication object is visible when control play/pause with two separate objects. Used to stop the music in the audio module. Telegram 1 is to stop, 0 is meaningless.					
263	<b>Play, status</b>	<b>Page 6-{{...}}</b>	<b>1bit</b>	<b>C,W,T,U</b>	<b>1.003 enable</b>
The communication object is visible when control play/pause with two separate objects. Used to receive the status feedback of play in audio module from bus, and feed back to screen display. Telegram 1 is to play, 0 is meaningless.					
264	<b>Pause, status</b>	<b>Page 6-{{...}}</b>	<b>1bit</b>	<b>C,W,T,U</b>	<b>1.003 enable</b>
The communication object is visible when control play/pause with two separate objects. Used to receive the status feedback of pause in audio module from bus, and feed back to screen display. Telegram 1 is to stop, 0 is meaningless.					
265	<b>Next track</b>	<b>Page 6-{{...}}</b>	<b>1bit</b>	<b>C,T</b>	<b>1.003 enable</b>
The communication object is visible when control next track/previous track with two separate objects. Used to switch the playing song of the audio module, to switch the next song. Telegram 1 is to stop, 0 is meaningless..					
266	<b>Previous track</b>	<b>Page 6-{{...}}</b>	<b>1bit</b>	<b>C,T</b>	<b>1.003 enable</b>
The communication object is visible when control next track/previous track with two separate objects. Used to switch the playing song of the audio module, to switch the previous song. Telegram 1 is to stop, 0 is meaningless.					

Table 6.3.4 "Audio control" communication object table

## Description of Communication Object

### 6.3.5 “Colour and colour temperature control”Communication Object

When status read request is enabled, and need to send status requests of all objects when restarted.

Note: the switch status is not sent read request when Brightness+Colour Temperature is selected.

Number	Name	Object Function	Description	Group Address	Length	C	R	W	T	U	Data Type	Priority
246	Page 6-...	Red dimming value			1 byte	C	-	-	T	-	percentage (0..100%)	Low
247	Page 6-...	Green dimming value			1 byte	C	-	-	T	-	percentage (0..100%)	Low
248	Page 6-...	Blue dimming value			1 byte	C	-	-	T	-	percentage (0..100%)	Low
252	Page 6-...	Red brightness, status			1 byte	C	-	W	T	U	percentage (0..100%)	Low
253	Page 6-...	Green brightness, status			1 byte	C	-	W	T	U	percentage (0..100%)	Low
254	Page 6-...	Blue brightness, status			1 byte	C	-	W	T	U	percentage (0..100%)	Low
258	Page 6-...	Switch			1 bit	C	-	-	T	-	switch	Low
259	Page 6-...	Switch, status			1 bit	C	-	W	T	U	switch	Low
294	Page 6-...	Locking object			1 bit	C	-	W	-	-	enable	Low
<b>RGB_3x1byte</b>												
246	Page 6-...	RGB dimming value			3 bytes	C	-	-	T	-	RGB value 3x(0..255)	Low
252	Page 6-...	RGB brightness, status			3 bytes	C	-	W	T	U	RGB value 3x(0..255)	Low
258	Page 6-...	Switch			1 bit	C	-	-	T	-	switch	Low
259	Page 6-...	Switch, status			1 bit	C	-	W	T	U	switch	Low
294	Page 6-...	Locking object			1 bit	C	-	W	-	-	enable	Low
<b>RGB_1x3byte</b>												
246	Page 6-...	Red dimming value			1 byte	C	-	-	T	-	percentage (0..100%)	Low
247	Page 6-...	Green dimming value			1 byte	C	-	-	T	-	percentage (0..100%)	Low
248	Page 6-...	Blue dimming value			1 byte	C	-	-	T	-	percentage (0..100%)	Low
249	Page 6-...	White dimming value			1 byte	C	-	-	T	-	percentage (0..100%)	Low
252	Page 6-...	Red brightness, status			1 byte	C	-	W	T	U	percentage (0..100%)	Low
253	Page 6-...	Green brightness, status			1 byte	C	-	W	T	U	percentage (0..100%)	Low
254	Page 6-...	Blue brightness, status			1 byte	C	-	W	T	U	percentage (0..100%)	Low
255	Page 6-...	White brightness, status			1 byte	C	-	W	T	U	percentage (0..100%)	Low
258	Page 6-...	Switch			1 bit	C	-	-	T	-	switch	Low
259	Page 6-...	Switch, status			1 bit	C	-	W	T	U	switch	Low
294	Page 6-...	Locking object			1 bit	C	-	W	-	-	enable	Low
<b>RGBW_4x1byte</b>												
246	Page 6-...	RGBW dimming value			6 bytes	C	-	-	T	-	RGBW value 4x(0..100%)	Low
252	Page 6-...	RGBW brightness, status			6 bytes	C	-	W	T	U	RGBW value 4x(0..100%)	Low
258	Page 6-...	Switch			1 bit	C	-	-	T	-	switch	Low
259	Page 6-...	Switch, status			1 bit	C	-	W	T	U	switch	Low
294	Page 6-...	Locking object			1 bit	C	-	W	-	-	enable	Low
<b>RGBW_1x6byte</b>												
246	Page 6-...	RGB dimming value			3 bytes	C	-	-	T	-	RGB value 3x(0..255)	Low
249	Page 6-...	White dimming value			1 byte	C	-	-	T	-	percentage (0..100%)	Low
252	Page 6-...	RGB brightness, status			3 bytes	C	-	W	T	U	RGB value 3x(0..255)	Low
255	Page 6-...	White brightness, status			1 byte	C	-	W	T	U	percentage (0..100%)	Low
258	Page 6-...	Switch			1 bit	C	-	-	T	-	switch	Low
259	Page 6-...	Switch, status			1 bit	C	-	W	T	U	switch	Low
294	Page 6-...	Locking object			1 bit	C	-	W	-	-	enable	Low
<b>RGBW_3byte+1byte</b>												
246	Page 6-...	RGB dimming value			3 bytes	C	-	-	T	-	RGB value 3x(0..255)	Low
250	Page 6-...	Brightness value			1 byte	C	-	-	T	-	percentage (0..100%)	Low
251	Page 6-...	Colour temperature value			2 bytes	C	-	-	T	-	absolute colour temperature (K)	Low
252	Page 6-...	RGB brightness, status			3 bytes	C	-	W	T	U	RGB value 3x(0..255)	Low
256	Page 6-...	Brightness, status			1 byte	C	-	W	T	U	percentage (0..100%)	Low
257	Page 6-...	Colour temperature, status			2 bytes	C	-	W	T	U	absolute colour temperature (K)	Low
258	Page 6-...	Switch			1 bit	C	-	-	T	-	switch	Low
259	Page 6-...	Switch, status			1 bit	C	-	W	T	U	switch	Low
294	Page 6-...	Locking object			1 bit	C	-	W	-	-	enable	Low
<b>RGBCW_1x3byte_Normal</b>												

## Description of Communication Object

246	Page 6-...	RGB dimming value	3 bytes	C - - T -	RGB value 3x(0..255)	Low
249	Page 6-...	Warm white brightness	1 byte	C - - T -	percentage (0..100%)	Low
250	Page 6-...	Cool white brightness	1 byte	C - - T -	percentage (0..100%)	Low
252	Page 6-...	RGB brightness, status	3 bytes	C - W T U	RGB value 3x(0..255)	Low
256	Page 6-...	Brightness, status	1 byte	C - W T U	percentage (0..100%)	Low
257	Page 6-...	Colour temperature, status	2 bytes	C - W T U	absolute colour temperature (K)	Low
258	Page 6-...	Switch	1 bit	C - - T -	switch	Low
259	Page 6-...	Switch, status	1 bit	C - W T U	switch	Low
294	Page 6-...	Locking object	1 bit	C - W - -	enable	Low
<b>RGBCW_1x3byte_Directly(.) &amp; Brightness+Colour Temperature</b>						
246	Page 6-...	RGB dimming value	3 bytes	C - - T -	RGB value 3x(0..255)	Low
249	Page 6-...	Warm white brightness	1 byte	C - - T -	percentage (0..100%)	Low
250	Page 6-...	Cool white brightness	1 byte	C - - T -	percentage (0..100%)	Low
252	Page 6-...	RGB brightness, status	3 bytes	C - W T U	RGB value 3x(0..255)	Low
255	Page 6-...	Warm white brightness, status	1 byte	C - W T U	percentage (0..100%)	Low
256	Page 6-...	Cool white brightness, status	1 byte	C - W T U	percentage (0..100%)	Low
258	Page 6-...	Switch	1 bit	C - - T -	switch	Low
259	Page 6-...	Switch, status	1 bit	C - W T U	switch	Low
294	Page 6-...	Locking object	1 bit	C - W - -	enable	Low
<b>RGBCW_1x3byte_Directly(.) &amp; Warm/Cool white brightness</b>						

Fig. 6.3.5 “Colour and colour temperature control” communication object

No.	Object function	Name	Data - Type	Flag	DPT																		
246	RGB dimming value	Page 6-{{...}}	3byte	C,T	232.600 RGB value 3x(0..255)																		
252	RGB brightness, status	Page 6-{{...}}	3byte	C,W,T,U	232.600 RGB value 3x(0..255)																		
<p>These two communication objects are visible when 1x3byte for the RGB object type or 3byte+1byte for the RGBW object type is selected. Apply to control brightness of multi-colour lamp, and also support colour temperature adjustment.</p> <p>Obj.246: used for sending brightness value of RGB three-colour lamp to the bus.</p> <p>Obj.252: used for receiving brightness value of RGB three-colour lamp from bus.</p> <p>3-Byte Code for RGB Dimming Object Data Type: U8 U8 U8, as follows:</p> <table border="1" style="margin-left: 20px;"> <tr> <td style="text-align: center;">3MSB</td> <td style="text-align: center;">2</td> <td style="text-align: center;">1LSB</td> </tr> <tr> <td style="text-align: center;">R</td> <td style="text-align: center;">G</td> <td style="text-align: center;">B</td> </tr> <tr> <td style="text-align: center;">UUUUUUUU</td> <td style="text-align: center;">UUUUUUUU</td> <td style="text-align: center;">UUUUUUUU</td> </tr> </table> <p>R: red dimming value; G: green dimming value; B: blue dimming value</p>						3MSB	2	1LSB	R	G	B	UUUUUUUU	UUUUUUUU	UUUUUUUU									
3MSB	2	1LSB																					
R	G	B																					
UUUUUUUU	UUUUUUUU	UUUUUUUU																					
246	RGBW dimming value	Page 6-{{...}}	6byte	C,T	251.600 RGB value 4x(0..255)																		
252	RGBW brightness, status	Page 6-{{...}}	6byte	C,W,T,U	251.600 DPT_Colour_RGBW																		
<p>These two communication objects are visible when 1x6byte for the RGBW object type is selected. Apply to control brightness of multi-colour lamp.</p> <p>Obj.246: used for sending brightness value of RGBW four-colour lamp to the bus.</p> <p>Obj.252: used for receiving brightness value of RGBW four-colour lamp from bus.</p> <p>Encoding of the data type of the 6-byte RGBW dimming object: U8 U8 U8 U8 R8 R4 B4, as follows</p> <table border="1" style="margin-left: 20px;"> <tr> <td style="text-align: center;">6MSB</td> <td style="text-align: center;">5</td> <td style="text-align: center;">4</td> <td style="text-align: center;">3</td> <td style="text-align: center;">2</td> <td style="text-align: center;">1LSB</td> </tr> <tr> <td style="text-align: center;">R</td> <td style="text-align: center;">G</td> <td style="text-align: center;">B</td> <td style="text-align: center;">W</td> <td style="text-align: center;">Reserve</td> <td style="text-align: center;">r r r r mR mG mB mW</td> </tr> <tr> <td style="text-align: center;">UUUUUUUU</td> <td style="text-align: center;">UUUUUUUU</td> <td style="text-align: center;">UUUUUUUU</td> <td style="text-align: center;">UUUUUUUU</td> <td style="text-align: center;">00000000</td> <td style="text-align: center;">0000BBBB</td> </tr> </table> <p>R : red dimming value; G: green dimming value; B: blue dimming value; W: white dimming value;                      mR : determines whether the red dimming value is valid, 0 = invalid, 1 = valid;                      mG : determines whether the green dimming value is valid, 0 = invalid, 1 = valid;                      mB : determines whether the blue dimming value is valid, 0 = invalid, 1 = valid; mW: Determines whether the white dimming value is valid, 0 = invalid, 1 = valid.</p>						6MSB	5	4	3	2	1LSB	R	G	B	W	Reserve	r r r r mR mG mB mW	UUUUUUUU	UUUUUUUU	UUUUUUUU	UUUUUUUU	00000000	0000BBBB
6MSB	5	4	3	2	1LSB																		
R	G	B	W	Reserve	r r r r mR mG mB mW																		
UUUUUUUU	UUUUUUUU	UUUUUUUU	UUUUUUUU	00000000	0000BBBB																		
246	Red dimming value	Page 6-{{...}}	1byte	C,T	5.001 percentage(0..100%)																		
252	Red dimming value, status	Page 6-{{...}}	1byte	C,W,T,U	5.001 percentage(0..100%)																		
<p>These two communication objects are visible when 3x1byte for the RGB object type or 4x1byte for the RGBW object type is selected. Apply to control brightness of multi-colour lamp, and also support colour temperature adjustment. Telegrams: 0...100%</p> <p>Obj.246: used for sending brightness value of the control R (red) channel to the bus.</p> <p>Obj.252: used for receiving brightness value of the control R (red) channel from bus.</p>																							

## Description of Communication Object

No.	Object function	Name	Data - Type	Flag	DPT
247	Green dimming value	Page 6-{{...}}	1byte	C,T	5.001 percentage (0..100%)
253	Green dimming value, status	Page 6-{{...}}	1byte	C,W,T,U	5.001 percentage (0..100%)
These two communication objects are visible when 3x1byte for the RGB object type or 4x1byte for the RGBW object type is selected. Apply to control brightness of multi-colour lamp, and also support colour temperature adjustment. Telegrams: 0...100% Obj.247: used for sending brightness value of the control G (green) channel to the bus. Obj.253: used for receiving brightness value of the control G (green) channel from bus.					
248	Blue dimming value	Page 6-{{...}}	1byte	C,T	5.001 percentage (0..100%)
254	Blue dimming value, status	Page 6-{{...}}	1byte	C,W,T,U	5.001 percentage (0..100%)
These two communication objects are visible when 3x1byte for the RGB object type or 4x1byte for the RGBW object type is selected. Apply to control brightness of multi-colour lamp, and also support colour temperature adjustment. Telegrams: 0...100% Obj.248: used for sending brightness value of the control B (blue) channel to the bus. Obj.254: used for receiving brightness value of the control B (blue) channel from bus.					
249	White dimming value	Page 6-{{...}}	1byte	C,T	5.001 percentage (0..100%)
255	White dimming value, status	Page 6-{{...}}	1byte	C,W,T,U	5.001 percentage (0..100%)
These two communication objects are visible when 4x1byte or 3byte+1byte for the RGBW object type is selected. Apply to control brightness of multi-colour lamp. Telegrams: 0...100% Obj.249: used for sending brightness value of the control W (white) channel to the bus. Obj.255: used for receiving brightness value of the control W (white) channel from bus.					
249	Warm white brightness	Page 6-{{...}}	1byte	C,T	5.001 percentage (0..100%)
255	Warm white brightness, status	Page 6-{{...}}	1byte	C,W,T,U	5.001 percentage (0..100%)
Under the directly control, these two communication objects apply to warm white brightness control of two-colour lamp. Telegrams: 0...100% Obj.249: under directly control, used for sending the warm white dimming telegram to the bus, that is, sending the warm white brightness value. Obj.255: under directly control & (Warm/Cool white brightness), used for receiving the warm white brightness status responded from the dimming actuator.					
250	Brightness	Page 6-{{...}}	1byte	C,T	5.001 percentage (0..100%)
256	Brightness, status	Page 6-{{...}}	1byte	C,W,T,U	5.001 percentage (0..100%)
These two communication objects apply to colour temperature adjustment of monochrome lamp/two-colour lamp. Telegrams: 0...100% Obj.250: under normal control, used for sending the dimming telegram of the colour temperature to the bus, that is, sending the brightness value. Obj.256: under normal or directly control & (Brightness+Colour Temperature), used for receiving the brightness status responded from the dimming actuator.					
250	Cool white brightness	Page 6-{{...}}	1byte	C,T	5.001 percentage (0..100%)
256	Cool white brightness, status	Page 6-{{...}}	1byte	C,W,T,U	5.001 percentage (0..100%)
Under the directly control, these two communication objects apply to cool white brightness control of two-colour lamp. Telegrams: 0...100% Obj.250: under directly control, used for sending the cool white dimming telegram to the bus, that is, sending the cool cool brightness value. Obj.256: under directly control & (Warm/Cool white brightness), used for receiving the cool white brightness status responded from the dimming actuator.					
251	Colour temperature value	Page 6-{{...}}	2byte	C,T	7.600 absolute colour temperature (K)
257	Colour temperature, status	Page 6-{{...}}	1byte	C,W,T,U	7.600 absolute colour temperature (K)
These two communication objects apply to colour temperature adjustment of monochrome lamp/two-colour lamp. Telegrams: 2000...7000 K Obj.251: under normal control, used for sending the control telegram of the colour temperature to the bus. Obj.257: under normal or directly control & (Brightness+Colour Temperature), used for receiving the control telegram of the colour temperature from bus.					
258	Switch	Page 6-{{...}}	1bit	C,T	1.001 switch
259	Switch, status	Page 6-{{...}}	1bit	C,W,T,U	1.001 switch
These two communication objects apply to control switch the lamp. Telegrams: 0 — Off 1 — On Obj. 258: used for sending on/off telegram to the bus, to control the lamp on/off. Obj. 259: used for receiving On/Off status responded from other bus devices.					

Table 6.3.5 "Colour and colour temperature control" communication object table



## Description of Communication Object

### 6.3.6 “Air Quality display”Communication Object

Send status requests of all objects when restarted.

Number	Name	Object Function	Description	Group Address	Length	C	R	W	T	U	Data Type	Priority
246	Page 6-Items 1	Temperature value			2 bytes	C	-	W	T	U	temperature (°C)	Low
246	Page 6-Items 1	Humidity value			2 bytes	C	-	W	T	U	humidity (%)	Low
246	Page 6-Items 1	PM2.5 value			2 bytes	C	-	W	T	U	pulses	Low
246	Page 6-Items 1	PM10 value			2 bytes	C	-	W	T	U	pulses	Low
246	Page 6-Items 1	CO2 value			2 bytes	C	-	W	T	U	parts/million (ppm)	Low
246	Page 6-Items 1	VOC value			2 bytes	C	-	W	T	U	pulses	Low
246	Page 6-Items 1	AQI value			2 bytes	C	-	W	T	U	pulses	Low
246	Page 6-Items 1	Brightness value			2 bytes	C	-	W	T	U	lux (Lux)	Low
246	Page 6-Items 1	Wind speed			2 bytes	C	-	W	T	U	speed (m/s)	Low
246	Page 6-Items 1	Rain state			1 bit	C	-	W	T	U	switch	Low
247	Page 6-Items 2	Temperature value			2 bytes	C	-	W	T	U	temperature (°C)	Low
248	Page 6-Items 3	Temperature value			2 bytes	C	-	W	T	U	temperature (°C)	Low
249	Page 6-Items 4	Temperature value			2 bytes	C	-	W	T	U	temperature (°C)	Low

Fig. 6.3.6 “Air Quality display” communication object

No.	Object function	Name	Data - Type	Flag	DPT
246	Temperature	Page 6-{{Items 1}}	2Byte	C,W,T,U	9.001 temperature(°C)
The communication object is used to receive temperature measurements sent from the temperature sensor on the bus. Range: -40~40°C The name in parentheses changes with the parameter “Description”. If description is empty, display “Page x-Items y” by default. The same below.					
246	Humidity	Page 6-{{Items 1}}	2byte	C,W,T,U	9.007 humidity (%)
The communication object is used to receive a humidity measurement sent from a humidity sensor on a bus. Range: 0~100%					
246	PM2.5	Page 6-{{Items 1}}	2byte	C,W,T,U	7.001 pulse 9.030 concentration (µg/m³)
The communication object is used to receive the input of PM2.5 value and get the corresponding value from the bus to be updated to display in µg/m³. Range: 0~999µg/m³, the data type of the object is set by the parameter.					
246	PM10	Page 6-{{Items 1}}	2byte	C,W,T,U	7.001 pulse 9.030 concentration(µg/m³)
This communication object is used to receive the input of pm10 value, get the corresponding value update to display from bus, the unit is µg/m³. Range: 0~999µg/m³, the data type of the object is set by the parameter.					
246	CO2	Page 6-{{Items 1}}	2byte	C,W,T,U	7.001 pulse 9.008 parts/million(ppm)
The communication object is used to receive the input of the CO2 value and get the corresponding value from the bus to be updated to the display in ppm. Range: 0~4000ppm					
246	VOC	Page 6-{{Items 1}}	2byte	C,W,T,U	7.001 pulse 9.030 concentration(µg/m³) 9.008 parts/million(ppm)
The communication object is used to receive the input of the VOC value and get the corresponding value from the bus to be updated to the display in mg/m³ or ppm. Range: 0~9.99mg/m³ or 0~4000ppm, the data type of the object is set by the parameter. When the object data type is selected for 7.001 pulses, the percentile ratio is reduced on the basis of the DPT 7.001 pulses, for example, the receiving value is 5000 µg/m³ and the actual display value is 5.00mg/m³.					
246	AQI	Page 6-{{Items 1}}	2byte	C,W,T,U	7.001 pulses
The communication object is used to receive the input of AQI value and update the corresponding value from the bus to display. Range: 0~500					
246	Brightness	Page 6-{{Items 1}}	2byte	C,W,T,U	7.013 brightness(lux) 9.004 lux(Lux)
The communication object is used to receive the input of the brightness value and get the corresponding value from the bus to be updated to the display in lux. Range: 0~50000lux, the data type of the object is set by the parameter.					
246	Wind speed	Page 6-{{Items 1}}	2byte	C,W,T,U	9.005 speed 9.028 wind speed
The communication object is used to receive the input of the wind speed value and get the corresponding value from the bus to be updated to the display in m/s or km/h. Range: 0~50m/s or 0~183km/h					

## Description of Communication Object

No.	Object function	Name	Data - Type	Flag	DPT
246	Rain state	Page 6-{{Items 1}}	1bit	C,W,T,U	1.001 switch
The communication object is used to receive the input of the rain state and get the corresponding value from the bus to be updated to the display. Telegrams: 1 — Rain 0 — No rain					

Table 6.3.6 "Air Quality display" communication object table

### 6.3.7 "Floor heating" Communication Object

When the work mode is "Master", the read requests of external sensor is sent to the bus after voltage recovery, as well as send the status of power on/off, actual temperature (combined), current setpoint temperature.

When the work mode is "Single", the read requests of external sensor is sent to the bus after voltage recovery, as well as send the status of the actual temperature (combined).

When the work mode is "Slave", send the status requests of these functions after voltage recovery: power on/off, the external sensor, current setpoint temperature.

Number	Name	Object Function	Description	Group Address	Length	C	R	W	T	U	Data Type	Priority
246	Page 6-...	External temperature sensor			2 bytes	C	-	W	T	U	temperature (°C)	Low
247	Page 6-...	Power on/off			1 bit	C	R	-	T	-	switch	Low
248	Page 6-...	Heating on/off			1 bit	C	-	-	T	-	switch	Low
249	Page 6-...	Current temperature setpoint, status			2 bytes	C	-	W	-	U	temperature (°C)	Low
250	Page 6-...	Power on/off, status			1 bit	C	-	W	-	U	switch	Low
251	Page 6-...	Scene			1 byte	C	-	W	-	-	scene control	Low
258	Page 6-...	Current setpoint adjustment			2 bytes	C	R	-	T	-	temperature (°C)	Low
273	Page 6-...	Actual temperature			2 bytes	C	R	-	T	-	temperature (°C)	Low
294	Page 6-...	Locking object			1 bit	C	-	W	-	-	enable	Low

Fig. 6.3.7 "Floor heating" communication object

No.	Object function	Name	Data - Type	Flag	DPT
246	External temperature sensor	Page 6-{{...}}	2byte	C,W,T,U	9.001 temperature (°C)
The communication object is visible when the temperature reference selects the external sensor and is used to receive the temperature measurement value sent from the temperature sensor on the bus. Range: -50~99.8°C					
247	Power on/off, status	Page 6-{{...}}	1bit	C,R,T	1.001 switch
247	Power on/off	Page 6-{{...}}	1bit	C,T	1.001 switch
When the work mode is "Master", the flag is C,R,T, "Power on/off, status" is visible, used to feed back status of power on/off to the bus. When the work mode is "Slave", the flag is C,T, "Power on/off" is visible, used to send the power on/off telegram to bus, to control the controller on the KNX bus. While "Single", this object is not visible. <b>Note: When off, all icons in the interface can not to operate except for the timer and on/off icons</b>					
248	Heating on/off	Page 6-{{...}}	1bit	C,T	1.001 switch
248	Heating control value	Page 6-{{...}}	1byte	C,T	5.001 percentage (0..100%)
These communication objects are used to send the control value of floor heating to control the switch of floor heating valve. Send telegram value (Heating on/off - 2-point control): on/off Send telegram value (Heating PWM - PI control): on/off Send telegram value (Heating continuous control - PI control): 0. 100% When the work mode is "Slave", these objects are not visible.					
249	Current temperature setpoint	Page 6-{{...}}	2byte	C,W,U	9.001 temperature (°C)
249	Current temperature setpoint, status	Page 6-{{...}}	2byte	C,W,T,U	9.001 temperature (°C)
When the work mode is "Master", the flag is C,W,U, "Current temperature setpoint" is visible, used to modify the current setpoint temperature. When the work mode is "Slave", the flag is C,W,T,U, "Current temperature setpoint, status" is visible, used to receive the status of current setpoint temperature, which is fed back from the controller on the bus. While "Single", this object is not visible.					
250	Power on/off	Page 6-{{...}}	1bit	C,W,U	1.001 switch
250	Power on/off, status	Page 6-{{...}}	1bit	C,W,T,U	1.001 switch
When the work mode is "Master", the flag is C,W,U, "Power on/off" is visible, used to receive telegram from bus to control power on/off. When the work mode is "Slave", the flag is C,W,T,U, "Power on/off, status" is visible, used to receive the status of power on/off, which is fed back from the controller on the bus. While "Single", this object is not visible. Telegrams: 1 — On 0 — NOff					

## Description of Communication Object

No.	Object function	Name	Data - Type	Flag	DPT
251	Scene	Page 6-{{...}}	1byte	C,W	18.001 scene control
The communication object is visible when scene function enabled. Used to recall/storage scene via bus. When the work mode is "Slave", this object is not visible.					
258	Current setpoint adjustment, status	Page 6-{{...}}	2byte	C,R,T	9.001 temperature
258	Current setpoint adjustment	Page 6-{{...}}	2byte	C,T	9.001 temperature
When the work mode is "Master", the flag is C,R,T, "Current setpoint adjustment, status" is visible, used to feed back status of current setpoint temperature to the bus. When the work mode is "Slave", the flag is C,T, "Current setpoint adjustment" is visible, used to send the current setpoint temperature to bus. While "Single", this object is not visible.					
273	Actual temperature	Page 6-{{...}}	2byte	C,R,T	9.001 temperature
The communication object is visible when the temperature reference selects the external sensor and is used to transmit the actual temperature value detected by the combination temperature sensor of the device to the bus.					

Table 6.3.7 "Floor heating" communication object table

### 6.3.8 "Ventilation System" Communication Object

It is no need to send status requests when ventilation system restarted. If auto fan speed is enabled, send the status read requests of PM2.5 and CO2 when restarted.

Number	Name	Object Function	Description	Group Address	Length	C	R	W	T	U	Data Type	Priority
246	Page 6-...	Power on/off			1 bit	C	-	-	T	-	switch	Low
247	Page 6-...	Power on/off, status			1 bit	C	-	W	T	U	switch	Low
248	Page 6-...	En./Dis. Heat recovery			1 bit	C	-	W	-	-	enable	Low
249	Page 6-...	Heat recovery			1 bit	C	-	-	T	-	switch	Low
250	Page 6-...	Filter timer reset			1 bit	C	-	W	-	-	reset	Low
251	Page 6-...	Filter timer counter			2 bytes	C	-	W	T	U	time (h)	Low
252	Page 6-...	Filter alarm			1 bit	C	-	-	T	-	alarm	Low
253	Page 6-...	Fan Speed No.1 1Bit			1 bit	C	-	W	T	U	switch	Low
254	Page 6-...	Fan Speed No.2 1Bit			1 bit	C	-	W	T	U	switch	Low
255	Page 6-...	Fan Speed No.3 1Bit			1 bit	C	-	W	T	U	switch	Low
256	Page 6-...	Automatic function			1 bit	C	-	W	T	U	enable	Low
257	Page 6-...	CO2 value			2 bytes	C	-	W	T	U	parts/million (ppm)	Low
258	Page 6-...	PM2.5 value			2 bytes	C	-	W	T	U	pulses	Low
259	Page 6-...	Scene			1 byte	C	-	W	-	-	scene control	Low
260	Page 6-...	Fan speed			1 byte	C	-	-	T	-	percentage (0..100%)	Low
261	Page 6-...	Fan speed, status			1 byte	C	-	W	T	U	percentage (0..100%)	Low
262	Page 6-...	Heat recovery, status			1 bit	C	-	W	T	U	switch	Low
294	Page 6-...	Locking object			1 bit	C	-	W	-	-	enable	Low

Fig. 6.3.8 "Ventilation system" communication object

No.	Object function	Name	Data - Type	Flag	DPT
246	Power on/off	Page 6-{{...}}	1bit	C,T	1.001 switch
The communication object is used to send the power on/off telegram of ventilation to KNX bus. Telegrams: 1 — On 0 — Off					
247	Power on/off, status	Page 6-{{...}}	1bit	C,W,T,U	1.001 switch
The communication object is used to receive the power on/off telegram of ventilation from the bus.					
248	En./Dis. Heat Recovery	Page 6-{{...}}	1bit	C,W	1.003 enable
The communication object is used to disable/enable the heat recovery function of ventilation system. The disabled/enabled telegram value is specifically defined by the parameter. When disabled, the heat recovery is turned off and cannot be controlled.					
249	Heat Recovery	Page 6-{{...}}	1bit	C,W,T,U	1.001 switch
The communication object is used to send the control command of on/off ventilation system heat recovery, and the status feedback value can also be received. Telegram values 1 — On 0 — Off					
250	Filter time reset	Page 6-{{...}}	1bit	C,W	1.015 reset
The communication object is used to reset the filter time, and after the filter is reset, the filter time is used to start counting again. Telegram value: 1 — Reset					



## Description of Communication Object

No.	Object function	Name	Data - Type	Flag	DPT
251	Filter time counter	Page 6-{{...}}	2byte	C,W,T,U	7.007 time(h)
The communication object is used to count the length of the filter. When the count value changes, it can be sent to the bus, and the time can also be modified by the bus. The unit of filter time counter is in hours.					
252	Filter alarm	Page 6-{{...}}	1bit	C,T	1.005 alarm
When the filter is used for longer than the set value, the communication object issues an alarm to remind the user to replace the filter. Telegram value: 1 — Alarm					
253	Fan Speed No.1 1Bit	Page 6-{{...}}	1bit	C,W,T,U	1.001 switch
254	Fan Speed No.2 1Bit	Page 6-{{...}}	1bit	C,W,T,U	1.001 switch
255	Fan Speed No.3 1Bit	Page 6-{{...}}	1bit	C,W,T,U	1.001 switch
The three communication objects are visible when fan speed type is selected "1bit", the fan speed is controlled by the three objects at the same time, and the specific telegram value corresponding to each fan speed is defined by the parameters. Status feedback can be received, but the feedback value also needs to correspond to the parameter definition value to update the display on the screen.					
256	Automatic function	Page 6-{{...}}	1bit	C,W,T,U	1.003 enable
The communication object is used to enable the automatic operation of ventilation system. After the device is reset or programmed, the automatic operation is not enabled by default. Turn off the machine and manually adjust the fan speed. The scene can exit the automatic operation. The disabled/enabled telegram value is specifically defined by the parameter.					
257	CO2	Page 6-{{...}}	2byte	C,W,T,U	9.008 parts/million (ppm) 7.001 pulses
The communication object is used to receive the input of the CO2 value and get the corresponding value from the bus to be updated to the display in ppm. Range: 0~400ppm If the control value of the automatic operation is CO2, the ventilation system can be set to automatically adjust the fan speed according to the concentration of CO2. The data type of the object is set by the parameter.					
258	PM2.5	Page 6-{{...}}	2byte	C,W,T,U	9.030 concentration (µg/m³) 7.001 pulses
The communication object is used to receive the input of PM2.5 value and get the corresponding value from the bus to be updated to display in µg/m³. Range: 0~999 µg/m³ If the control value of the automatic operation is PM2.5, the ventilation system can be set to automatically adjust the fan speed according to the concentration of PM2.5. The data type of the object is set by the parameter.					
259	Scene	Page 6-{{...}}	1byte	C,W	18.001 scene control
The communication object is visible when scene function enabled. Used to recall/storage scene via bus.					
260	Fan speed	Page 6-{{...}}	1byte	C,T	5.010 percentage (0..100%)
The communication object is visible when the fan speed type is "1byte" and is used to send a telegram to the bus to control the fan speed. The specific telegram value corresponding to each fan speed is defined by the parameters.					
261	Fan speed, status	Page 6-{{...}}	1byte	C,W,T,U	5.010 percentage(0..100%)
The communication object is visible when the fan speed type is "1byte" and is used to receive the status feedback of the fan speed. The specific telegram value corresponding to each fan speed is defined by the parameter.					
262	Heat recovery, status	Page 6-{{...}}	1byte	C,W,T,U	1.001 switch
The communication object is used to receive the status feedback of heat recovery, and is updated to screen display.					

Table 6.3.8 "Ventilation System" communication object table

### 6.3.9 "Energy Metering display" Communication Object

Number	Name	Object Function	Description	Group Address	Length	C	R	W	T	U	Data Type	Priority
246	Page 6-Energy Meter 1	Current in mA (DPT 7.012)			2 bytes	C	-	W	T	U	current (mA)	Low
247	Page 6-Energy Meter 2	Current in mA (DPT 9.021)			2 bytes	C	-	W	T	U	current (mA)	Low
248	Page 6-Energy Meter 3	Current in A (DPT 14.019)			4 bytes	C	-	W	T	U	electric current (A)	Low
249	Page 6-Energy Meter 4	Voltage in mV (DPT 9.020)			2 bytes	C	-	W	T	U	voltage (mV)	Low
250	Page 6-Energy Meter 5	Voltage in V (DPT 14.027)			4 bytes	C	-	W	T	U	electric potential (V)	Low
251	Page 6-Energy Meter 6	Power in W (DPT 14.056)			4 bytes	C	-	W	T	U	power (W)	Low
252	Page 6-Energy Meter 7	Power in kW (DPT 9.024)			2 bytes	C	-	W	T	U	power (kW)	Low
253	Page 6-Energy Meter 8	Active energy in Wh (DPT 13.010)			4 bytes	C	-	W	T	U	active energy (Wh)	Low
295	Page 7-Energy Meter 1	Active energy in kWh (DPT 13.013)			4 bytes	C	-	W	T	U	active energy (kWh)	Low

Fig. 6.3.9 "Energy Metering display" communication object

## Description of Communication Object

No.	Object function	Name	Data - Type	Flag	DPT
246	Current in mA(DPT 7.012)	Page 6-{{Energy Meter 1}}	2byte	C,W,T,U	7.012 current (mA)
The communication object is used to receive the current value from the bus and update it to the screen display. The display range is 0 ~ 65535 mA, and the resolution is 1 mA. The name in parentheses changes with the parameter "Description". If description is empty, display "Page x-Energy Meter y" by default. The same below.					
246	Current in mA(DPT 9.021)	Page 6-{{Energy Meter 1}}	2byte	C,W,T,U	9.021 current (mA)
The communication object is used to receive the current value from the bus and update it to the screen display. The display range is -670760~670760mA, and the resolution is 0.01mA.					
246	Current in A(DPT 14.019)	Page 6-{{Energy Meter 1}}	4byte	C,W,T,U	14.019 electric current (A)
The communication object is used to receive the current value from the bus and update it to the screen display. The display range is -99999999.9~99999999.9A, and the resolution is 0.1A.					
246	Voltage in mV(DPT 9.020)	Page 6-{{Energy Meter 1}}	2byte	C,W,T,U	9.020 voltage (mV)
The communication object is used to receive voltage values from the bus and update them to the screen display. The display range is -670760mV~670760mV, and the resolution is 0.01mV.					
246	Voltage in V(DPT 14.027)	Page 6-{{Energy Meter 1}}	4byte	C,W,T,U	14.027 electric potential (V)
The communication object is used to receive voltage values from the bus and update them to the screen display. The display range is: -99999999.9~99999999.9V, and the resolution is 0.1V.					
246	Power in W(DPT 14.056)	Page 6-{{Energy Meter 1}}	4byte	C,W,T,U	14.056 power (W)
The communication object is used to receive the power values from the bus and update them to the screen display. The display range is: -99999999.9 ~ 99999999.9W, and the resolution is 0.1W.					
246	Power in kW(DPT 9.024)	Page 6-{{Energy Meter 1}}	2byte	C,W,T,U	9.024 power (kW)
The communication object is used to receive the power values from the bus and update them to the screen display. The display range is: -670760~670760kW, and the resolution is 0.01kW.					
246	Active energy in Wh(DPT 13.010)	Page 6-{{Energy Meter 1}}	4byte	C,W,T,U	13.010 active energy (Wh)
The communication object is used to receive the electrical values from the bus and update them to the screen display. The display range is: -2147483648~2147483647Wh, and the resolution is 1Wh.					
246	Active energy in kWh(DPT 13.013)	Page 6-{{Energy Meter 1}}	4byte	C,W,T,U	13.013 active energy (kWh)
The communication object is used to receive the electrical values from the bus and update them to the screen display. The display range is: -2147483648~2147483647kWh, and the resolution is 1kWh.					

Table 6.3.9 "Energy Metering display" communication object table

### 6.4 "Internal temperature measurement" Communication Object

Number	Name	Object Function	Description	Group Address	Length	C	R	W	T	U	Data Type	Priority
912	Internal sensor	Actual temperature			2 bytes	C	R	-	T	-	temperature (°C)	Low
913	Internal sensor	Temp.correction(-10..10)K			2 bytes	C	-	W	-	-	temperature difference (K)	Low
914	Internal sensor	Temp.error report			1 bit	C	R	-	T	-	alarm	Low

Fig. 6.4 "Internal temperature measurement" communication object

No.	Object function	Name	Data - Type	Flag	DPT
912	Actual temperature	Internal sensor	2Bytes	C,R,T	9.001 temperature (°C)
The communication object is used for transmitting the temperature value detected by the built-in temperature sensor of the device to the bus. Range: -50~99.8°C					
913	Temp.correction(-10...10)K	Internal sensor	2Bytes	C,W	9.002 temperature difference
The communication object is used for correcting the temperature measurement value of the device built-in temperature sensor through the bus.					
914	Temp.error report	Internal sensor	1bit	C,R,T	1.005 alarm
The communication object is used to send the error report of the built-in temperature sensor, and the object value is defined according to the parameters.					

Table 6.4 "Internal temperature measurement" communication object table

## Description of Communication Object

### 6.5 “Human Centric Lighting(HCL)” Communication Object

Number	Name	Object Function	Description	Group Address	Length	C	R	W	T	U	Data Type	Priority
938	Human Centric Lighting(HCL)	Start HCL			1 bit	C	-	W	-	-	start/stop	Low
939	Human Centric Lighting(HCL)	HCL status			1 bit	C	R	-	T	-	state	Low
940	Human Centric Lighting(HCL)	Brightness value			1 byte	C	-	-	T	-	percentage (0..100%)	Low
941	Human Centric Lighting(HCL)	Colour temperature value			2 bytes	C	-	-	T	-	absolute colour temperature (K)	Low
942	Human Centric Lighting(HCL)	Warm white brightness			1 byte	C	-	-	T	-	percentage (0..100%)	Low
943	Human Centric Lighting(HCL)	Cool white brightness			1 byte	C	-	-	T	-	percentage (0..100%)	Low
944	Human Centric Lighting(HCL)	Switch control			1 bit	C	-	W	-	-	switch	Low
945	Human Centric Lighting(HCL)	Brightness control value			1 byte	C	-	W	-	-	percentage (0..100%)	Low
946	Human Centric Lighting(HCL)	Colour temperature control value			2 bytes	C	-	W	-	-	absolute colour temperature (K)	Low
947	Human Centric Lighting(HCL)	Warm white brightness control value			1 byte	C	-	W	-	-	percentage (0..100%)	Low
948	Human Centric Lighting(HCL)	Cool white brightness control value			1 byte	C	-	W	-	-	percentage (0..100%)	Low

Fig. 6.5 “Human Centric Lighting(HCL)” communication object

No.	Object function	Name	Data - Type	Flag	DPT
938	Start HCL	Human Centric Lighting(HCL)	1bit	C,W	1.010 start/stop
The communication object is used to start the setting of HCL. Telegrams: 1 — Start 0 — Stop					
939	HCL status	Human Centric Lighting(HCL)	1bit	C,R,T	1.011 state
The communication object is used to send the status telegram of HCL to bus.					
940	Brightness value	Human Centric Lighting(HCL)	1byte	C,T	5.001 percentage (0..100%)
945	Brightness control value	Human Centric Lighting(HCL)	1byte	C,W	5.001 percentage (0..100%)
These two parameters are visible when control brightness via HCL. Telegrams: 0...100% Obj.940: used for sending dimming telegrams to the bus, that is, sending the brightness value. Obj.945: used for receiving brightness status responded from bus.					
941	Colour temperature value	Human Centric Lighting(HCL)	2byte	C,T	7.600 absolute colour temperature
946	Colour temperature control value	Human Centric Lighting(HCL)	2byte	C,W	7.600 absolute colour temperature
These two communication objects apply to normal control of colour temperature adjustment. Telegrams: 2000...7000 K Obj.941: used for sending the control telegram of the colour temperature to the bus. Obj.946: used for receiving the control telegram of the colour temperature from bus.					
942	Warm white brightness	Human Centric Lighting(HCL)	1byte	C,T	5.001 percentage (0..100%)
947	Warm white brightness control value	Human Centric Lighting(HCL)	1byte	C,W	5.001 percentage (0..100%)
These two communication objects apply to the warm white brightness in directly control. Telegrams: 0...100% Obj.942: used for sending the warm white dimming telegram to the bus, that is, sending the warm white brightness value. Obj.947: used for receiving the warm white brightness status responded from bus.					
943	Cool white brightness	Human Centric Lighting(HCL)	1byte	C,T	5.001 percentage (0..100%)
948	Cool white brightness control value	Human Centric Lighting(HCL)	1byte	C,W	5.001 percentage (0..100%)
These two communication objects apply to the cool white brightness in directly control. Telegrams: 0...100% Obj.943: used for sending the cool white dimming telegram to the bus, that is, sending the cool brightness value. Obj.948: used for receiving the cool white brightness status responded from bus.					
944	Switch control	Human Centric Lighting(HCL)	1bit	C,W	1.001 switch
During HCL running, stop running HCL when receive the telegram of switch control OFF from bus, the communication object is to receive the telegram OFF. That is telegram 0 is stop, 1 is meaningless.					

Table 6.5 “Human Centric Lighting(HCL)” communication object table

## Description of Communication Object

### 6.6 “Weekly timer function” Communication Object

Number	Name	Object Function	Description	Group Address	Length	C	R	W	T	U	Data Type	Priority
736	Time 1	On/Off			1 bit	C	-	-	T	-	switch	Low
737	Time 1	Disable/Enable			1 bit	C	-	W	-	-	enable	Low
738	Time 2	1byte unsigned value			1 byte	C	-	-	T	-	counter pulses (0..255)	Low
739	Time 2	Disable/Enable			1 bit	C	-	W	-	-	enable	Low
740	Time 3	Scene control			1 byte	C	-	-	T	-	scene number	Low
741	Time 3	Disable/Enable			1 bit	C	-	W	-	-	enable	Low
742	Time 4	HVAC mode			1 byte	C	-	-	T	-	HVAC mode	Low
743	Time 4	Disable/Enable			1 bit	C	-	W	-	-	enable	Low
744	Time 5	2byte unsigned value			2 bytes	C	-	-	T	-	pulses	Low
745	Time 5	Disable/Enable			1 bit	C	-	W	-	-	enable	Low
746	Time 6	On/Off			1 bit	C	-	-	T	-	switch	Low
748	Time 7	Temperature value			2 bytes	C	-	-	T	-	temperature (°C)	Low
749	Time 7	Disable/Enable			1 bit	C	-	W	-	-	enable	Low

Fig. 6.6 “Weekly timer function” communication object

No.	Object function	Name	Data - Type	Flag	DPT
736	On/Off 1byte unsigned value HVAC mode Scene control 2byte unsigned value Temperature value	{{Time 1}}	1bit 1byte 2byte	C,T	1.001 switch 5.010 counter pulses(0..255) 20.102 HVAC mode 17.001 scene number 7.001 pulses 9.001 temperature
The communication object is used to send the preset telegram value of the time function to the bus, and the time function, default value and object type are set by the parameters. When the time is up, send the default telegram value to the bus. A total of 16 timing(x= 16) can be set . The name in parentheses changes with the parameter “Description for time function”. If description is empty, display “Time x” by default. The same below.					
737	Disable/Enable	{{Time 1}}	1bit	C,W	1.003 enable
The communication object is used to disable/enable time function x. The disable/enable telegram value is specifically defined by the parameter. When disable, time x function will be disable.					

Table 6.6 “Weekly timer function” communication object table

### 6.7 “Scene Group function” Communication Object

Number	Name	Object Function	Description	Group Address	Length	C	R	W	T	U	Data Type	Priority
775	Scene Group Function	Main scene call			1 byte	C	-	W	-	-	scene number	Low
776	1st Scene Group-Output 1	1bit value			1 bit	C	-	-	T	-	switch	Low
777	1st Scene Group-Output 2	1byte unsigned value			1 byte	C	-	-	T	-	counter pulses (0..255)	Low
778	1st Scene Group-Output 3	HVAC mode			1 byte	C	-	-	T	-	HVAC mode	Low
779	1st Scene Group-Output 4	2byte unsigned value			2 bytes	C	-	-	T	-	pulses	Low
780	1st Scene Group-Output 5	Temperature			2 bytes	C	-	-	T	-	temperature (°C)	Low
781	1st Scene Group-Output 6	1bit value			1 bit	C	-	-	T	-	switch	Low
782	1st Scene Group-Output 7	1bit value			1 bit	C	-	-	T	-	switch	Low
783	1st Scene Group-Output 8	1bit value			1 bit	C	-	-	T	-	switch	Low

Fig. 6.7 “Scene Group function” communication object

No.	Object function	Name	Data - Type	Flag	DPT
775	Main scene recall	Scene Group	1byte	C,W	17.001 scene number
This communication object triggers each output in the scene group to send a specific value to the bus by recalling the scene number. Telegram: 0.. 63					
776/.../783	1bit value 1byte unsigned value HVAC mode 2byte unsigned value Temperature	1st Scene Group-{{Output x}}	1bit 1byte 2byte	C,T	1.001 switch 5.010 counter pulses 20.102 HVAC mode 7.001 pulses 9.001 temperature
When a scene is recalled, the communication object is used to send the corresponding output value of the scene to the bus. If the output is not set to this scene, it will not be sent. A total of 8 scene groups can be set up, with 8 outputs per group. The name in parentheses changes with the parameter “Description for Output x function”. If description is empty, display “1st Scene Group-Output x” by default.					

Table 6.7 “Scene Group function” communication object table



## Description of Communication Object

### 6.8 “Logic function” Communication Object

#### 6.8.1 “AND/OR/XOR” Communication Object

Number	Name	Object Function	Description	Group Address	Length	C	R	W	T	U	Data Type	Priority
840	1st Logic	Input a			1 bit	C	-	W	T	U	boolean	Low
841	1st Logic	Input b			1 bit	C	-	W	T	U	boolean	Low
842	1st Logic	Input c			1 bit	C	-	W	T	U	boolean	Low
843	1st Logic	Input d			1 bit	C	-	W	T	U	boolean	Low
844	1st Logic	Input e			1 bit	C	-	W	T	U	boolean	Low
845	1st Logic	Input f			1 bit	C	-	W	T	U	boolean	Low
846	1st Logic	Input g			1 bit	C	-	W	T	U	boolean	Low
847	1st Logic	Input h			1 bit	C	-	W	T	U	boolean	Low
848	1st Logic	Logic result			1 bit	C	-	-	T	-	boolean	Low

Fig. 6.8.1 “Logic function\_AND/OR/XOR” communication object

No.	Object function	Name	Data - Type	Flag	DPT
840/.../847	Input x	{{1st Logic}}	1bit	C,W,T,U	1.002 boolean
The communication object is used to receive the value of logical input Input x. The name in parentheses changes with the parameter “Description for logic function”. If description is empty, display “1st Logic” by default. The same below.					
848	Logic result	{{1st Logic}}	1bit	C,T	1.002 boolean
The communication object is used to send the results of logical operation.					

Table 6.8.1 “Logic function\_AND/OR/XOR” communication object table

#### 6.8.2 “Gate forwarding” Communication Object

Number	Name	Object Function	Description	Group Address	Length	C	R	W	T	U	Data Type	Priority
840	1st Logic	Gate value select			1 byte	C	-	W	-	-	scene number	Low
841	1st Logic	Input A			1 bit	C	-	W	-	-	switch	Low
842	1st Logic	Input B			1 bit	C	-	W	-	-	switch	Low
843	1st Logic	Input C			1 bit	C	-	W	-	-	switch	Low
844	1st Logic	Input D			1 bit	C	-	W	-	-	switch	Low
845	1st Logic	Output A			1 bit	C	-	-	T	-	switch	Low
846	1st Logic	Output B			1 bit	C	-	-	T	-	switch	Low
847	1st Logic	Output C			1 bit	C	-	-	T	-	switch	Low
848	1st Logic	Output D			1 bit	C	-	-	T	-	switch	Low

Fig. 6.8.2 “Logic function\_Gate forwarding” communication object

No.	Object function	Name	Data - Type	Flag	DPT
840	Gate value select	{{1st Logic}}	1byte	C,W	17.001 scene number
The communication object is used to select the scene of logical gate forwarding.					
841/.../844	Input x	{{1st Logic}}	1bit 4bit 1byte	C,W	1.001 switch 3.007 dimming control 5.010 counter pulses(0..255)
The communication object is used to receive the value of the logic gate input Input x					
845/.../848	Output x	{{1st Logic}}	1bit 4bit 1byte	C,T	1.001 switch 3.007 dimming control 5.010 counter pulses(0..255)
The communication object is used to output the value forwarded by the logic gate. The output value is the same as the input value, but one input can be forwarded into one or more outputs, set by parameters.					

Table 6.8.2 “Logic function\_Gate forwarding” communication object table

## Description of Communication Object

### 6.8.3 “Threshold comparator” Communication Object

Number	Name	Object Function	Description	Group Address	Length	C	R	W	T	U	Data Type	Priority
840	1st Logic	Threshold value input			4 bit	C	-	W	-	U	dimming control	Low
840	1st Logic	Threshold value input			2 bytes	C	-	W	-	U	pulses	Low
840	1st Logic	Threshold value input			2 bytes	C	-	W	-	U	2-byte signed value	Low
840	1st Logic	Threshold value input			2 bytes	C	-	W	-	U	2-byte float value	Low
840	1st Logic	Threshold value input			4 bytes	C	-	W	-	U	counter pulses (unsigned)	Low
840	1st Logic	Threshold value input			2 bytes	C	-	W	-	U	temperature (°C)	Low
840	1st Logic	Threshold value input			2 bytes	C	-	W	-	U	humidity (%)	Low
840	1st Logic	Threshold value input			2 bytes	C	-	W	-	U	lux (Lux)	Low
840	1st Logic	Threshold value input			2 bytes	C	-	W	-	U	parts/million (ppm)	Low
848	1st Logic	Logic result			1 bit	C	-	-	T	-	boolean	Low

Fig. 6.8.3“Logic function\_Threshold comparator” communication object

No.	Object function	Name	Data - Type	Flag	DPT
840	Threshold value input	{{1st Logic}}	4bit 1byte 2byte 4byte	C,W, U	3.007 dimming 5.010 counter pulses 7.001 pulses 12.001 counter pulses 8.x signed value 9.x float value 9.001 temperature 9.007 humidity 9.004 lux
The communication object is used to input threshold value					
848	Logic result	{{1st Logic}}	1bit	C,T	1.002 boolean
The communication object is used to send the results of logical operation. That is, the value that should be sent after the object input threshold is compared with the setting threshold value.					

Table 6.8.3“ Logic function\_Threshold comparator” communication object table

### 6.8.4 “Format convert” Communication Object

Number	Name	Object Function	Description	Group Address	Length	C	R	W	T	U	Data Type	Priority
840	1st Logic	Input 1bit-bit0			1 bit	C	-	W	-	U	switch	Low
841	1st Logic	Input 1bit-bit1			1 bit	C	-	W	-	U	switch	Low
848	1st Logic	Output 2bit			2 bit	C	-	-	T	-	switch control	Low

“2x1bit --> 1x2bit”function: converts two 1bit values to a 2bit value, such as Input bit1=1, bit0=0--> Output 2bit=2

Number	Name	Object Function	Description	Group Address	Length	C	R	W	T	U	Data Type	Priority
840	1st Logic	Input 1bit-bit0			1 bit	C	-	W	-	U	switch	Low
841	1st Logic	Input 1bit-bit1			1 bit	C	-	W	-	U	switch	Low
842	1st Logic	Input 1bit-bit2			1 bit	C	-	W	-	U	switch	Low
843	1st Logic	Input 1bit-bit3			1 bit	C	-	W	-	U	switch	Low
844	1st Logic	Input 1bit-bit4			1 bit	C	-	W	-	U	switch	Low
845	1st Logic	Input 1bit-bit5			1 bit	C	-	W	-	U	switch	Low
846	1st Logic	Input 1bit-bit6			1 bit	C	-	W	-	U	switch	Low
847	1st Logic	Input 1bit-bit7			1 bit	C	-	W	-	U	switch	Low
848	1st Logic	Output 1byte			1 byte	C	-	-	T	-	counter pulses (0..255)	Low

“8x1bit --> 1x1byte”function: converts eight 1bit values to a 1byte value, such as Input bit2=1, bit1=1, bit0=1, other bits are 0--> Output 1byte=7

Number	Name	Object Function	Description	Group Address	Length	C	R	W	T	U	Data Type	Priority
840	1st Logic	Input 1byte			1 byte	C	-	W	-	U	counter pulses (0..255)	Low
848	1st Logic	Output 2byte			2 bytes	C	-	-	T	-	pulses	Low

“1x1byte --> 1x2byte”function: converts one 1byte values to a 2byte value, such as Input 1byte=125--> Output 2byte=125. Although the value remains the same, the data type of the value is different.

## Description of Communication Object

Number	Name	Object Function	Description	Group Address	Length	C	R	W	T	U	Data Type	Priority
840	1st Logic	Input 1byte-low			1 byte	C	-	W	-	U	counter pulses (0..255)	Low
841	1st Logic	Input 1byte-high			1 byte	C	-	W	-	U	counter pulses (0..255)	Low
848	1st Logic	Output 2byte			2 bytes	C	-	-	T	-	pulses	Low

“2x1byte --> 1x2byte”function: converts two 1byte values to a 2byte value, such as Input 1byte-low = 255 (\$FF), Input 1byte-high = 100 (\$64) --> Output 2byte = 25855 (\$64 FF)

Number	Name	Object Function	Description	Group Address	Length	C	R	W	T	U	Data Type	Priority
840	1st Logic	Input 2byte-low			2 bytes	C	-	W	-	U	pulses	Low
841	1st Logic	Input 2byte-high			2 bytes	C	-	W	-	U	pulses	Low
848	1st Logic	Output 4byte			4 bytes	C	-	-	T	-	counter pulses (unsigned)	Low

“2x2byte --> 1x4byte”function: converts two 2 byte values to a 4byte value, such as Input 2byte-low = 65530 (\$FF FA), Input 2byte-high = 32768 (\$80 00)--> Output 2byte = 2147549178 (\$80 00 FF FA)

Number	Name	Object Function	Description	Group Address	Length	C	R	W	T	U	Data Type	Priority
840	1st Logic	Input 1byte			1 byte	C	-	W	-	U	counter pulses (0..255)	Low
841	1st Logic	Output 1bit-bit0			1 bit	C	-	-	T	-	switch	Low
842	1st Logic	Output 1bit-bit1			1 bit	C	-	-	T	-	switch	Low
843	1st Logic	Output 1bit-bit2			1 bit	C	-	-	T	-	switch	Low
844	1st Logic	Output 1bit-bit3			1 bit	C	-	-	T	-	switch	Low
845	1st Logic	Output 1bit-bit4			1 bit	C	-	-	T	-	switch	Low
846	1st Logic	Output 1bit-bit5			1 bit	C	-	-	T	-	switch	Low
847	1st Logic	Output 1bit-bit6			1 bit	C	-	-	T	-	switch	Low
848	1st Logic	Output 1bit-bit7			1 bit	C	-	-	T	-	switch	Low

“1x1byte --> 8x1bit” function: converts one 1byte values to eight 1bit value, such as Input 1byte=200 --> Output bit0=0, bit1=0, bit2=0, bit3=1, bit4=0, bit5=0, bit6=1, bit7=1

Number	Name	Object Function	Description	Group Address	Length	C	R	W	T	U	Data Type	Priority
840	1st Logic	Input 2byte			2 bytes	C	-	W	-	U	pulses	Low
847	1st Logic	Output 1byte-low			1 byte	C	-	-	T	-	counter pulses (0..255)	Low
848	1st Logic	Output 1byte-high			1 byte	C	-	-	T	-	counter pulses (0..255)	Low

“1x2byte --> 2x1byte”function: converts one 2byte values to two 1byte value, such as Input 2byte = 55500 (\$D8 CC) --> Output 1byte-low = 204 (\$CC), Output 1byte-high =216 (\$D8)

Number	Name	Object Function	Description	Group Address	Length	C	R	W	T	U	Data Type	Priority
840	1st Logic	Input 4byte			4 bytes	C	-	W	-	U	counter pulses (unsigned)	Low
847	1st Logic	Output 2byte-low			2 bytes	C	-	-	T	-	pulses	Low
848	1st Logic	Output 2byte-high			2 bytes	C	-	-	T	-	pulses	Low

“1x4byte --> 2x2byte”function: converts one 4byte values to two 2byte value, such as Input 4byte = 78009500 (\$04 A6 54 9C) --> Output 2byte-low = 21660 (\$54 9C), Output 2byte-high =1190 (\$04 A6)

Number	Name	Object Function	Description	Group Address	Length	C	R	W	T	U	Data Type	Priority
840	1st Logic	Input 3byte			3 bytes	C	-	W	-	U	RGB value 3x(0..255)	Low
846	1st Logic	Output 1byte-low			1 byte	C	-	-	T	-	counter pulses (0..255)	Low
847	1st Logic	Output 1byte-middle			1 byte	C	-	-	T	-	counter pulses (0..255)	Low
848	1st Logic	Output 1byte-high			1 byte	C	-	-	T	-	counter pulses (0..255)	Low

“1x3byte --> 3x1byte”function: converts one 3byte values to three 1byte value, such as Input 3byte = \$78 64 C8--> Output 1byte-low = 200 (\$C8) , Output 1byte-middle = 100 (\$64) , Output 1byte-high =120 (\$78)

Number	Name	Object Function	Description	Group Address	Length	C	R	W	T	U	Data Type	Priority
840	1st Logic	Input 1byte-low			1 byte	C	-	W	-	U	counter pulses (0..255)	Low
841	1st Logic	Input 1byte-middle			1 byte	C	-	W	-	U	counter pulses (0..255)	Low
842	1st Logic	Input 1byte-high			1 byte	C	-	W	-	U	counter pulses (0..255)	Low
848	1st Logic	Output 3byte			3 bytes	C	-	-	T	-	RGB value 3x(0..255)	Low

“3x1byte --> 1x3byte”function: converts three 1byte values to a 3byte value, such as Input 1byte-low = 150 (\$96), Input 1byte-middle = 100 (\$64), Input 1byte-high = 50 (\$32)--> Output 3byte = \$32 64 96



## Description of Communication Object

No.	Object function	Name	Data - Type	Flag	DPT
840	Input ...	{{1st Logic}}	1bit 1byte 2byte 3byte 4byte	C,W,U	1.001 switch 5.010 counter pulses(0..255) 7.001 pulses 232.600 RGB value 3x(0..255) 12.001 counter pulses
The communication object is used to input a value that needs to be converted.					
848	Output ...	{{1st Logic}}	1bit 2bit 1byte 2byte 3byte 4byte	C,T	1.001 switch 2.001 switch control 5.010 counter pulses(0..255) 7.001 pulses 232.600 RGB value 3x(0..255) 12.001 counter pulses
The communication object is used to output the converted value.					

Table 6.8.4 "Logic function\_Format convert" communication object table

### 6.8.5 "Delay function" Communication Object

Number	Name	Object Function	Description	Group Address	Length	C	R	W	T	U	Data Type	Priority
840	1st Logic	Input			1 bit	C	-	W	-	-	switch	Low
848	1st Logic	Output			1 bit	C	-	-	T	-	switch	Low
<b>Input/Output - 1bit[On/Off]</b>												
840	1st Logic	Input			1 byte	C	-	W	-	-	percentage (0..100%)	Low
848	1st Logic	Output			1 byte	C	-	-	T	-	percentage (0..100%)	Low
<b>Input/Output - 1byte[0..100%]</b>												
840	1st Logic	Input			1 byte	C	-	W	-	-	counter pulses (0..255)	Low
848	1st Logic	Output			1 byte	C	-	-	T	-	counter pulses (0..255)	Low
<b>Input/Output - 1byte[0..255%]</b>												
840	1st Logic	Input			2 bytes	C	-	W	-	-	temperature (°C)	Low
848	1st Logic	Output			2 bytes	C	-	-	T	-	temperature (°C)	Low
<b>Input/Output - 2byte[Float]</b>												
840	1st Logic	Input			2 bytes	C	-	W	-	-	pulses	Low
848	1st Logic	Output			2 bytes	C	-	-	T	-	pulses	Low
<b>Input/Output - 2byte[0..65535]</b>												

Fig. 6.8.5 "Delay function" communication object

No.	Object function	Name	Data - Type	Flag	DPT
840	Input	{{1st Logic}}	1bit 1byte 2byte	C,W	1.001 switch 5.001 percentage 5.010 counter pulses 9.001 temperature 7.001 pulses
The communication object is used to input a value that needs to delay.					
848	Output	{{1st Logic}}	1bit 1byte 2byte	C,T	1.001 switch 5.001 percentage 5.010 counter pulses 9.001 temperature 7.001 pulses
The communication object is used to output that needs to delay converted value, delay time is defined by the parameter.					

Table 6.8.5 "Delay function" communication object table

## Description of Communication Object

### 6.8.6 “Staircase lighting” Communication Object

Number	Name	Object Function	Description	Group Address	Length	C	R	W	T	U	Data Type	Priority
840	1st Logic	Trigger value			1 bit	C	-	W	-	-	trigger	Low
841	1st Logic	Light-on duration time			2 bytes	C	-	W	-	-	time (s)	Low
848	1st Logic	Output			1 bit	C	-	-	T	-	switch	Low
848	1st Logic	Output			1 byte	C	-	-	T	-	counter pulses (0.255)	Low

Fig. 6.8.6 “Staircase lighting” communication object

No.	Object function	Name	Data - Type	Flag	DPT
840	Trigger value	{{1st Logic}}	1bit	C,W	1.017 trigger
The communication object is used to receive the value to trigger staircase lighting.					
841	Light-on duration time	{{1st Logic}}	2byte	C,W	7.005 time(s)
The communication object is used to modify the staircase light-on duration time, the modified range is referenced from the range defined by the parameter, take the limit value if exceeded..					
848	Output	{{1st Logic}}	1bit 1byte	C,T	1.001 switch 5.010 counter pulses
The communication object is used to output value 1 when trigger, and send value 2 after duration time. Telegram value is determined by the parameter setting datatype.					

Table 6.8.6 “Staircase lighting” communication object table



01560EN 01 2411